

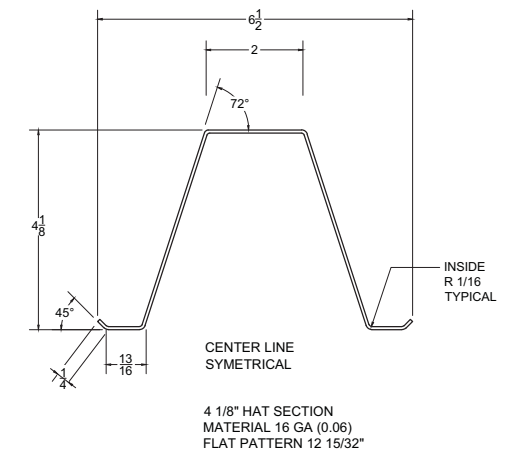

GROSS SECTION PROPERTIES: HAT SECTIONS

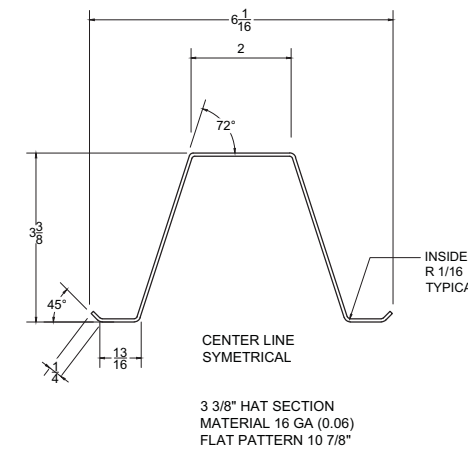
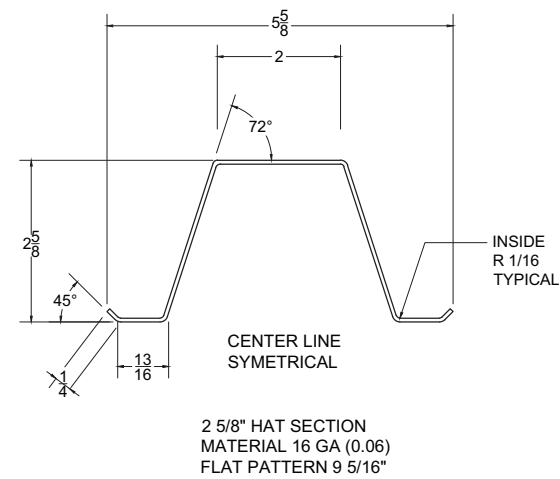
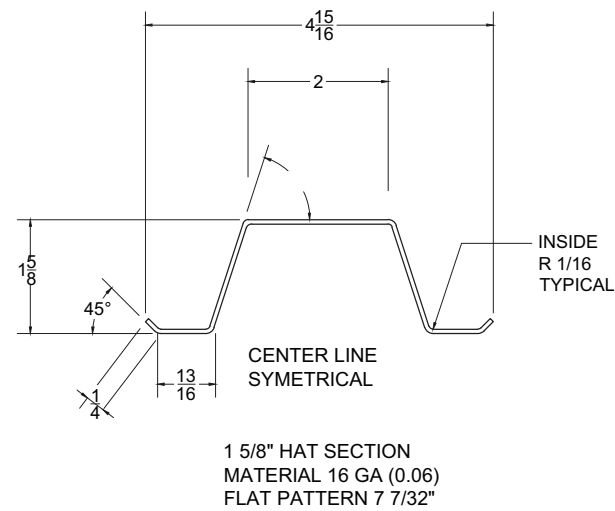
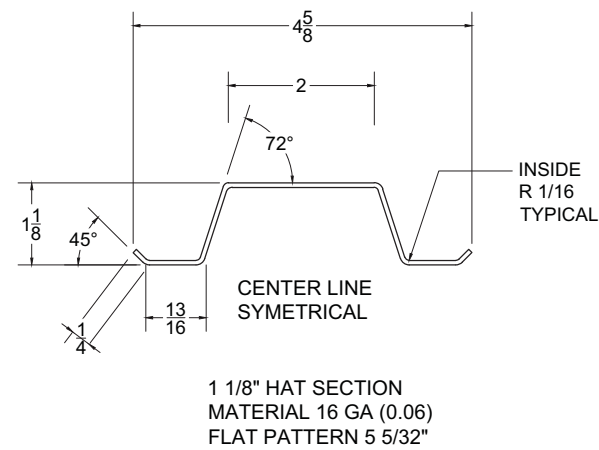

Member					GROSS SECTION PROPERTIES													
					Area A (in ²)	Weight (lb/ft)	Axis X-X			Axis Y-Y			Centroid	Shear Center	Torsional Properties			
							I _x (in ⁴)	S _x TOP (in ³)	S _x BOT (in ³)	r _x (in)	I _y (in ⁴)	S _y LEFT & RIGHT (in ³)	r _y (in)	Y _c (in)	Y _o (in)	J (in ⁴)	C _w (in ⁶)	j (in)
Hat 1 1/8"	1.125	x	4.625	16	0.59972	1.1823	0.1177	0.20832	0.20521	0.4431	0.9697	0.43051	1.2716	.5629	0.7852	0.0050676	0.056445	2.089
Hat 1 5/8"	1.625	x	0.8125	16	0.40836	1.3884	0.1713	0.21027	0.21136	0.6476	0.7811	0.31780	1.3830	.8104	1.2077	0.00043607	0.089857	2.2211
Hat 2 5/8"	2.625	x	0.8125	16	0.52557	1.7869	0.5256	0.39847	0.40142	1.0001	1.2614	0.45313	1.5492	1.3094	1.9762	0.00056123	0.26508	2.8012
Hat 3 3/8"	3.375	x	0.8125	16	0.61666	2.0966	0.9654	0.56969	0.57466	1.2512	1.7347	0.57318	1.6772	1.6805	2.5271	0.00065850	0.47045	3.303
Hat 4 1/8"	4.125	x	1.062	16	0.71895	2.4444	1.628	0.77154	0.80810	1.5049	2.467	0.71453	1.8522	2.0148	3.0191	0.00076773	0.95106	3.80

1. Section properties are calculated in accordance with the 2012 AISI North American Specification for the Design of Cold-Formed Steel Structural Members.
2. Material: 16 Gauge: A653 SS Grade 50 Steel.
3. Strength Increases due to Cold Working has been applied where applicable.
4. Appropriate factors of safety have been applied for Allowable Stress Design (ASD).
5. Strength calculations based on a fully-braced condition.
6. Consult with an engineering professional before using the above design aids.

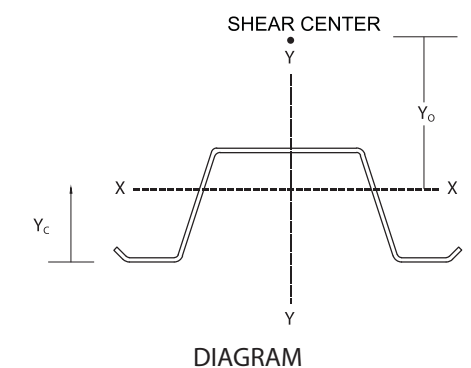



GROSS SECTION PROPERTIES: HAT SECTIONS

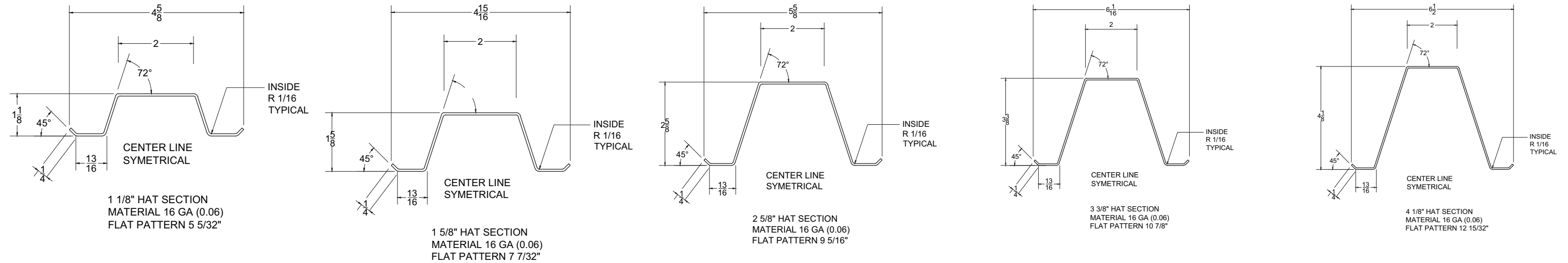

Member					EFFECTIVE SECTION PROPERTIES																				
					Compression		Tension	Shear		Positive Moment (X Axis)				Negative Moment (X Axis)				Positive Moment (Y Axis)				Negative Moment (Y Axis)			
Ga.					A_e (in ²)	P_a (kip)	T_a (kip)	V_{ay} (kip)	V_{ax} (kip)	M_{ax} (kip-in)	I_e (in ⁴)	S_{eTOP} (in ³)	S_{eBOT} (in ³)	M_{ax} (kip-in)	I_x (in ⁴)	S_{eTOP} (in ³)	S_{eBOT} (in ³)	M_{ay} (kip-in)	I_y (in ⁴)	S_{eLEFT} (in ³)	S_{eRIGHT} (in ³)	M_{ay} (kip-in)	I_y (in ⁴)	S_{eLEFT} (in ³)	S_{eRIGHT} (in ³)
Hat 1 1/8"	1.125	x	4.625	16	0.59972	17.715	17.991	2.884	3.399	6.757	0.11774	0.20832	0.20521	6.757	0.11774	0.20832	0.20521	12.890	0.96969	0.43051	0.43051	12.890	0.96969	0.43051	0.43051
Hat 1 5/8"	1.625	x	0.8125	16	0.40633	11.287	12.251	3.063	2.246	6.2554	0.17062	0.20893	0.21108	6.6000	0.17129	0.21027	0.21136	9.5150	0.78108	0.31780	0.31780	9.5150	0.78108	0.31780	0.31780
Hat 2 5/8"	2.625	x	0.8125	16	0.45972	14.047	17.081	5.565	2.614	12.994	0.5224	0.39455	0.40040	13.123	0.5256	0.39847	0.40142	14.721	1.2506	0.45153	0.44700	14.721	1.2506	0.44700	0.45153
Hat 3 3/8"	3.375	x	0.8125	16	0.47979	13.327	18.500	6.413	2.619	16.937	0.9610	0.56569	0.57330	17.881	0.9654	0.56969	0.57446	15.755	1.6419	0.55989	0.52623	15.755	1.6419	0.52623	0.55989
Hat 4 1/8"	4.125	x	1.062	16	0.50363	13.990	21.525	6.413	2.738	20.037	1.6252	0.76944	0.80743	23.083	1.6252	0.77096	0.80571	18.751	2.2129	0.67957	0.62629	18.744	2.2642	0.62603	0.71364

1. Section properties are calculated in accordance with the 2012 AISI North American Specification for the Design of Cold-Formed Steel Structural Members.
2. Material: 16 Gauge: A653 SS Grade 50 Steel.
3. Strength Increases due to Cold Working has been applied where applicable.
4. Appropriate factors of safety have been applied for Allowable Stress Design (ASD).
5. Strength calculations based on a fully-braced condition.
6. Consult with an engineering professional before using the above design aids.