

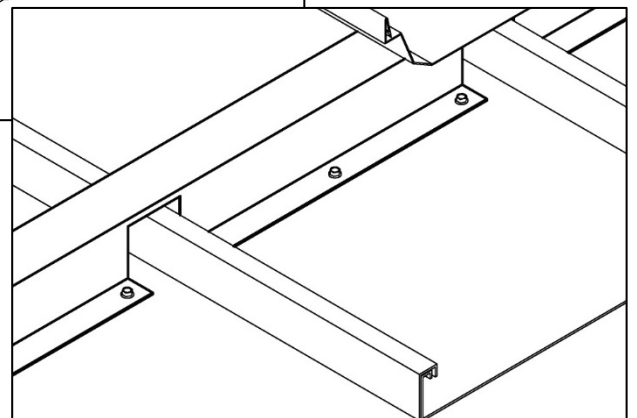

Design & Installation Manual

2020 EDITION

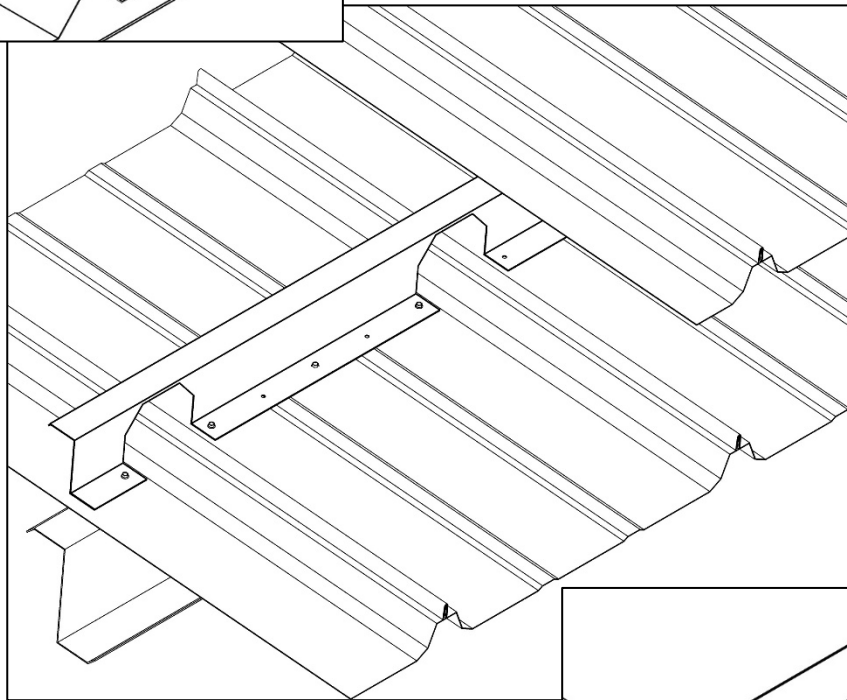
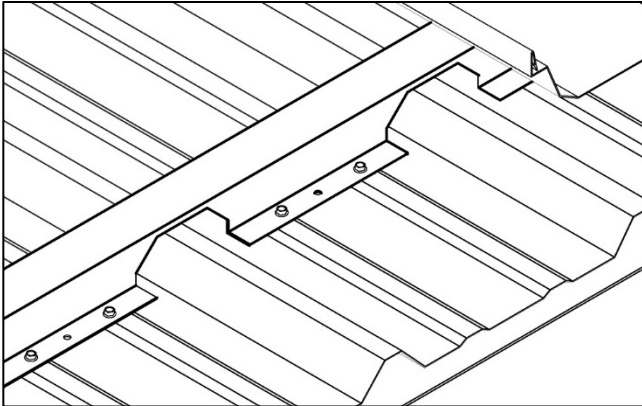

The Most Recognized and Tested
Metal-over-Metal Retrofit
Solutions



Design and Installation Manual

To Metal-over-Metal

Retrofit Roof Systems

Version 5.00

Dated: July 15, 2019

© Roof Hugger, LLC 2019

Corporate Office
P.O. Box 1027
Odessa, FL 33556

142 Whitaker Road
Lutz, FL 33549
(800) 771-1711
Fax: (877) 202-2254
Email: sales@roofhugger.com

www.roofhugger.com

The information contained within this manual is intended to serve as a guide to illustrate retrofit metal re-roofing methods as practiced by Roof Hugger, LLC. It is believed to be true and accurate at the time of printing. Certain specifications may be subject to change and some components may vary slightly in appearance from those pictured. Depending on specific project requirements, adaptation, modification or production of custom components may be necessary. All references to the new metal roof system, being installed over the Roof Hugger sub-framing, are not intended to replace those as recommended by any metal roof manufacturer. For specific metal roof system flashing, trim and fastening requirements, refer to your metal roof manufacturer's standard details, specifications and practices. If you have questions relative to a application or condition, please contact Roof Hugger, LLC to ensure you have the most current information available on our sub-framing systems and components.



Table of Contents

Roof Design Basics	4-6	Integral Corner and/or Zone Framing	32-33
Roof Hugger Applications	7-8	Hat Grid Corner and/or Zone Framing	34-35
Energy Efficient Reroofing		Typical Construction Details Table of Contents	36-38
Insulated Systems	9-10	Standard Construction Details	39-106
Ventilated Systems	10-11	Insulated Assembly Details and Thermal Resistance Values	107-126
Roof Hugger Testing and Approvals	12-16	User Notes Page	127
Product Guide Specifications	17-24		
Hugger System's Installation			
Receiving Materials	25		
Handling	25		
Installation Basics	25		
Existing Flashing and Trim	25		
Bridging Requirements	25		
Out of Module Roof Panels	25-26		
Installing Over Existing Skylights	26		
Existing Standing Seam Roofs with Thermal Blocks and Stand-off Clips	26		
Existing Fasteners	27		
Fastener Patterns	27		
Installing Over Corrugated Panels	27		
Midspan Attachment	28		
Existing Purlin Strengthening	27-29		
Grid Framing	29		
Panel Fixity	29		
Fastener Types	30		
Step-by-Step Installation	31-33		

*Note: Refer to Roof Hugger's website for the most current up-to-date information including our standard construction details.
Visit us at: www.roofhugger.com*

THE A B C'S & D'S OF RETROFIT ROOF DESIGN

In 2004 most states and municipalities adopted the new "International Building Code" (IBC). Within the current 2015 IBC is ASCE 7-10. This is where the calculation for wind and snow loads is dictated. ASCE 7-10 divides the roof into three zones: The "Field" or center of the roof, the "Edge or Perimeter Zone" and the "Corner" zone of the roof. The loads for each "Zone" are calculated separately. A newer version of the code has been released and is slowly beginning to be adopted around the country. This version is 2018 IBC and ASCE 7-16. This version of the code divides the roof into even more areas as demonstrated below. Coastal loads are also significantly higher than previous codes.

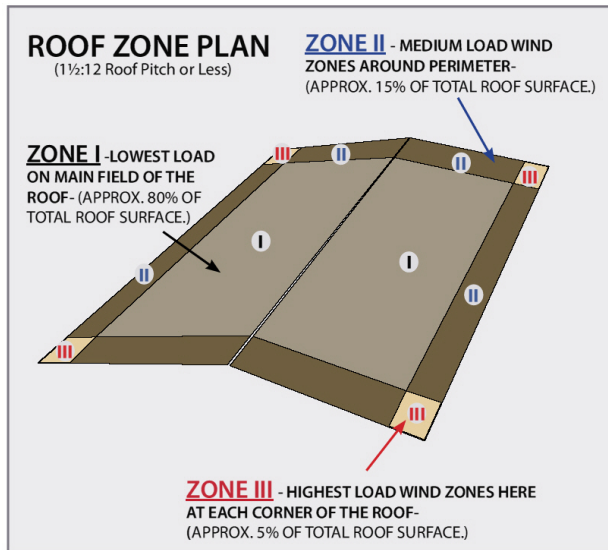

The new roof must withstand the full forces calculated for each of these "Zones". Because of the new higher wind speeds and snow loads mandated by the current codes, older buildings frequently do not meet the current code requirements and must be upgraded with additional framing and/or stronger roof panels.

Since no two buildings are exactly alike, the size and shape of these "Zones" varies from building to building and depends on several factors. Each building must be considered individually and engineered based on existing conditions and proposed changes. The basic steps in the process are as follows on the next page:

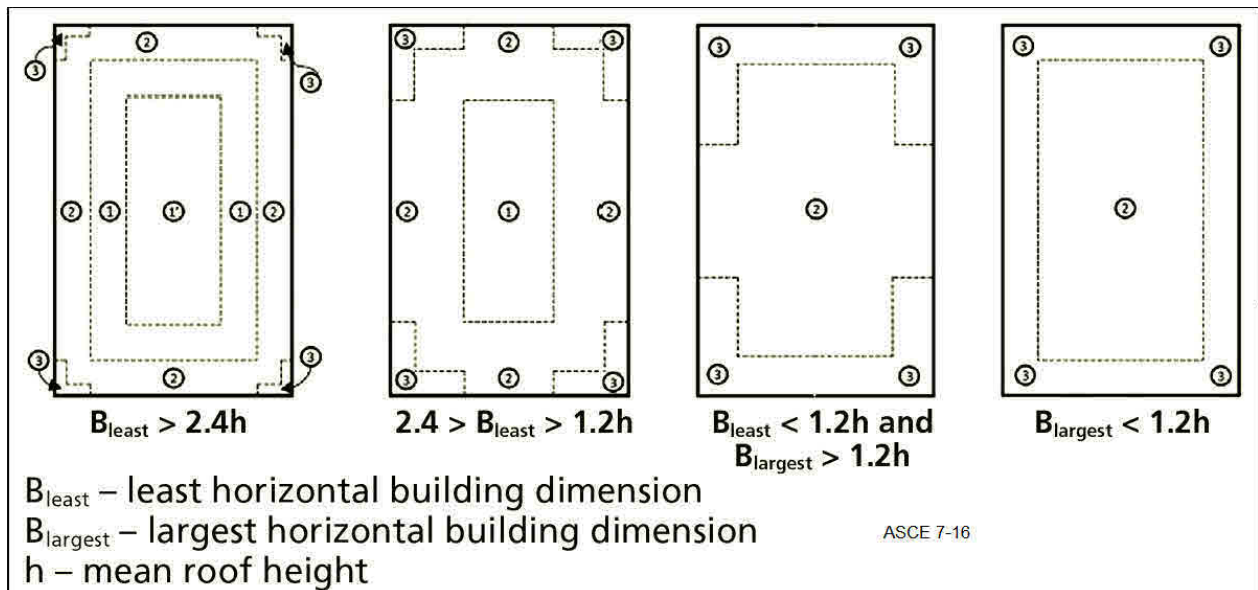

The basic steps are:

- **STEP A:** Collect the basic information needed:
 - Building Address to:
 - Determine current code, wind speed, snow load and exposure category.
 - Width and Length of Roof Area
 - Mean Roof Height
 - Roof Pitch
 - Existing Purlin Spacing
 - Note Parapets 36" or Higher
 - Occupancy Category: I, II, III, or IV
 - Identify the existing panel profile
 - If existing roof is standing seam, determine if it is mounted on low or high clips.
- **STEP B:** There are two choices here, you or your customer can hire an engineer to calculate the loads and design the sub-framing system, or you can obtain a quick estimate of the design pressures from the NRCA Website at www.roofwinddesigner.com. This information is preliminary in nature and must eventually be reviewed by an engineer, but it will give you a very good idea of the loads. Under IBC 2010, if we assume a 100x150x20, 1:12, 100 mph, exposure "B", occupancy category "II", this program will calculate the loads by zone. It will then produce a printout with assumptions and details outlining the preliminary loads: Zone 1 (roof area field): 18.0 psf, Zone 2 (roof area perimeter): 30.2 psf, and Zone 3 (roof area corners): 45.4 psf. (This print out is also a nice sales tool) The **corner zone/edge distance** will also be calculated and listed and in this case, it is 8'-0". This means edge and corner loads must be met 8' in from the eave and rake areas.
- **STEP C:** If the existing purlin spacing is 5' (typical in older buildings) you would compare the manufacturers published capacity for the new panel on 5' purlin spacing to the values provided by an engineer or estimated by the NRCA site. (Check the panel values to make sure they have not been increased by 33% for wind loads). If we assume the new roof is to be a 24" o.c trapezoidal standing seam with a useable panel capacity of 42 psf on 5' purlin spacing*. The panel can meet the estimated loads in Zone 1 (field) and Zone 2 (perimeter) but not Zone 3 (corner). Therefore, additional framing must be added to reduce the purlin spacing in the corners. The other option is to consider a narrower rib spacing or heavier gauge panel that has a capacity in excess of 45.4 psf on 5' purlin spacing in which case no additional framing is needed.
**Panel capacity on Roof Huggers may vary from manufacturers testing, verify panel capacity with Roof Hugger.*
- **STEP D:** If additional framing is needed to reduce the purlin spacing, it must be determined what that framing consists of. We have several options here: Framing could be additional purlins installed from under the old roof (often very difficult if not impossible). Grid systems made from "C's", "Z's", Hats or a combination of all can be added on top of the existing roof or we could use Pre-Notched "Z's" with fitted Sub-Rafters to achieve the correct panel attachment spacing at the mandated code pressures. This corner framing must be the same height as the sub-framing system on the balance of the roof to keep the entire system in the same plain.

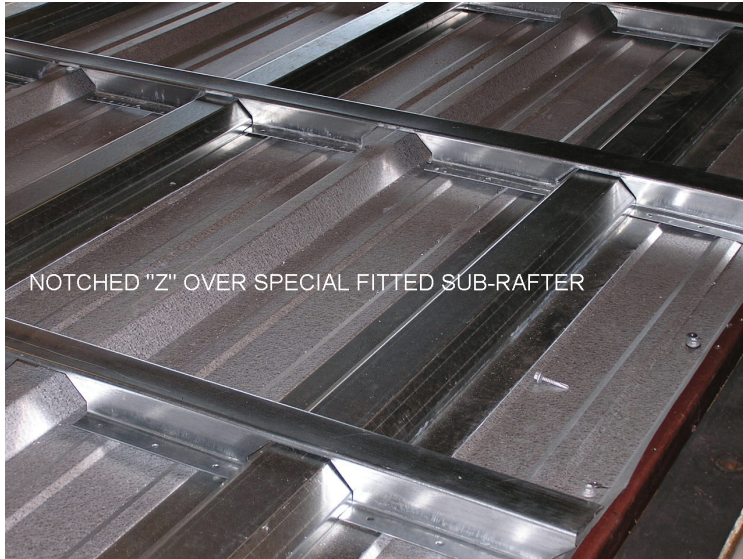

Seem a bit more complicated than it used to be? Well, it is, and just because the existing roof is 26 ga. "R" panel on 5' purlins doesn't mean a new 26 ga. "R" panel roof on 5' purlins will meet the current code. You have to go through the above process to find it out. After a couple of times you'll get the hang of this process, it's really not too bad.

If you need assistance with the above process please feel free to call Roof Hugger, LLC at 800-771-1711 or fill out an online quote request from our website www.roofhugger.com and email to us.

Hugger Applications

Initially developed for re-roofing existing metal buildings, Roof Hugger products have been used very effectively in installations with conventionally framed roof construction having wood rafters and purlins, plywood decking, bar joist with metal decking and rigid insulation as well as other structural framing systems finished with a metal roofing top layer. For new construction applications where an air-space cavity is necessary between a new metal roof and a sub-deck for energy efficient and solar thermal systems, Huggers can be designed to accommodate the cavity depth and air flow required.

Below are the most common Hugger profiles for adaptation to an existing metal roof. If your project includes a profile not seen here, all is needed are the physical dimensions of the existing roof.

Roof Hugger Profiles		
Existing Roof Panel with Required Dimensions		Compatible Hugger
12" O.C. Ribbed Panel (Our Model "C")		
6"-10" O.C Ribbed Panel		
7.2" Industrial Rib		
Trapezoidal SSR Without Stand-off Clips 12", 18" and 24" (24" is Our Model "D")		
Trapezoidal SSR With Stand-off Clips 12", 18" and 24" (24" is Our Model "T")		

Energy Efficient Re-roofing

It is important to understand that when retrofitting over existing sloped metal or solid deck roof systems, the Roof Hugger sub-purlin will create an air-space/cavity between the old roof and underside of the new roof. This air-space presents several options to the contractor and building owner. Simply stated, the space can be used to improve the building inhabitant's comfort and environment as well as provide significant energy benefits through alternative energy resources. Consider the following before finalizing your re-roofing plans.

Insulated Systems



Unfaced Fiberglass



Rigid Board Insulation

Metal building construction over the years has historically used low R-value insulation between the existing purlins and metal roofing. Because of this, these buildings may be inefficient in reducing heat gain through the roof assembly in the

summer as well as heat loss during the winter months. Adding insulation between the old and new roofs is a cost-effective measure to decrease the building's energy consumption while paving the way to pay for itself in a relative short time frame.

As shown in the photos above, fiberglass insulation is predominantly used in a "Metal-over-Metal assembly, but to gain even more

thermal resistance in the minimal space, rigid board (polyiso) can be easily incorporated. With fiberglass, unfaced without a vapor barrier is typically used, but in some cases for projects located in the far northern climates, a laminated vapor barrier has been used.

Please note that the thickness of the insulation may vary dependent on code requirements, as may be required with the ASHRAE 90.1 Model Energy Code or IECC 2015. If the code does require a minimum R-Value, the depth of the Huggers can easily be increased to permit thicker insulation without adding major cost to the project.

Actual project case studies have illustrated up to 25% reduction in energy fuel source consumption for heated and air-conditioned buildings.

In this edition of the Design & Installation Manual, there are 14 additional details on pages 107-120 that illustrate the actual thermal resistance values of various Roof Hugger metal-over-metal retrofit assemblies using fiberglass insulation. In addition, on pages 121-126, there are 6 details that provide thermal resistance values including single, double and triple layer rigid board insulation in the retrofit assembly.

The Tables on the next page also provide thermal resistance values (R-Value) for the type and thicknesses commonly found in existing metal building roofs. These can be used to determine the overall thermal resistance of the new retrofitted assembly if the existing building roof was in fact insulation and if you plan to add insulation in the new construction.

Energy Efficient Re-roofing

<i>Vinyl-Faced Fiberglass insulation typically found in existing metal buildings</i>	
Thickness	R-Value
1½"	5.0
2"	7.0
3"	10.0
4"	13.0
6"	19.0

<i>Rigid Board polyisocyanurate insulation (Dow™ Thermax or equal)</i>	
Thickness	R-Value
1"	6.5
2"	13.0
3"	19.0
4"	25.2

Notes pertaining to tables above:

1. When adding insulation to comply with locally adopted Energy Codes, the existing insulation should be included in the overall R-Value.
2. When using rigid board insulation, it has been recommended that the air-space void between the existing roof panel's ribs to be filled with unfaced low-density fiberglass to prevent moisture from infiltration of warmer air from the building
3. Polystyrene is not an acceptable rigid insulation board for Metal-over-Metal assembly's due to fire class ratings and it may require a minimum 22-gauge deck/existing roof.
4. If "Continuous Insulation" (CI) is required by the building code, at least one-layer of minimum thickness rigid insulation must be installed over the Huggers with joints taped, therefore requiring the new metal roof system to use a roof clip with a bearing plate. "CI" cannot be accomplished with screw-down/thru-fastened metal roofs or using fiberglass insulation

Ventilated Systems

If the building that is being retrofitted is not thermally controlled, then adding insulation may or may not be of benefit. At the very least, Roof Hugger recommends the airspace between the old and underside of the new metal roof should be ventilated. This is easily accomplished using economical ventilation products at the low eave and high point (ridge, high eave, etc.) of the roof. When ventilated, the air in the cavity becomes a radiant barrier that reduces heat gain/loss. This roofing technology is known throughout the metal roofing industry as Above Sheathing Ventilation or "ASV" and is illustrated on the next page.

Please note that this assembly is very effective for buildings that are temperature controlled. Case studies for these systems have illustrated nearly 21% decrease in energy consumption. In warmer climates, this system is very effective in improving the building's interior environment. This is especially true for buildings that have working occupants such as livestock confinement, manufacturing and warehousing.

Ventilated and Insulated Systems

It is possible to incorporate both new insulation and ventilation in the cavity between the old and new roofs as shown in the illustration on the next page. In fact, building envelope industry experts claim this is the best of both worlds. To accomplish this, the thickness of insulation is determined and the Roof Hugger sub-purlins are then manufactured approximately two inches taller to permit air-flow above the insulation. Another technique

Energy Efficient Re-roofing

can be used by installing a vent strip atop the Huggers for systems using new standing seam metal roofs with tall stand-off type clips.

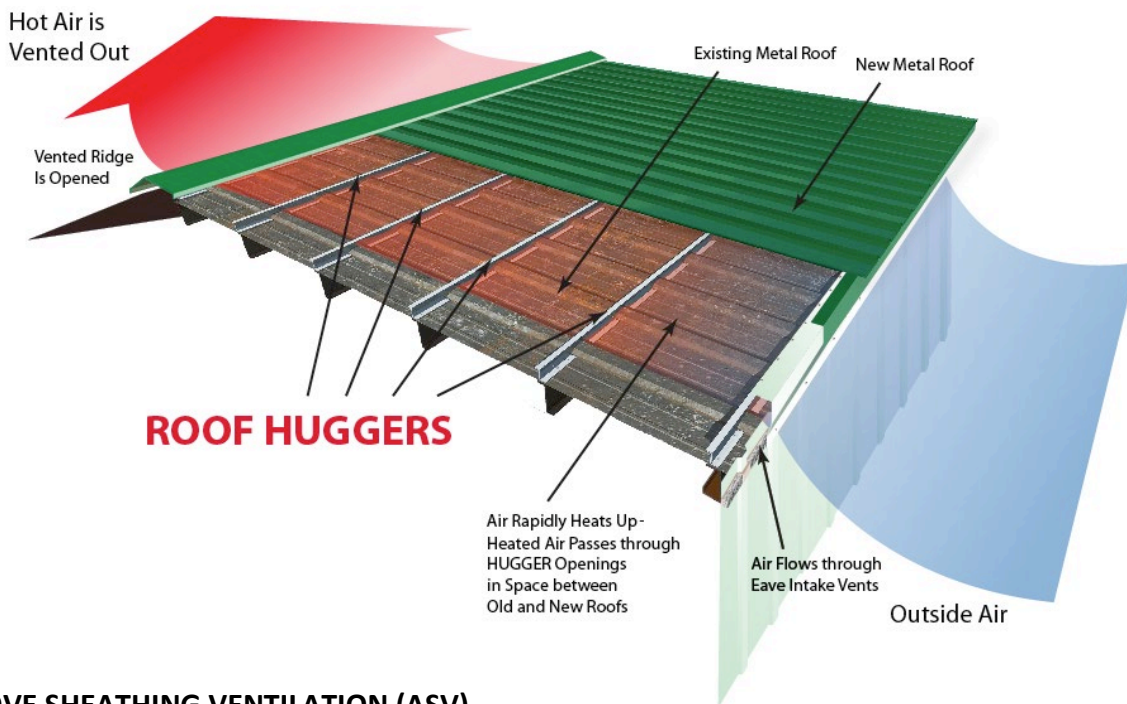

ABOVE SHEATHING VENTILATION (ASV)

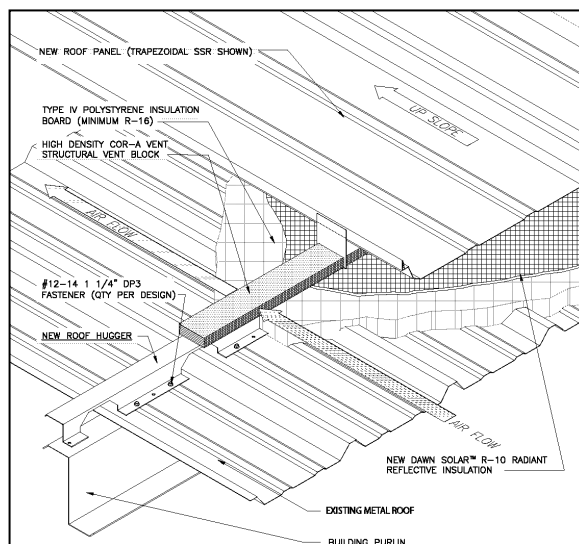

VENTILATED ASSEMBLY WITH INSULATION

Hugger Applications

<p>Vertical Rib SSR 12", 16", 18" and 24"</p>		
<p>Over Corrugated Roofs 2.5", 2.67", 2.75" and 4.2"</p>	<p><i>For Information, Refer to our Corru-Fit™ Design Guide</i></p>	

Because of the manner Huggers are manufactured, they can match virtually any known metal roof profile. As you can see from the profiles on the preceding page, the most common are ribbed panels with varying rib spacing and standing seam systems (SSR) with varying seam spacing.

For Corrugated type panels, our Corru-Fit™ sub-framing product as shown above is a special system that takes the issues related to these roof's inconsistent corrugation spacing. For more information on this product, please refer to Corru-Fit's Design Guide on our website.

Since 1991, we have been building a library of current and obsolete metal panels from metal roofing manufacturers. The list includes many metal roof systems that are obsolete or no longer manufactured plus new ones that have been added to the market in recent years. This extensive library allows us to verify existing roof profiles that need to be identified dimensionally. Even to this day we occasionally discover a roof profile that we did not know existed. With Roof Hugger's custom fabrication capability, it is typically not a problem to accommodate these.

Today, Roof Hugger has become the re-roofing sub-purlin system of choice by Private and Military Design Professionals, Roof Consultants, Contractors and Facility Managers throughout the Nation.

This Design and Installation Guide is intended to provide the User with an expanded view into the world of Metal-over-Metal roof replacement over an existing sloped roof without removing it. If you should have any questions that this manual cannot answer please feel free to call us at 1-800-771-1711.

Testing and Approvals

ASTM E-1592 TESTING OVER 16 GA HUGGERS

McElroy Metal & Architectural Building Components 24 GA x 18" JSM200 DL

- Test A – Hugger and purlin spacing @ 5'-0"
- Test B – Purlins @ 5'-0", Sub-rafters @ 24" and Huggers @ 2'-6" over 26 GA "PBR"
- Test C – Purlins @ 5'-0", Sub-rafters @ 12" and Huggers @ 1'-3" over 26 GA "PBR"

Custom-Bilt Metals 24 GA x 16" CB-2000

- Test A – Hugger and purlin spacing @ 5'-0"
- Test B – Hugger and purlin spacing @ 1'-0"
- Test C – Purlins @ 5'-0", Sub-rafters @ 24" and Huggers @ 2'-6" over 26 GA "PBR"

Englert, Inc. 24 GA x 16" Series S-2500

- Test A – Hugger and purlin spacing @ 5'-0"
- Test B - Hugger and purlin spacing @ 2'-6"

Englert, Inc. 0.040" x 16" Series S-2500

- Test A – Hugger and purlin spacing @ 5'-0"
- Test B - Hugger and purlin spacing @ 2'-6"

Firestone Building Products 24 GA x 18" UC-6

- Test A – Hugger and purlin spacing @ 5'-0"
- Test B – Hugger and purlin spacing @ 1'-0"
- Test C – Purlins @ 5'-0", Sub-rafters @ 24" and Huggers @ 2'-6" over 26 GA "PBR"

Firestone Building Products 22 GA x 18" UC-6

- Test A – Hugger and purlin spacing @ 5'-0"
- Test B – Hugger and purlin spacing @ 1'-0"
- Test C – Purlins @ 5'-0", Sub-rafters @ 24" and Huggers @ 2'-6" over 26 GA "PBR"

MBCI 24 GA 16" SuperLok™

- Test A – Hugger and purlin spacing @ 5'-0"
- Test B - Purlins @ 5'-0", Sub-rafters @ 1'-0" and Huggers @ 2'-6" over 26 GA "PBR"
- Test C – Purlins @ 5'-0", Sub-rafters @ 24" and Huggers @ 2'-6" over 26 GA "PBR"

MBCI 26-22 GA "PBR over 26 GA "PBR"

- Test 06B – Hugger and purlin spacing @ 5'-0" fastened at 12"-12"-12"
- Test 06C - Hugger and purlin spacing @ 5'-0" fastened 7"-5"-7"-5"
- Test 06D – Purlins @ 5'-0", Sub-rafters @ 24" and Huggers @ 2'-6" fastened 7"-5"-7"-5"
- Test 06E – Purlins @ 5'-0", Sub-rafters @ 12" and Huggers @ 2'-6", fastened 7"-5"-7"-5"

Notes:

- All Testing per ASTM E-1592-01 - TAS 125-03
- Refer to Installation Section, pages 27 & 28 for Sub-rafter/Hugger details of construction
- Existing purlins spaced @ 5'-0" for all tests unless noted otherwise
- All testing conducted by third-party independent test laboratories.

AISI GRAVITY AND WIND UPLIFT LOAD BASE TESTING *(Refer to Special Note no. 5 at end of this testing information for disclaimer)*

Standard Model "C" 16 GA Hugger with ¼" bridge above panel rib notch for 12" o.c. "R" Panel – Refer to Detail HL-01-G on page 63

Purlin Depth and Gauge	Existing Purlin Span FT	Wind Uplift % Increase	Gravity Load % Increase
8"X16	25'-0"	85%	42%
8"X14		50%	37%
8"X12		0.2%	25%

Special 16 GA Hugger with 1" bridge above panel rib notch for 12" o.c. "R" Panel – Refer to details HL-02-/16-14 and HL-03-R/12 on pages 59 and 60.

Table on Next Page

Testing and Approvals

Purlin Depth and Gauge	Existing Purlin Span FT	Wind Uplift % Increase	Gravity Load % Increase
8"X16	25'-0"	94%	79%
8"X14		65%	66%
8"X12		22%	37%

AISI Testing Notes:

1. Dade County Laboratory Certification: No. 05-1122.13
2. All roof assemblies were tested with LGSI standard Purlins with 26 GA roof panels attached to top flange
3. All roof assemblies were tested with bottom flanges completely unbraced
4. All tests were conducted in compliance with AISI TS-8-02 Base Test Method for Purlins supporting a standing seam roof.
5. **Special Note:** *It is the responsibility of the owner or general contractor to hire a design professional to do a thorough investigation of the existing metal building system to ensure that the design is adequate for the additional loading. Our testing has confirmed that the additional loads of the Roof Hugger System were more than compensated by the existing system for purlins depths up to 8-inch. However, existing purlin laps where combined shear and bending occurs were not evaluated due to the limitations of the AISI Base Test Method. Our engineering design only addresses the performance of the Roof Hugger System, its attachment to existing purlins, and the interaction of the new metal roof system.*

Roof Hugger Sub-Purlin Rollover Testing

Testing on various height Sub-Purlins and various profiles to determine rollover limitations to control panel drag loads.

Factory Mutual Standard 4471 Approval

Approval No. 3033681, Architectural Building Components 15-7/8" wide 24 Ga. JSM 238T as provided by McElroy Metal of Bossier City, LA. with various clips over several Roof Hugger profiles @ 5'-0" O.C. met Classes 1-75, 1-120 and 1-195, Visit www.mcelroymetal.com for details.

APPROVALS WITH NEW THRU-FASTENED/SCREW-DOWN METAL ROOFING – 2015 Master 9352-R4

Product Approval – FL 9352.2

This product approval is for buildings with an existing 12" O.C. "PBR" panel 26 Ga. or heavier through-fastened roof with a new roof panel 12" O.C. "PBR" 26 Ga. as provided by MBCI of Houston, TX (Panels with equivalent properties are acceptable). The Product Approval includes a table indicating several retrofit framing options and sub-frame spacing's. Each assembly having varying capacities from -40 PSF to -140 PSF at the noted deflection levels.

Product Approval – FL 9352.3

This product approval is for buildings with an existing 12" O.C. "PBR" panel 26 Ga. or heavier through-fastened roof with a new roof panel 12" O.C. "PBR" 24 Ga. as provided by MBCI of Houston, TX (Panels with equivalent properties are acceptable). The Product Approval includes a table indicating several retrofit framing options and sub-frame spacing's. Each assembly having varying capacities from -40 PSF to -145 PSF at the noted deflection levels.

Product Approval – FL 9352.4

This product approval is for buildings with an existing 12" O.C. "PBR" panel 26 Ga. or heavier through-fastened roof with a new roof panel 12" O.C. "PBR" 22 Ga. as provided by MBCI of Houston, TX (Panels with equivalent properties

Testing and Approvals

are acceptable). The Product Approval includes a table indicating several retrofit framing options and sub-frame spacing's. Each assembly having varying capacities from -48.1 PSF to -124.9 PSF at the noted deflection levels.

APPROVALS WITH NEW STANDING SEAM METAL ROOFING

Product Approval - FL 9352.1

This product approval is for buildings with an existing 12" O.C. "PBR" panel 26 Ga. Or heavier through-fastened roof with a new 238-T 18" O.C., 22 Ga., vertical rib standing seam roof as provided by McElroy Metals of Bossier City, LA. The Product approval includes a table indicating several retrofit framing options and sub-frame spacing's. Each assembly having varying capacities from -55 PSF to -125 PSF at differing sub-purlin spacing's.

Product Approval - FL 9352.5

This product approval is for buildings with an existing 12" O.C. "PBR" panel 26 GA. or heavier through-fastened roof with a new 16" SuperLok, vertical rib standing seam roof as provided by MBCI of Houston, TX. The Product Approval includes a table indicating several retrofit framing options and sub-frame spacing's. Each assembly having varying capacities from -47.5 PSF to -80 PSF at differing sub-purlin spacing's.

Product Approval - FL 17626

This product approval is for buildings with an existing 12" O.C. "PBR" panel 26 GA. or heavier through-fastened roof with a new 24 GA 18" x

2" vertical rib 238-T standing seam roof as provided by McElroy of Bossier City, LA. The Product Approval includes a table indicating several retrofit framing options and sub-frame spacing's. Each assembly having varying capacities from -123.5 PSF to -161 PSF at differing sub-purlin spacing's over structural steel decking.

NOTES FOR LISTED APPROVALS:

All Existing Purlin Spacing = 5'-0" O.C. max

All New PBR Panel is 36" wide with 1¼" tall rib

- 26 GA = 80 KSI
- 24 GA = 50 KSI

Hats = Special Hugger Sub-rafters

ROOF HUGGER COMPOSITION & MATERIALS

Roof Hugger Sub-purlin System's base materials is G-90 galvanized finished steel sheet per ASTM A-446 or A-570 with 50 ksi minimum yield strength. Material thickness is available to meet design loads in 16 and 14 gauges.

PROFILES AND CHARACTERISTICS

The profile used for Florida Product Approval is the Roof Hugger standard roll-formed Type "C" model, manufactured to accommodate existing ribbed metal roofing with maximum 1½" high major ribs spaced at 12" on center. In addition, other standard types include Hugger profiles manufactured to accommodate the following popular panel types:

12" to 24" O.C. Trapezoidal Rib SSR

12" to 20" O.C. Vertical Rib SSR

6"-10" O.C. Ribbed Panel

2.5", 2.67", 2.75" and 4.2" Corrugated

7.2" Industrial Rib

Testing and Approvals

All Roof Hugger Sub-purlins are zee shaped steel members with 1.06" minimum bottom flange and 2.0" minimum top flange plus a .25" minimum lip. The web depth varies based on the existing panel profile dimension or desired insulation thickness. The die-stamped web window that allows nesting over the existing roof system ribs also may vary per job application and requirements. All are shipped in 10'-0" lengths plus or minus to fit existing panel rib or seam modules.

Roof Hugger Sub-purlins are intended to attach directly above and to the existing building secondary support members. These members are most commonly zee shaped purlins, steel bar joist or other types of framing. When these members exceed the maximum spacing as dictated by the new roof panel system, the Roof Hugger Sub-purlins must employ "sub-rafter" hats and/or "struts" that span over the existing purlin. By doing this, the Roof Hugger Sub-Purlins can be installed at mid-span conditions (between existing purlins).

OTHER ROOF HUGGER TESTING

Many other metal roof panel manufacturers have tested their systems in accordance with ASTM E-1592 Standard Test Method for Structural Performance of Metal Roof and Siding Systems by Uniform Static Air Pressure Difference. Please visit our website for the most current reports on these tests.

BUILDING CODES

Current data on building code requirements and product compliance may be obtained from ROOF HUGGER technical support specialists. Installation must comply with the requirements of Chapters 15, 16 and 22 of the FBC 2016 Code.

FLORIDA PRODUCT APPROVAL LIMITATIONS AND CONDITIONS OF USE FOR NON-HIGH VELOCITY HURRICANE ZONES (NON-HVHZ)

DESIGN PROCEDURE: Based on the dimensions of the structure, appropriate loads are determined using Chapter 16 of the Florida Building Code (FBC) for roof cladding wind loads. These component wind loads for roof cladding are compared to the allowable negative/positive pressures listed in the load table. The design professional shall select the appropriate erection details to reference in his/her drawings for proper fastener attachment to the structure and analyze the panel fasteners for pullout and pullover. Support framing must be in compliance with FBC Chapter 22 for steel and Chapter 16 for structural loading.

OTHER CONDITIONS:

Minimum Roof Slope Limitation: ½:12
Existing Purlin Spacing: Maximum 5'-0" O.C. designed by a Florida P.E.
Existing Roof Panel: Based on 26 GA R-Panel or "PBR", 80 KSI with 12" O.C. x 1¼" tall ribs and 36" coverage
Substrate Attachment: Designed by a Florida P.E.
Fire Barrier: Class B fire exposure rating in accordance with FBC Section 1505.3
Underlayment: Vinyl or reflective foil faced fiberglass batt insulations that have a flame spread rating of no more than 25 and a smoke development rating of not more than 450 assumed under the existing roof
Shear Diaphragm: Shear diaphragm values were outside the scope of the Approval reports

MAXIMUM ROOF COMPONENT UPLIFT PRESSURES:

Cont'd Next Page

Testing and Approvals

Product Approval – FL 9352.1 (238T Panel System over Roof Huggers)

238T Panel Clip	16 GA Fixed	24 GA Continuous Clip	22 GA Continuous Clip
Maximum Design Pressure	-55.0 PSF	-100.0 PSF	-125.0 PSF
Roof Hugger	Standard Model "C"	Standard Model "C"	Gusseted Model "C"
Roof Hugger Spacing	5'-0" O.C.	5'-0" O.C.	5'-0" O.C.
Roof Hugger # of Fasteners	(2) per Foot	(2) per Foot	(4) per Foot

*Design Pressure includes a Safety Factor = 2.0

Product Approval – FL 9352.2 (PBR Panel System over Roof Huggers)

System No.	Maximum Allowable Pressures (Psf)			
	Allowable Test Value	Controlled by Panel Deflections		
		L/120	L/180	L/240
1	40.0	40.0	40.0	38.8
2	65.0	65.0	45.7	33.8
3	110.0	110.0	110.0	110.0
4	140.0	140.0	140.0	116.7

Product Approval - FL 9352.3 (PBR Panel System over Roof Huggers)

System No.	Maximum Allowable Pressures (Psf)			
	Allowable Test Value	Controlled by Panel Deflections		
		L/120	L/180	L/240
1	35.0	35.0	31.44	26.42
2	60.0	60.0	60.00	58.14
3	116.0	116.0	111.77	85.14
4	145.0	145.0	120.41	92.24

Product Approval – FL 9352.4 (PBR Panel System over Roof Huggers)

Maximum Allowable Pressures (PSF)				
Roof System	Allowable Design Pressure (PSF)	Based on Panel Deflections		
		L/120	L/180	L/240
1	48.1	48.1	46.0	35.2
2	88.5	58.1	40.6	32.7
3	124.9	124.9	124.9	124.9

*Design Pressure includes a Safety Factor = 2.0

Product Approval – FL 9352.5

(Super Lok 16-24 Panel System over Roof Huggers)

Negative Design Loads (PSF)		
Roof Hugger spacing	E-1592 load	Allowable Design load
2.50 FT	160.0	80.0
5.00 FT	95.0	47.5

Product Approval - FL 17626 (238T Panel System over Roof Huggers)

Maximum Design Pressure	-125.3 PSF	-161.0 PSF
Roof Hugger Spacing	4'-0" O.C.	2'-0" O.C.
Roof Hugger # of Fasteners	(3) #14-13 per 36"	(3) #14-13 per 16"

Design Pressure includes a Safety Factor = 2.0

INSTALLATION REQUIREMENTS:

Please contact Roof Hugger to obtain specific FL Product Approval erection details.

Product Guide Specifications

PLEASE NOTE: These specifications are available in a MS Word document that is editable to suit your project. Refer to the “Editable Design Specifications 13145” file included on our complimentary Flash Drive, or you may download from our website at www.roofhugger.com under “Helpful Documents”.

SECTION 13 34 21 - STRUCTURAL RETROFIT ROOF SUB-FRAMING SYSTEM

PART 1 - GENERAL

1.1 DESCRIPTION

- A. The structural retrofit roof sub-framing system will provide support for a new metal roofing system constructed over the existing building roof. It shall be engineered in accordance with
- B. the specified code and design loading and shall transfer positive acting loads at each attachment location into an existing structural member.
- C. Furnish labor, material, tools, equipment and services for the fabrication of retrofit roof sub-framing as indicated, in accordance with provisions of the Contract Documents.
- D. Completely coordinate work with of other trades.
- E. Although such work is not specifically indicated, the contractor/installer shall coordinate with the metal roof system supplier to furnish and install supplementary or miscellaneous items, appurtenances and devices incidental to or necessary for a sound, secure and complete installation.
- F. Reference Division 1 for General Requirements

1.2 RELATED WORK

- A. Section 05 40 00 - Cold-Formed Metal Framing.
- B. Section 07 22 00 - Roof and Deck Insulation.
- C. Section 07 40 00 - Metal Roofing.
- D. Section 07 72 00 - Roof Accessories.
- E. Section 08 60 00 – Skylights.
- F. Section 13 34 19 - Pre-Engineered Structures (Metal Building Systems).
- G. Section 22 05 00 - Basic Mechanical Materials and Methods for Plumbing Piping.
- H. Section 23 31 00 Ventilation Ducts.
- I. Section 26 05 00 – Electrical Demolition and Modifications.

Product Guide Specifications

1.3 QUALITY ASSURANCE AND REFERENCES

A. ASTM International

1. ASTM A 653/A 653M - Standard Specification for Steel Sheet, Zinc-Coated (Galvanized) or Zinc-Iron Alloy-Coated (Galvannealed) by the Hot-Dip Process.
2. ASTM A 1011/A 1011M - Standard Specification for Steel, Sheet and Strip, Hot-Rolled, Carbon, Structural, High-Strength Low-Alloy and High-Strength Low-Alloy with Improved Formability, and Ultra-High Strength.
3. ASTM E 1592 - Standard Test Method for Structural Performance of Sheet Metal Roof and Siding Systems by Uniform Static Air Pressure Difference.

B. American Iron and Steel Institute (AISI)

1. AISI D100-16: Cold-Formed Steel Design Manual, [2016 Edition].
2. AISI S100-16: North American Specification for the Design of Cold-Formed Steel Structural Members, [2016 Edition].

C. American Institute of Steel Construction (AISC)

1. ANSI/AISC 360-16: - Specification for Structural Steel for Buildings, [2016 Edition].

D. 2015 Florida Product Approval FL9352-R4, FL17626

1. FL 9352.1 22 GA. 18" Wide 238-T over Roof Hugger Re-Roofing System
2. FL 9352.2 26 GA. PBR over Roof Hugger Re-Roofing System.
3. FL 9352.3 24 GA. PBR over Roof Hugger Re-Roofing System.
4. FL 9352.4 22 GA. PBR over Roof Hugger Re-Roofing System.
5. FL 9352.5 24 GA. Super Lok 16-24 over Roof Hugger Re-Roofing System.
6. FL 17626.1 24 GA. 18" Wide 238-T over Roof Hugger Re-Roofing System.

1.4 SUBMITTALS

- A. Comply with Section 01 33 00 - Submittals.
- B. Product Data: Submit manufacturer's product data, including installation instructions.
- C. Shop Drawings: Submit manufacturer's shop drawings for sub-purlins indicating gauge, yield strength, flange and web sizes, cut-out dimensions, and punch pattern for attachment holes in base flange.
- D. Design Data: Submit design data from independent engineering firm indicating table of wind uplift capacity of sub-purlins.

Product Guide Specifications

1.5 DELIVERY, STORAGE, AND HANDLING

- A. Delivery: Deliver materials to site in manufacturer's original, unopened bundles, containers, and packaging, with labels clearly identifying product name and manufacturer.
- B. Storage:
 - 1. Store materials in accordance with manufacturer's instructions.
 - 2. Protect sub-purlins from corrosion, deformation, and other damage.
 - 3. Store sub-purlins off ground, with 1 end elevated to provide drainage.

1.6 EXISTING ROOF SYSTEM AND PRE-CONSTRUCTION INSPECTION

- A. The existing roof is a *[Insert existing roof description here per specifier notes below]*
- B. Conduct a detailed inspection of the existing roof(s) to identify any existing roof elements that are a cause for concern such as: panel deterioration, structural deterioration, equipment curbs, plumbing and electrical penetrations, special flashing requirements, and any other items that should be submitted to the Architect [Engineer][Consultant] for review and evaluation.
- C. Perform a detailed survey of the existing roof(s) and confirm the existing panel dimensions, type and profile. In the case of existing standing seam roofing it should be determined if the existing roof employs standard or tall clips. If high panel clips are existing, the standoff dimension must be determined.
- D. Record field measurements on the existing roof geometry including width, length, eave height, roof pitch and purlin spacing. This information is to be forwarded to the retrofit sub-framing system manufacturer for coordination and integration into the design and installation documents.

1.7 DESIGN REQUIREMENTS

- A. General
 - 1. Design for approval and installation in accordance with the Contract Documents, a complete retrofit sub-framing and metal roof panel assembly as a structural package.
 - 2. Engineer and factory fabricate sub-framing system in accordance with applicable references.
 - 3. Coordinate design with the retrofit sub-framing manufacturer and the metal roof panel manufacturer to perform as one engineered structural package where the metal roof system controls the placement of sub-framing members.

Product Guide Specifications

4. Any additions/revisions to sub-framing members as a result of field conditions and/or demands, shall be the contractor's responsibility, and shall be submitted for review and approval by the manufacturer.

B. Engineering Design Criteria:

1. Building Code: *[IBC 2018/ASCE7-2016, FBC 2016, IBC 2016/ASCE7-2012, BOCA, Florida Building Code, Etc.]*
<Specifier Notes: codes are Mutually Exclusive, specifier should confirm which code has been adopted by the State or local governing code body for the project, codes should not be mixed.
2. Additional Requirements: *[None, Factory Mutual, Underwriters Lab, US Army Corps of Engineers Standard, Miami Dade, Other]*
<Specifier Notes: These additional requirements are mutually exclusive and can exceed or be below current code requirements review before specifying.
3. Occupancy Group: *[Assembly-A, Business-B, Educational-E, Factory Industrial-F, High-Hazard-H, Institutional/Industrial-I, Mercantile-M, Storage-S, Etc.]*
4. Occupancy Category: *[I (Low Hazard), II (General), III (300+Occupancy), IV (Essential)]*.
5. Importance Factor: *[0.87, 1.0, 1.15] (IBC 2009 or earlier only)*
6. Minimum Roof Snow Load: *[XXX] PSF.*
7. Ground Snow Load: *[XXX] PSF.*
8. Wind Speed: *[XXX] MPH, 3 Second Gust.*
9. Exposure Category: *[B, C, D]*.
10. Enclosure: *[Enclosed, Partially Enclosed, Open]*.

PART 2 - PRODUCTS

2.1 MANUFACTURER QUALIFICATIONS

- A. Manufacturer shall have a minimum of five years' experience in manufacturing and fabrication of retrofit sub-framing systems of this nature.
- B. Light-gauge steel sub-framing components specified in this section shall be produced in a factory environment by roll forming and press-brake equipment assuring the highest level of quality control.
- C. Acceptable Manufacturers



Product Guide Specifications

1. Roof Hugger, LLC, P.O. Box 1027, Odessa, Florida 33556. Toll Free Phone (800) 771-1711. Toll Free Fax (877) 202-2254. Phone (813) 909-4424. Fax (813) 948-4742. Website: www.roofhugger.com. E-Mail: sales@roofhugger.com.

2. Other manufacturers must submit a request for approval prior to the established bid date according to applicable Division 1 Section(s) and shall be equal to Roof Hugger, LLC.

2.2 RETROFIT STEEL SUB-PURLINS

A. Standard Retrofit Factory-notched Sub-Purlins: "Roof Hugger".

B. Description:

1. 1-piece, custom-notched and punched, Z-shaped section.
2. Pre-punched to nest over existing through-fastened, low clip and high clip standing seam roof panel ribs for low-profile attachment.
3. Pre-punched for attachment fasteners.
4. Integrally formed Anti-Rotational Arm as required for high clip standing seam panels.
5. Fastens directly into existing purlins, joists or structural decking with fasteners.

C. Material:

1. Galvanized steel, ASTM A 653 or A 1011, G-90, yield strength 50 KSI.
2. Thickness: *[0.060inch minimum, 16-Gauge]* or *[0.071inch minimum, 14-Gauge]*.
3. Web Height: [_____ inches] [manufacturer's standard].
4. Base Flange Width: Pre-punch base flange to manufacturer's standard unless otherwise specified.
5. Top Flange Width: Nominally 2inches with 0.25inch minimum stiffening lip unless otherwise specified.
6. Length: Nominally 10 feet long, plus an additional +/- 1inch top flange extension for part lap or per manufacturer's recommendations.

D. Attachment Fasteners/Anchorage

1. "Standard" Roof Hugger Sub-Purlin:

- a. Attachment to Existing Purlins/Joist/Decking: [two- 1/4"--14 x 1-1/2" inch], DP3 self-drilling screws.

Product Guide Specifications

- b. Existing Purlin Strengthening, Top Flange Lap Connection: [two, #10-16 x 1 inch] pancake head screws through overlapping sub-purlin top flanges, joining them into a continuous member, per lap connection or as specified.
 - c. Mid-Span Hugger Sub-Purlin to Sub-Rafter: [two, 1/4"-14 1 inch], DP3 self-drilling on each side of cutout and [one #10-16 x 1 inch] pancake head screw installed through sub-purlin top flange, into sub-rafter.
 - d. Mid-Span Hugger Sub-Purlin to Existing Panel: #17-14 fasteners shall be installed through the mid-span of sub-purlin into the existing roof panels as specified or per standard details (over-drilling of pre-punched hole will be required).
 - e. Fastener Length: As required to penetrate existing purlins in accordance with fastener attachment standards.
2. "Special" Roof Hugger Sub-Purlin w/ Anti-Rotational Arm:
 - a. Attachment to Existing Purlins/Joist/Decking: Typical 2-1/4"-14 x 2 inches DP3 self-drilling fastener with 1 inch standoff or as specified.
 - b. Attachment of Anti-Rotational Arm to Existing Panel: #17-14 fastener or as specified.
 3. Integral Sub-Rafters beneath the rib cut out in the sub-purlin: 1/4 inch-14 threads per inch, DP3 self-drilling fasteners install through the sub-purlin, through the integral sub-rafter, through the existing panel and into the existing purlin, rafters or joist; quantity as specified by design (typically 4 per intersection).
 4. Sub-Rafter Hat Channels for designated high load areas:
 - a. Attachment to Existing Purlins, Trusses, Rafters or Joist: 1/4"-14 threads per inch DP3 self-drilling screws.
 - b. Length as required for minimum required penetration into truss, rafter or joist.
 5. Sub-Purlin Hat Channels: Attachment to installed sub-rafters: 1/4 inch-14 threads per inch, DP3 self-drilling fasteners, quantity as specified.

PART 3 - EXECUTION

3.1 EXAMINATION

- A. Examine existing roof areas to receive sub-purlins. Notify Architect [Engineer][Consultant] if areas are not acceptable or structurally adequate. Do not begin installation until unacceptable conditions have been corrected.
- B. Verify existing purlins and eave struts are in good serviceable condition, without rust-thru of flanges.
- C. Field Verify Before Ordering of and Installation of Sub-Purlins:
 1. Existing panel profile and panel rib dimensions.

Product Guide Specifications

2. Existing panel run-out by measuring roof over several 20-foot areas to confirm panels were installed on module and in-square. Note variations.

3.2 INSTALLATION OF SUB-FRAMING AND OTHER ROOFTOP APPURTENCES

- A. Install sub-purlins in accordance with manufacturer's instructions at locations indicated on the standard details or Engineered Drawings if provided.
- B. Limit installation of sub-purlins to amount that can be roofed over each day.
- C. Install [1] [2] [3] fasteners per linear foot or as directed by Manufacturer.
- D. Install sub-purlins directly over existing purlins and fasten to existing purlin through existing panel pan section.
- E. If integral sub-rafter are used, loosely lay Sub-rafters over the existing panel high ribs and between the existing purlins. Sub-rafter spacing and number of fasteners shall be as specified on the [engineered Drawings] [applicable Roof Hugger, Florida Product Approval].
- F. Press the Roof Hugger sub-purlins over the sub-rafters on the existing purlin lines in areas where they are specified and install [1/4"-14 DP3 screws] [fasteners shown on engineered Drawings] through the base flange of the sub-purlin, through the sub-rafter and then into the existing purlins being careful to maintain the alignment of the sub-rafters.
- G. Install sub-purlins onto the integral sub-rafters between the existing purlins as specified with 1/4"-14 threads per inch, DP3 fasteners, typically one fastener on each side of the sub-rafter unless otherwise specified.
- H. Where the sub-purlin is attached to the existing roof panel the pre-punched base flange hole should be drilled out to the correct diameter to allow for the installation of a #17-14 fastener through the Roof Hugger and into the existing roof panel.
- I. Where the sub-purlin passes over the fitted sub-rafter, fasten through the top flange of the sub-purlin with a #10-16 pancake head fastener into the top of the new fitted sub-rafter.
- J. Removal of Existing Roof Fasteners: Do not remove existing roof fasteners unless installation of sub-purlins over fasteners causes sub-purlins to "roll" or "porpoise". Some distortion of base flange of sub-purlins caused by existing roof fasteners is normal.
- K. Skylights:
 1. Install sub-purlins over existing skylights prior to removal of the old skylight.

Product Guide Specifications

2. Modify existing skylights according to provisions of Section 08 60 00.
 3. Seal gap between existing metal roof and new metal roof with sheet metal trim to prevent air infiltration into the newly created roof cavity.
- L. Existing Rooftop Components and Equipment
1. When mechanical equipment locations conflict with retrofit roof sub-framing components, the contractor will provide additional framing that accommodates the relocation, replacement or re-flashing of the equipment. Submit construction details for this condition to the Architect [Engineer][Consultant].
 2. When electrical service and equipment needs to be removed, extended and reinstalled at the new metal roof system height/plane, extend the wiring in accordance with the Section 26 05 00, local building and electrical codes.
 3. Comply with provisions Section 07 40 00, Section 22 05 00 and local building codes for extending, relocating and flashing vent pipes.
 4. Comply with provisions Section 07 40 00, Section 23 31 00 and local building codes for extending, relocating ducts and curbs.
- M. New Equipment within the New Roof Cavity
1. Review all clearances, attachment requirements, penetrations, and other critical details as necessary for the proper installation of any equipment to be installed within the new roof cavity.
 2. Obstructions with new sub-purlins shall be avoided. If cutting of sub-purlins is necessary, a continuous top flange must be provided to provide continuous bearing for the new metal roof system.
- N. New Insulation Between Old and New Roofs
1. Insulation is optional and not required. If the new roof is standing seam a foam spacer should be used between the Roof Hugger sub-purlins and the pan of the new roof panel to minimize possible "Panel Rumble". Consult panel manufacturer for their recommendations.
 2. Review insulation requirements for the building. Insulation can easily be added to fill the new cavity in either fiberglass or rigid insulation.
 3. Note the depth of the Roof Hugger sub-purlins will be affected by the insulation requirements and corner and edge reinforcement if required. Contact Roof Hugger to confirm product dimensions best suited for project.
- O. Ventilating Between Old and New Roofs
1. Ventilation is recommended for all roof cavities insulated and uninsulated.
 2. Review ventilation details with panel supplier.

END OF SECTION

Hugger Installation

RECEIVING MATERIALS:

ROOF HUGGERS are typically placed on wood pallets 3'-5' wide and approximately 10' long weighing up to 5,000 lbs. ROOF HUGGERS are shipped via closed van for "LTL" less than truckload quantities or flatbed for truckload quantities. The installer is responsible for unloading the material and providing the suitable equipment to safely unload the material from the delivery truck.



Upon receipt of material, check for damage; if damage is found, please note the damage on the carriers Bill of Lading at the time of delivery. Notify ROOF HUGGER, Inc. of this damage within 48 hours

HANDLING: Proper care is required while unloading to prevent personal injury or material damage. Band straps should never be used for pulling or lifting of the pallets. If the pallets are to be lifted onto the roof, confirm the structure has adequate capacity first. If the structure is capable, the pallet should only be placed above the existing structural frames, 1-pallet per frame maximum unless otherwise directed by the engineer of record for the project.

INSTALLATION: Unless otherwise noted, install Huggers only directly over and into existing purlins through the existing panel pan section. (HUGGERS are normally installed with the top flange pointing up the roof slope.)

Wherever possible, layout new panels as to minimize the possibility of new panel fasteners or attachment clips from falling on the cut ends of the ROOF HUGGERS. Standing seam systems can be ordered with a narrower starter panel to offset the new panel from the existing panel module. If landing on the cut ends is

unavoidable then attach the adjacent HUGGERS overlapping top flange ends with (2) #10 pancake



fasteners in addition to the clip fasteners or back lap the HUGGERS one full corrugation to produce a double thickness and continuity of the top flange across the lap.

SPECIAL CONSIDERATIONS: Weathertightness: During erection, prior to the installation of the new roof panel the ROOF HUGGERS are NOT WEATHERTIGHT. It is recommended that only the amount of HUGGERS to be covered with new roof panels be installed in a given workday. Mastic can be placed beneath the ROOF HUGGERS at the attachment points to minimize water intrusion during construction but this may not provide a complete water seal.

Flashing and Trim: Rake angles, trims, curbs and flashings are not provided by ROOF HUGGER. Consult your panel manufacturer for the necessary details and required materials to meet their design requirements. ROOF HUGGER is available to discuss any special situations.

Bridging: Bracing or bridging may be required where the Hugger height exceeds 3-3/8". Consult your local engineer for specific requirements for your locale. We can provide details of previous installations upon request.

Out of Module Existing Roof Panels: In some rare cases, the existing roof panels may be installed so poorly the they do not maintain the proper panel rib spacing (i.e.: a 12" o.c. "R" panel may gain 1/8" per L.F., so in 10' the roof would measure a gain of 1-1/4") The ROOF

Hugger Installation

HUGGER “notches” are over cut to allow for most conditions, however some cases may exceed our tolerances. If this occurs, the ROOF HUGGER may be cut to allow it to fit properly. Use care to avoid fasteners or clips from falling on the resulting gap, back lap the HUGGERS if necessary.

Installing Over Skylights: DO NOT REMOVE EXISTING SKYLIGHTS prior to installing ROOF HUGGERS. Run HUGGERS across existing skylight and screw into position.

Cut out and trim opening if new skylights are to be installed above, or leave panel in position if skylights are to be eliminated. Removal of skylight prior to installing HUGGERS may result in an undesirable depression of the new roof over the old skylight area.

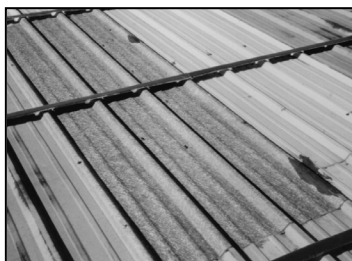

If skylights are to be installed where interior condensation could be an issue, it is desirable to replace the old skylight with a new one and install another new skylight above it to minimize any condensation issues in this area. Consult your local moisture control professional.

Existing Standing Seam Roofs with Tall Clips and/or Thermal Blocks:

Existing roofs that have tall clips (clips that hold the roof ½” to 1½” above the purlin) require special attachment.

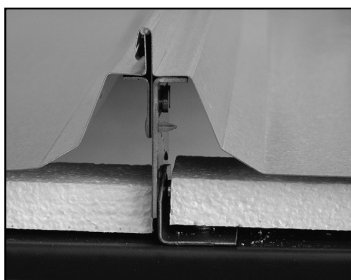

A special self-drilling fastener or a fastener with a standoff sleeve will be provided by ROOF HUGGER unless otherwise specified.



Note: Field verify the standoff by drilling a small hole over the purlin and measure the distance between the existing panel and the existing purlin (typically 1”). The number of fasteners per L.F. is determined by the specific project design, generally four (4) fasteners are required every 24” or three (3) fasteners every 16”, however higher loads could require additional attachment. Since the ROOF HUGGER Sub-purlins cannot be pulled down to the existing purlin because of the standoff clip they have been specially designed with an “*anti-rotational arm or tab*”.

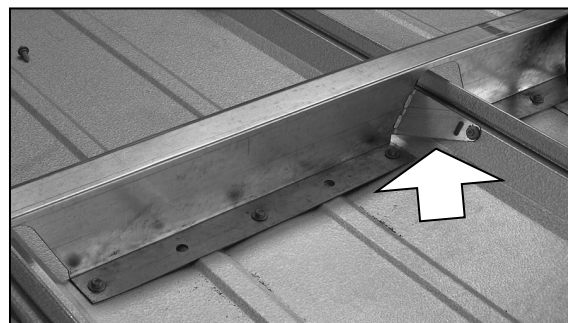

This arm prevents the ROOF HUGGER from rolling front to back under load and it is attached with a #17 fastener into the side of the existing panel high rib. Note that if the anti-roll tab is above the side of the existing high rib the ROOF HUGGER may not be pulled fully down into its correct position.

Also note that more holes may be punched into the base flange than are required for attachment. Eave attachment is generally with ¼”-14 x 1-½” Tek-3 (T-3) fasteners since tall clips are not normally used here.

Hugger Installation

EXISTING FASTENERS:

The existing fasteners can remain provided they do not cause the ROOF HUGGERS to “porpoise” up or roll front to back out of plane with the existing roof.



(Typical “R” Panel installation showing the bending of the bottom flange caused by the existing fastener is normal.)

Fasteners located in the center of the pan of the existing sheet may need to be removed. On an 8”-12” o.c. panel this should only occur at a panel lap, ridge cap or eave area. Narrower ribbed panel such as 6” o.c. panels, with fasteners in the center of the sheet pan, may require removal of all fasteners.

ROOF HUGGER can provide special punching to minimize removal of these fasteners if requested during the pricing and ordering of the HUGGERS.

ROOF HUGGER FASTENERS AND FASTENER PATTERNS: ROOF HUGGERS are typically attached with ¼”-14, self-drilling, T-3 fasteners, 14 treads per inch, 1-¼” to 1-½” in length ¼”-14 x 1-½”. The number of fasteners per L.F. is determined by ROOF HUGGERS project design or as specified by the engineer of record. Generally speaking, (2) fasteners are required per L.F. for proper attachment. Holes are pre-

punched in the bottom flange of the HUGGERS for installation of the fasteners. Note: There may be more holes punched in the base flange than are required for attachment. ROOF HUGGER can provide fasteners if requested.

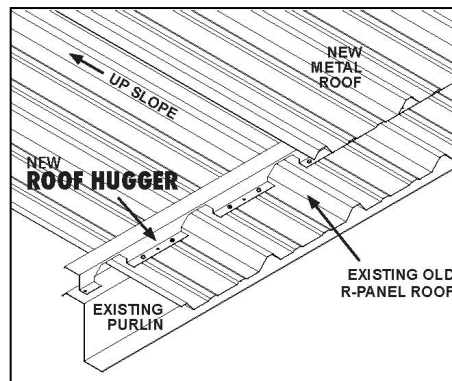

Installing on Existing Corrugated Panels: ROOF HUGGERS Corru-Fit product for existing 2.50”, 2.67” and 2.75” corrugated panels up to 1.25” tall is a 2-part system. A 1.25” triangular shaped spacer and a 1.5” tall slotted Zee. Spacer/fastener spacing is per engineering design, (2.75” total assembly height). Call ROOF HUGGER for estimated loads and spacing (subject to review). Lap ends are designed to align and share a common fastener.

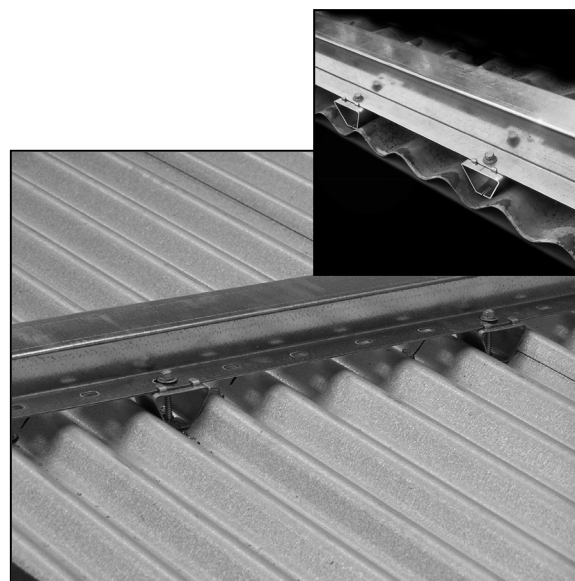

Hugger Installation

Midspan Attachment: When the existing purlin spacing is not adequate to meet code required loads, ROOF HUGGER will supply an Integral Sub-Rafter System or Hat Grid (see Grid Framing). An Integral Sub-Rafter System means the Sub-Rafters are specifically built to fit the cutout provided in the ROOF HUGGER Sub-Purlin. See page 32 & 33 for installation details.

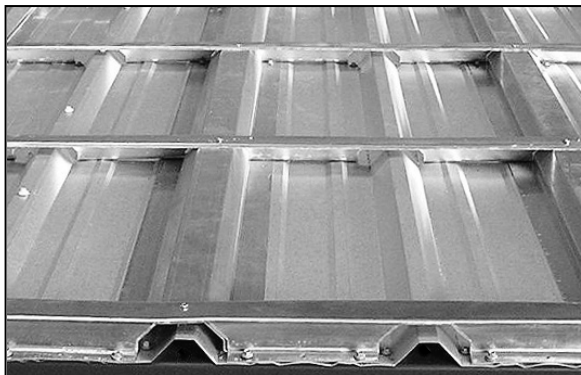

Note: If integral (fit under the HUGGERS) structural Sub-Rafters are provided, loosely place hats and HUGGERS in position prior to installing any fasteners to prevent alignment problems in these areas.

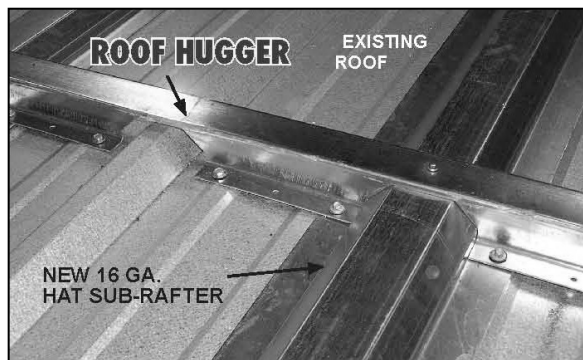

The Sub-Rafters will typically fit over the top of the major panel Ribs between 12"-24" centers. The Sub-Rafters will span from existing purlin to existing purlin and the ROOF HUGGERS will be placed on and into these members. The parts over the existing purlins will have ¼"-14 T3 fasteners installed through the HUGGERS, through the Integral Sub-Rafter, through the existing roof panel and into the existing purlin. Oversize pre-drilling of the HUGGERS at Integral

Sub-Rafter is recommended. The number of fasteners will be per the engineered design. ROOF HUGGERS that are installed "mid-span" between the existing purlins are attached to the Integral Sub-Rafters with ¼"-14 T3 fasteners as specified and if the HUGGERS are to be attached into the old panels the existing ¼" hole in the HUGGER should be drilled out and a #17 fastener installed through the HUGGER into the existing panel, (1) one each side of the major rib. A #10-16 pancake head fastener may also be required between the top flange of the HUGGER and the top of the Integral Sub-Rafter.

Existing Purlin Strengthening: HUGGERS have been tested for the effect they have on strengthening the existing purlins to accommodate the weight of the HUGGERS and new roof panel as well as additional code required snow loads and increased wind loads. If required by design, the following explains the proper Hugger lapping conditions.

Should a panel clip fall in the lap area, (2) clip

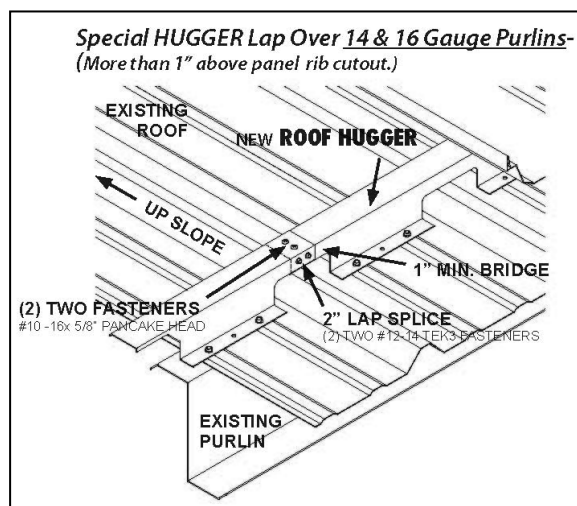

fasteners will replace (2) pancake fasteners provided the clip fasteners penetrate both overlapping flanges of the HUGGER. Higher profile HUGGERS (1" or more of material above the rib cutout) receive (2) #10-16 x 1" (or equal)

Hugger Installation

pancake head, self-drilling fasteners in the top flange lap and (2) ¼" x 14 x 1-½" T3 in the vertical web.

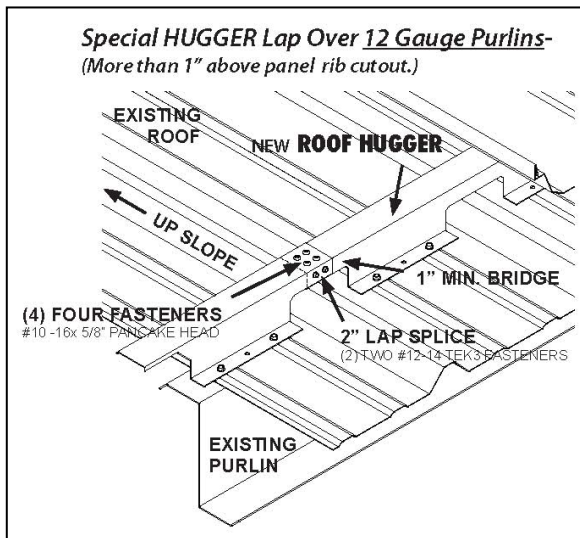
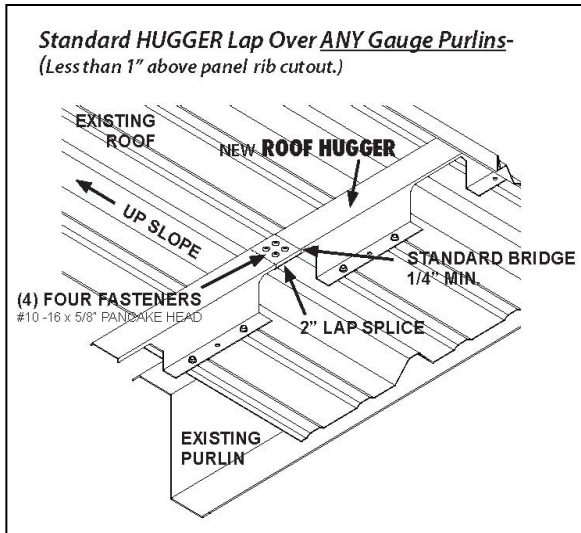

Grid Framing: When needed in the corners and edges, hat channel grid framing may be used. Hats that run parallel to the existing panel ribs between the existing purlins are called "Sub-Rafters". They are normally installed 12"- 24" o.c. with (4) ¼" x 14 x 1¼" T3 fasteners into the existing purlins and are designed to transfer the panel loads back to the existing purlins. The hats that run across these members are called

"Sub-Purlins" and they attach on top of and perpendicular to the sub-rafters. They are normally attached with (2) ¼" x 14 x 1-½" T3 fasteners. In some cases, fasteners will attach the sub-rafters to the existing roof panels. See 34 & 35 for installation.

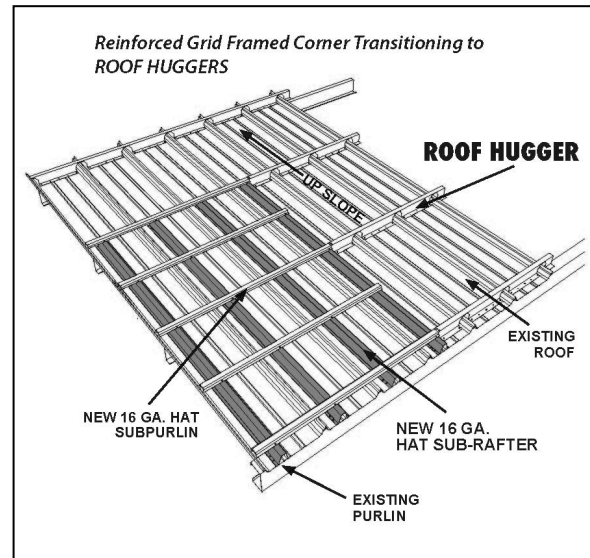

Eave/Ridge Blocking: To control the direction of motion on floating clip standing seam metal roof systems a "Point of Fixity" is typically required. ROOF HUGGER may specify that one or more purlin lines at the eave or ridge have extra framing to accomplish this. *(See detail below or refer to contract drawings for details.)*

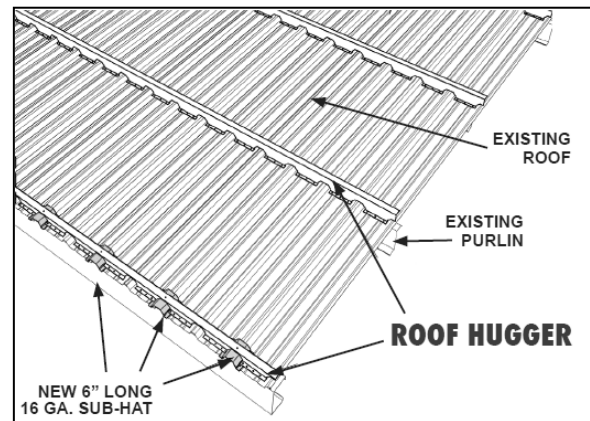

Hugger Installation

Fastener Types: The following fasteners are those used in typical Roof Hugger installations as indicated below. Please note their specific use as described in this section and manual.

Typical Screw Nomenclature: ¼” -14 x 1 ¼” DP3 or T3 is explained this way: ¼” is screw diameter, – 14 is threads per inch, x 1 ¼” is length and DP3 or T3 is the type of drilling tip. Please note that in lieu of DP3, Roof Hugger uses Tek-3 or T3 in our standard details and other construction documents to describe any self-drilling screw.



Size: #10-16 X 1” TEK-3

Locations:

- A. Attaching Hugger top flange to sub-rafter at corner/edge wind uplift zones
- B. At Hugger laps for Purlin Strengthening



Size: #17-14 AB (washer typically not required)

Locations:

- A. Attaching Hugger into existing Roof panels at Mid-span locations
- B. Securing Hugger anti-rotational arm to existing Trapezoidal SSR panel rib



Size: ¼”-14 X 1½” TEK-3

Locations:

- A. Attachment of Hugger Sub-Purlin to existing purlin or joist
- B. Attachment of Hugger sub-purlin in corner/edge zone to sub-rafter, spanning between existing purlins, to create a mid-span purlin.
- C. Securing Hugger anti-rotational arm to existing Vertical Rib SSR panel rib.

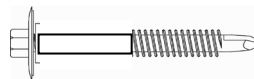

Size: ¼”-14 X 2” TEK-3 Special Stand-off Screw

Location: Attachment of Hugger to existing purlin or joist when existing Roof panel is a trapezoidal or vertical rib standing with stand-off clip and thermal spacer. **These fasteners are furnished by Roof Hugger.**

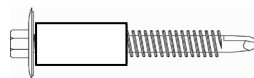

Size: ¼”-14 X 3” TEK-3 with “Spirol” spacer

When in doubt about any special situation, consult your project architect or engineer first. Roof Hugger is also available to discuss any issues or details. In this manner, problems can be avoided and the highest industry standards of a quality installation will be assured.

Step-by-Step Hugger Installation

Standard Installation (Corner/Edge Zone Framing not required)

Step 1: Install Huggers directly over and into existing building purlins with ¼"-14 TEK-3 self-drilling fasteners. Center existing panel's major rib in Hugger cut-out. Ensure Hugger straightness along purlin run by frequently monitoring dimension from existing Roof eave. Stringlines can be used if elected by Installer.

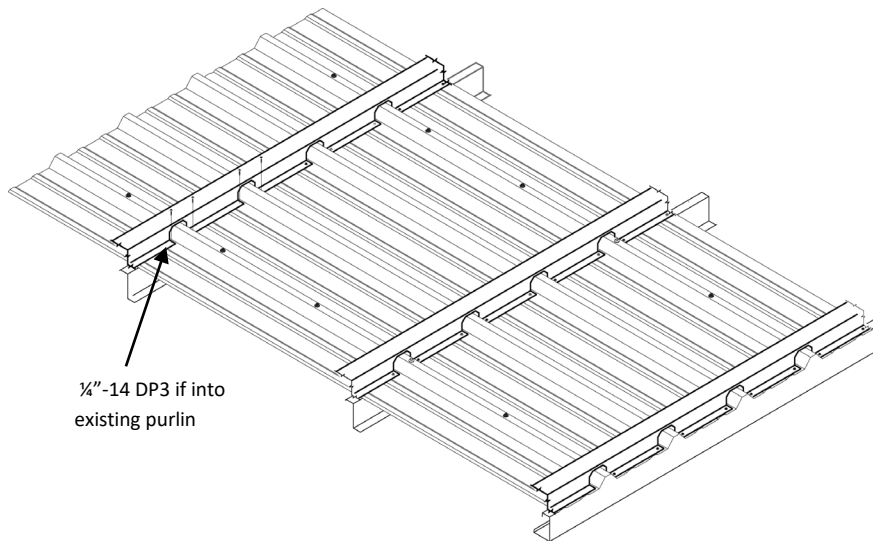

Step 2: Install metal Roof panel system in accordance with manufacturer's standards

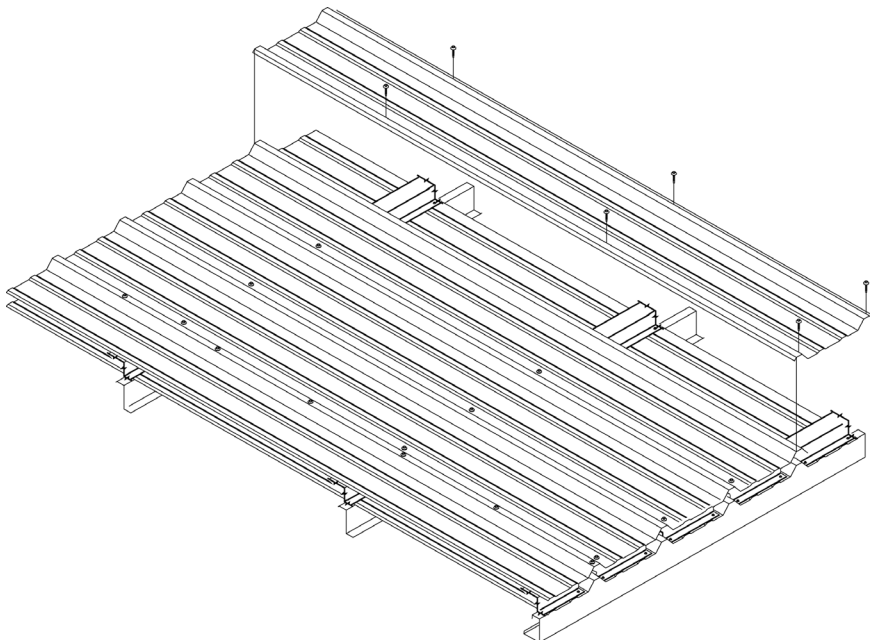

Step-by-Step Hugger Installation

Integral Corner and/or Edge Zone Framing Installation

In many cases the updated building codes have wind load requirements that are typically greater than in previous years. The new metal roof being installed will require attachment to the Roof Huggers at intervals less than those present in the existing building roof and its purlin spacing. In these cases, the design of the retrofit assembly will require Roof Hugger sub-rafters to be placed, typically 1'-2' on center, beginning at the building corner, along the low eave and running uphill, a distance determined by the design. These sub-rafters, spanning from existing purlin to existing purlin, allow the factory-notched Roof Hugger sub-purlins to be secured, not only "on" but "in-between" the existing purlin locations. The following illustrations and steps described the installation of Roof Hugger sub-rafters and sub-purlins.

NOTE: The following systems are only available to those new metal roof panel systems that have been laboratory tested over Roof Hugger sub-purlins. Roof panel systems that have not been tested and also require panel attachment less than the existing purlin spacing will normally require what we call a Hat-over-Hat sub-framing system. In these cases, the Roof Hugger sub-purlins will usually require additional web depth to properly flush out with the Hat over Hat assembly.

Step 1: Loosely place Hugger sub-rafters spaced perpendicular to Roof slope as directed (normally no more than 2'-0" o.c.). DO NOT ATTACH sub-rafters until new Huggers have been placed into position.

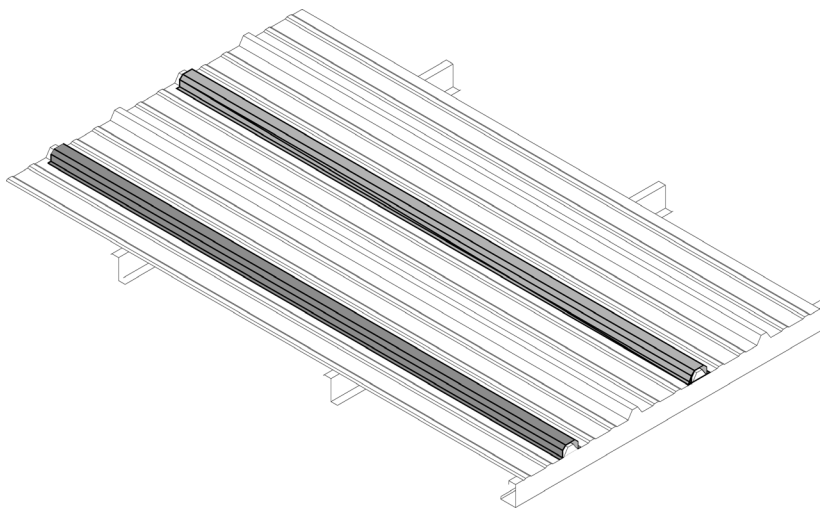

Step 2: Place new Huggers into position ensuring all new sub-framing is square and tightly fitted. Secure the positioning of the Huggers and sub-rafters by installing one ¼"-14 at juncture of the two members (Hugger top flange into top of sub-rafter). Begin final attachment of members at juncture of

Step-by-Step Hugger Installation

the Hugger and sub-rafter's base flanges for locations that are directly over an existing purlin using ¼"-14 TEK-3 fasteners at each side of sub-rafter.

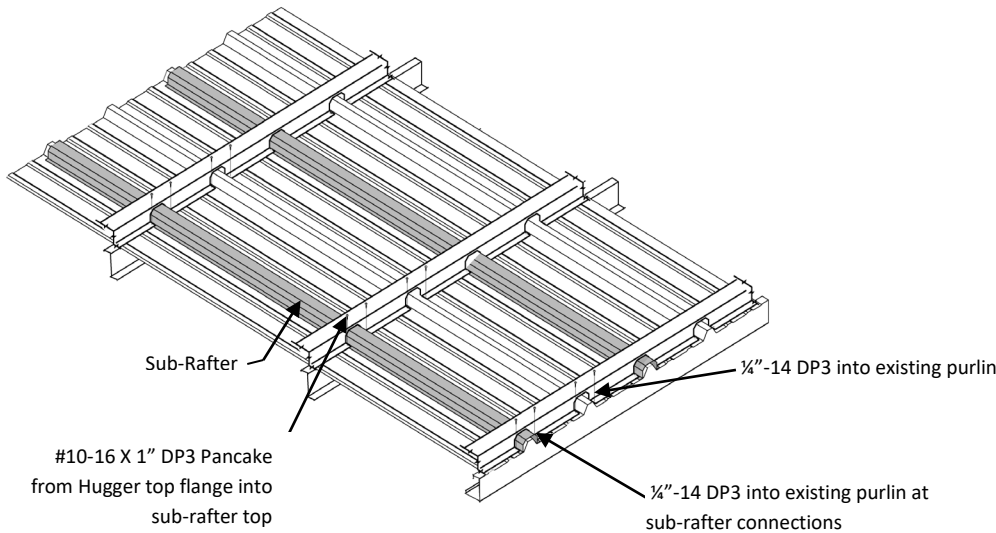

Step 3: Begin positioning mid-span Huggers as directed. These are the Huggers that will not be installed over an existing purlin, rather over the existing panel only. Once in place, install a #17-14 AB fasteners through the Hugger into the existing Roof panel at each side of the panel's major rib. Pre-drilling of Hugger may be necessary. Complete installation by installing a #10-16 TEK-3 Pancake at the intersection of each Hugger and sub-rafter. Refer to page 34 for more information.

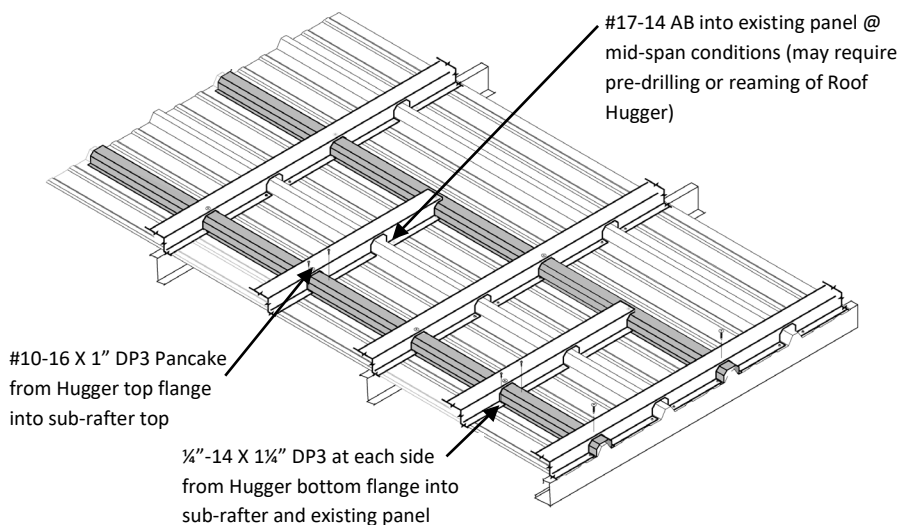

Step 3: Install metal Roof panel system in accordance with manufacturer's standards

Structural Hat Grid Framing

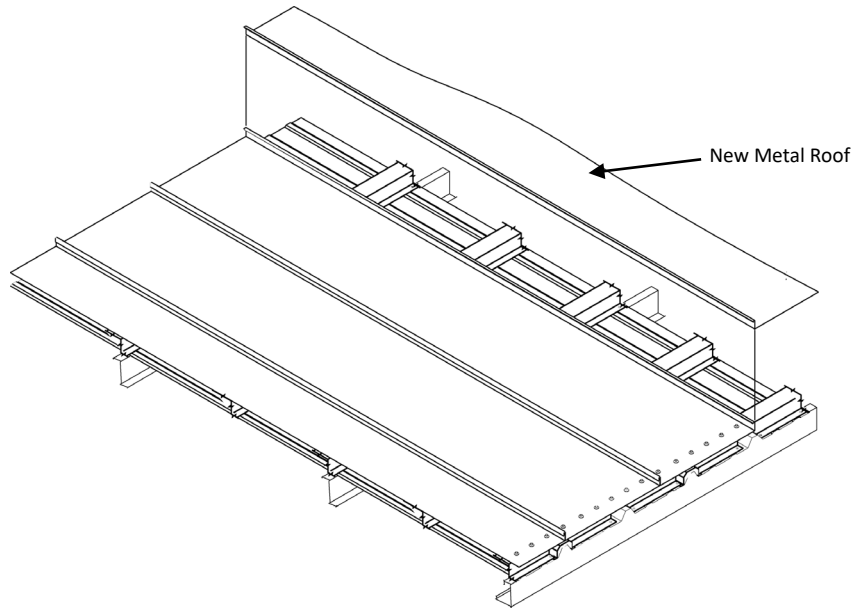

Corner and/or Edge Zone Framing Installation using Structural Hats

Dependent on panel clip attachment and wind uplift tested values, usually in higher wind zone areas, Roof Hugger will have to utilize structural 16 GA hat-shaped members to make up the corner and/or edge zone framing. The illustration below explains the difference, but you can review page 66 for more detailed information.

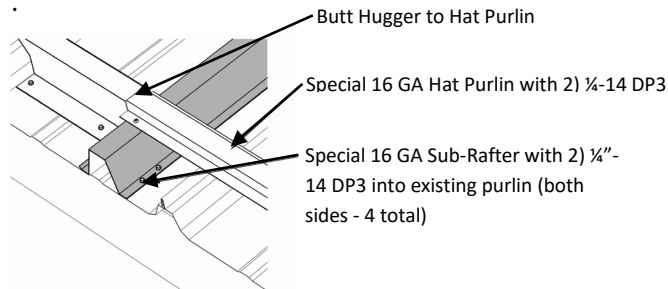

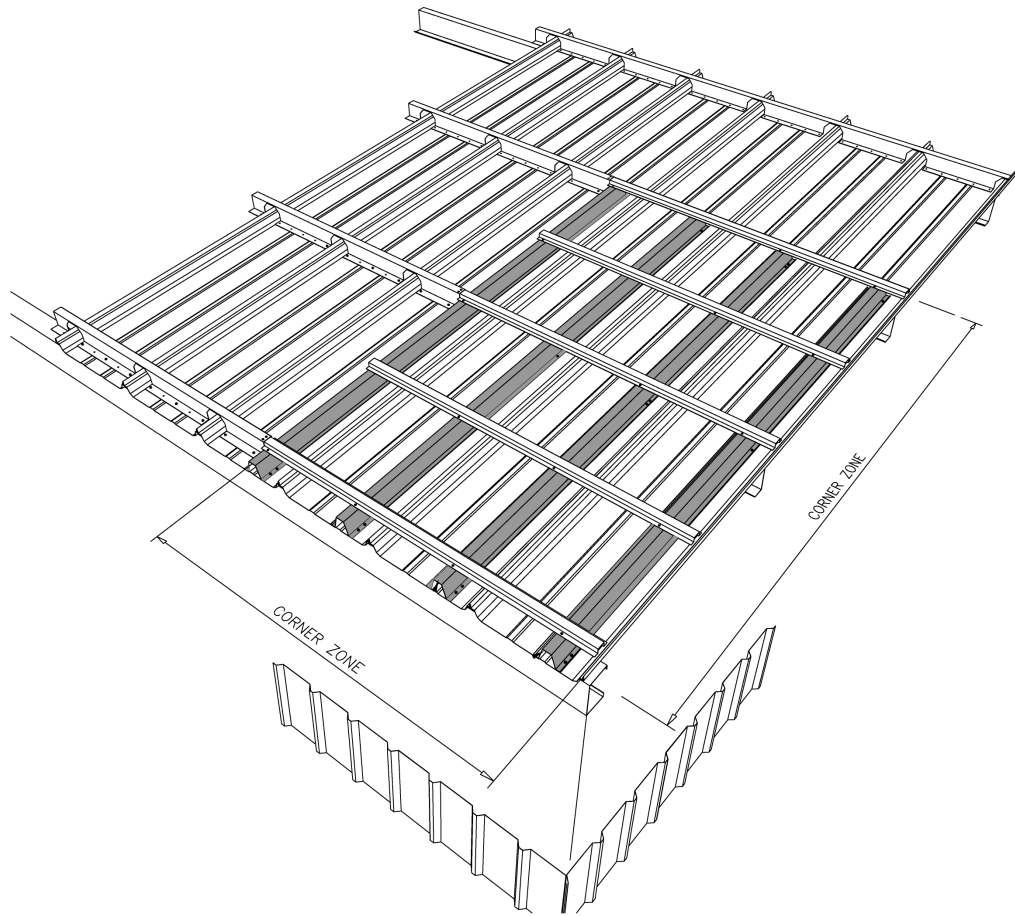

Standard Construction Details

DETAIL TYPE (2D or 3D) AND ASSEMBLY DESCRIPTION	PAGE NO.	DETAIL NUMBER
Hugger Attachments to existing purlins with various existing and new roof panel systems		
2D - new over existing panel roofs without insulation	39	HA-01-G
2D - new over existing panel roofs with vented assembly and fiberglass	40	HA-02-GV-F
2D – new over existing panel roofs with vented assembly and rigid insulation	41	HA-02-GV-R
2D – panels with Cor-A-Vent block and fiberglass insulation	42	HA-02-GV-CV
3D – new trapezoidal SSR roof over 12” o.c. “R” panel roof with Cor-A-Vent ventilation block and fiberglass or rigid insulation	43	HA-02-T/R-CV
3D – new “R” or “PBR” panel roof over existing “R” panel roof	44	HA-03-R/R
3D – new trapezoidal SSR roof over existing 12” o.c. “R” panel roof	45	HA-03-T/R
3D – new trapezoidal SSR roof over existing trapezoidal SSR roof	46	HA-04-T/T
3D – new trapezoidal SSR roof over existing vertical rib SSR roof	47	HA-05-T/V
3D – new vertical rib SSR roof over existing vertical rib SSR roof	48	HA-06-V/V
3D – new trapezoidal SSR roof over existing 7.2 Industrial rib panel roof	49	HA-07-T/7.2
3D – new vertical rib SSR roof over existing trapezoidal SSR roof	50	HA-08-V/T
3D – new trapezoidal SSR roof over existing 6”-10” o.c. ribbed panel roof	51	HA-09-T/6-10
3D – new trapezoidal SSR roof over trapezoidal SSR roof with thermal spacer and stand-off panel clip	52	HA-10-T/TSO
3D – new trapezoidal SSR roof over vertical rib SSR roof with thermal spacer and stand-off panel clip	53	HA-11-T/VSO
3D – new vertical rib SSR roof over vertical rib SSR roof with thermal spacer and stand-off panel clip	54	HA-12-V/VSO
3D – new vertical rib SSR roof over trapezoidal SSR roof with thermal spacer and stand-off panel clip	55	HA-13-V/TSO
3D – new vertical rib SSR roof over trapezoidal SSR roof	56	HA-15-V/T
3D – new vertical rib SSR roof over existing “R” panel roof	57	HA-16-V/R
3D – new trapezoidal SSR roof over existing corrugated panel roof “Corru-Fit”	58	See Corru-Fit™ Guide
Hugger and Purlin Strengthening Laps, New Roof Panel Lap and Lean-to Conditions		
2D – Hugger at new standard roof panel endlaps (For single skin panels only)	59	EL-02-G
3D – standard Hugger endlap for any gauge purlins and existing 12” O.C. “R” panel roof	60	HL-01-R
3D – special Hugger endlap for 16 and 14 GA purlins for other roof systems	61	HL-02-R/16-14
3D – special Hugger endlap for 12 GA purlins for other existing roof systems	62	HL-03-R/12
3D – vertical rib Hugger endlap over all purlins	63	HL-04-V
3D – trapezoidal Hugger endlap for all purlins	64	HL-05-T

Standard Construction Details

Hugger Corner/Edge Wind Zone Framing with various existing roof panels		
3D – Integral Huggers over existing “R” panel using sub-rafters	65	ZF-01-R
3D – Integral Huggers over existing vertical rib SSR using sub-rafters	66	ZF-03-V
3D – “Hat Grid” framing over existing trapezoidal SSR	67	ZF-04-HAT-T
3D – “Hat Grid” framing over existing “R” panel	68	ZF-05-HAT-R
3D – “Hat Grid” framing over existing vertical rib I SSR	69	ZF-06-HAT-V
Low Eave Conditions with various existing roof panels		
2D – Vented or non-vented with/without gutter – generic panels	70	LE-01-G
3D – new “R” or “PBR” panel roof over existing “R” panel roof	71	LE-02-R/R
3D – new trapezoidal SSR roof over existing “R” panel roof	72	LE-02-T/R
3D – new trapezoidal SSR roof over existing trapezoidal SSR roof	73	LE-03-T/T
3D – new trapezoidal SSR roof over existing vertical rib SSR roof	74	LE-04-T/V
3D – new vertical rib SSR over existing vertical rib SSR roof	75	LE-05-V/V
3D – new vertical rib SSR over existing “R” panel roof	76	LE-06-V/R
3D – new vertical rib SSR over existing trapezoidal SSR roof	77	LE-07-V/T
High Eave Conditions with various existing roof panels		
2D – non-vented high eave with any roof panels	78	HE-01-G
3D – new “R” or “PBR” panel roof over existing “R” panel roof	79	HE-02-R/R
3D – new trapezoidal SSR roof over existing “R” panel roof	80	HE-02-T/R
3D – new trapezoidal SSR roof over existing trapezoidal SSR roof	81	HE-03-T/T
3D – new trapezoidal SSR roof over existing vertical rib SSR roof	82	HE-04-T/V
3D – new vertical rib SSR roof over existing vertical rib SSR roof	83	HE-05-V/V
2D – vented high eave with any roof panels	84	HE-06-V/T
3D – new vertical rib SSR roof over existing “R” Panel roof	85	HE-07-V/R
Rake Conditions with various existing roof panels		
2D - new “R” or “PBR” panel roof over existing “R” panel roof	86	RE-01-R/R
2D – new trapezoidal SSR roof over existing “R” panel roof	87	RE-02-T/R
2D – new trapezoidal SSR roof over existing trapezoidal SSR roof	88	RE-03-T/T
2D – new vertical rib SSR roof over existing “R” panel roof	89	RE-04-V/R
2D – new vertical rib SSR roof over existing vertical rib SSR roof	90	RE-05-V/V
2D – new vertical rib SSR roof over existing trapezoidal SSR roof	91	RE-06-V/T
Ridges, Hips, Valleys, Roof-to-Wall Conditions and Roof Expansion Joint		
2D – non-vented ridge with any new SSR type roof systems	92	RD-01-G
2D – vented ridge with any new SSR type roof systems	93	RD-02-GV
3D – hip for any new SSR type roof systems	94	HP-01-G
3D – valley for any new SSR type roof systems	95	VL-01-G



Standard Construction Details

2D – valley for any new SSR type roof systems	96	VL-02-G
2D – valley gutter with any new SSR type roof systems	97	VG-01-G
2D – typical Lean-to Step condition or any type roof systems	98	LT-01-G
2D – pitch-break/roof-to-wall with any new SSR type roof systems	99	PB-01-G
2D – rake-to-wall with new trapezoidal SSR roof over existing “R” panel roof	100	RW-01-T/R
2D – rake-to-wall with new trapezoidal SSR roof over existing trapezoidal roof	101	RW-02-T/T
2D – rake-to-wall with new trapezoidal SSR roof over existing vertical rib SSR	102	RW-03-T/V
2D – rake-to-wall with new vertical rib SSR roof over existing “R” panel roof	103	RW-04-V/R
2D – rake-to-wall with new vertical rib SSR roof over existing vertical rib SSR	104	RW-05-V/V
2D – rake-to-wall with new vertical rib SSR roof over existing trapezoidal SSR	105	RW-06-V/T
2D – Huggers at existing panel expansion joints – New trapezoidal SSR over existing “R” panel roof	106	EJ-01-T/R
Insulated Assemblies with Thermal Resistance Values		
2D with Insulation Value Tables for Fiberglass Insulation	107-120	See Details
3D with Insulation Value Tables for Rigid Insulation	121-126	

PLEASE NOTE: All standard details were specifically created to illustrate the installation of Roof Hugger’s retrofit sub-framing systems only. Even though they include the new metal roof system and its flashing, trim and fastening methods, they are not intended to replace any metal roof manufacturer’s recommended details. Refer to your selected metal roof manufacturer’s details to comply with their requirements.

Hugger Attachment (HA-01-G)

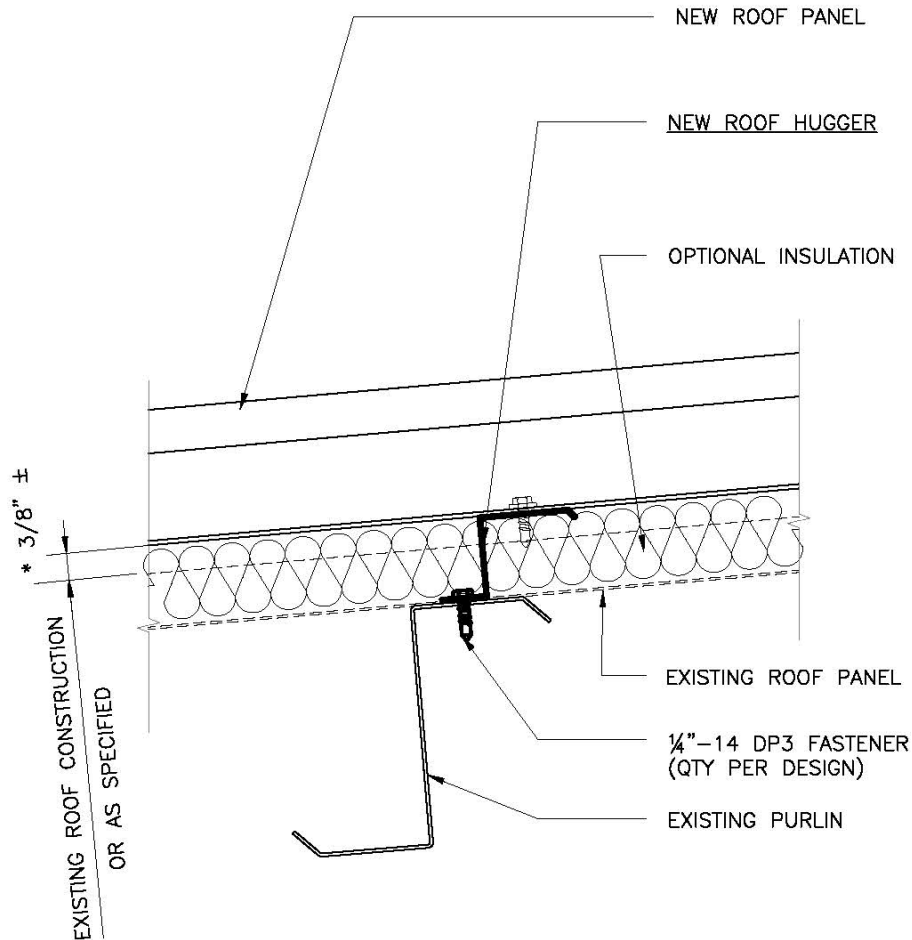

* ROOF HUGGERS ARE MANUFACTURED TO ALLOW 3/8"–1/2" MIN. ABOVE EXISTING PANEL RIB/SEAM. THIS DIMENSION MAY VARY TO ACCOMMODATE MATERIAL UTILIZATION AND SCRAP REDUCTION ON CUSTOM ROOF HUGGERS

NOTES:

1. ALL FASTENERS NOT BY ROOF HUGGER UNLESS NOTED OTHERWISE.
2. ALL NEW ROOF SYSTEMS INCLUDING PANEL, FASTENERS, TRIM AND ACCESSORIES TO BE INSTALLED PER THAT MANUFACTURER'S STANDARDS.

Hugger Attachment (HA-02-GV-F)

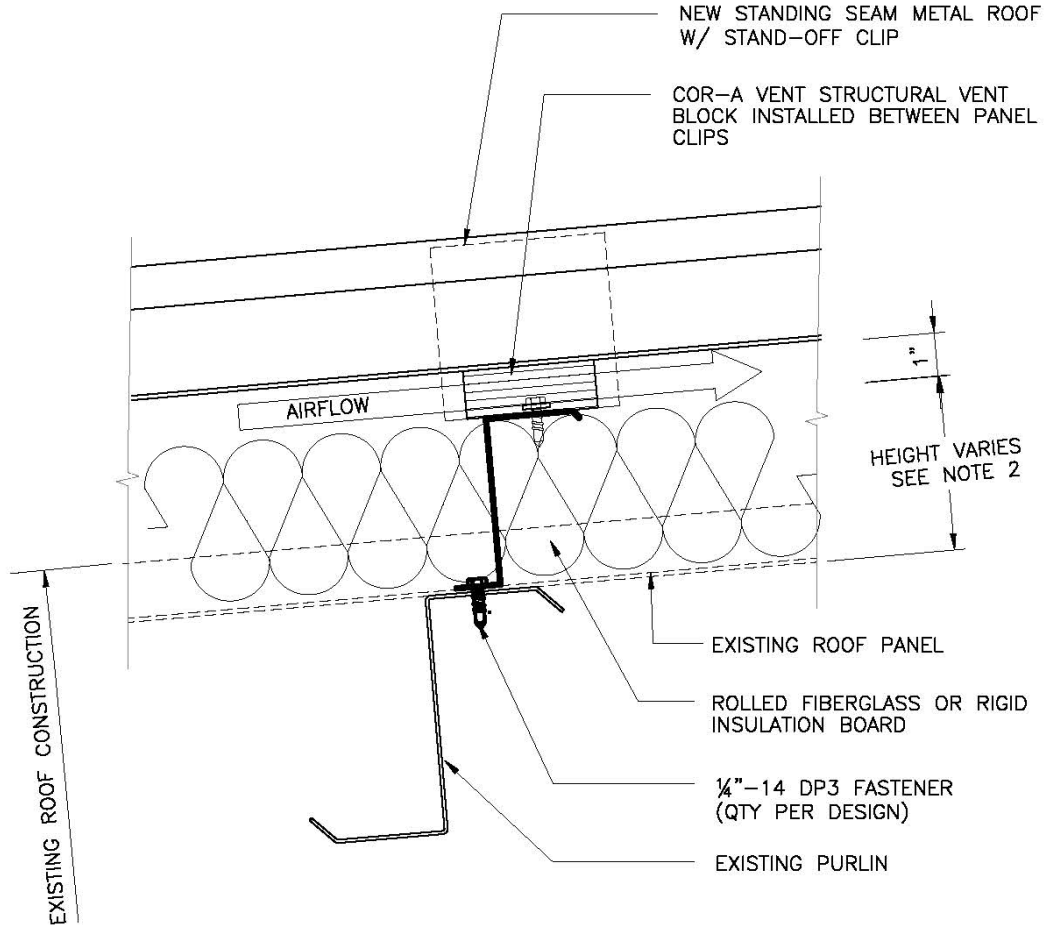

NOTES:

1. ALL FASTENERS NOT BY ROOF HUGGER UNLESS NOTED OTHERWISE
2. ROOF HUGGER HEIGHT BASED ON EXISTING ROOF PANEL PROFILE AND NEW INSULATION THICKNESS.
3. ALL NEW ROOF SYSTEMS INCLUDING PANEL, FASTENERS, TRIM AND ACCESSORIES TO BE INSTALLED PER THAT MANUFACTURER'S STANDARDS.

Hugger Attachment (HA-02-GV-R)

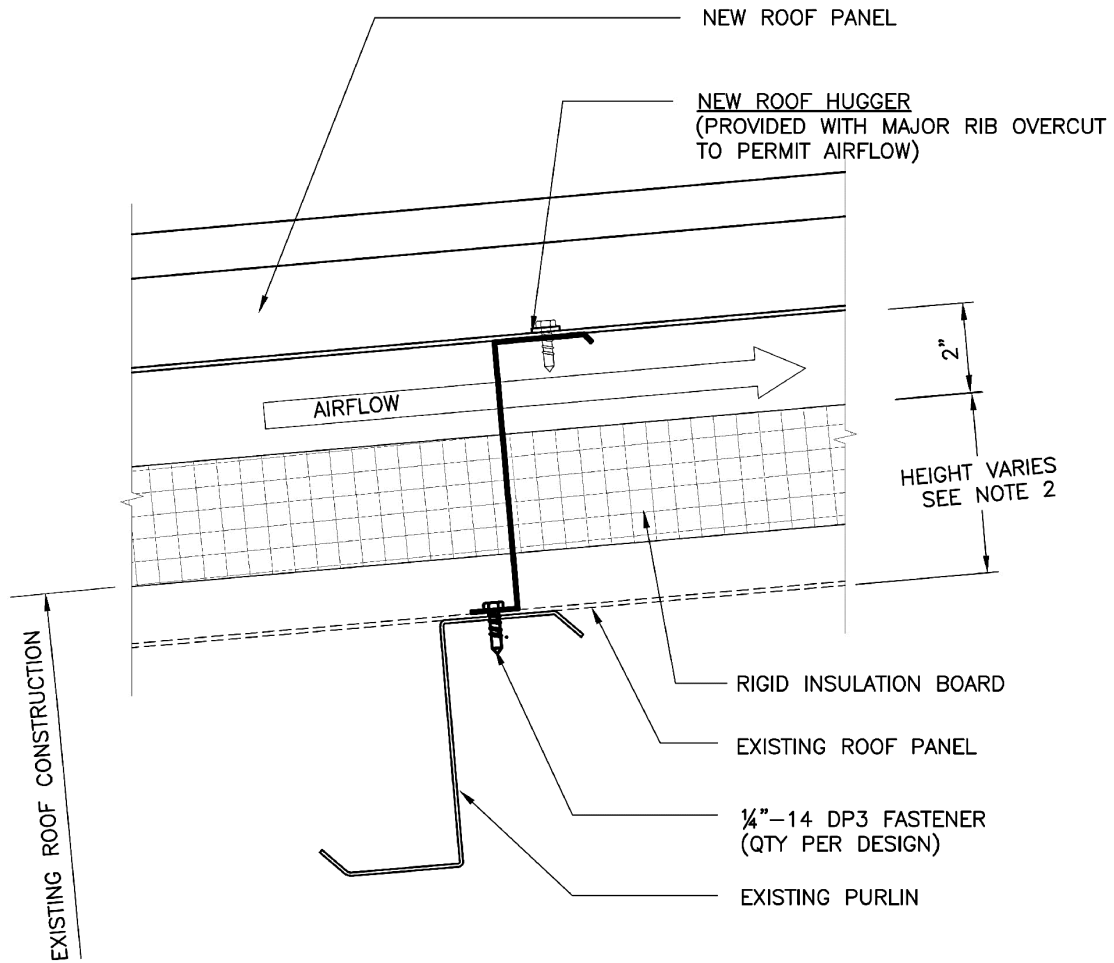

NOTES:

1. ALL FASTENERS NOT BY ROOF HUGGER UNLESS NOTED OTHERWISE
2. ROOF HUGGER HEIGHT BASED ON EXISTING ROOF PANEL PROFILE AND NEW INSULATION THICKNESS.
3. ALL NEW ROOF SYSTEMS INCLUDING PANEL, FASTENERS, TRIM AND ACCESSORIES TO BE INSTALLED PER THAT MANUFACTURER'S STANDARDS.

Hugger Attachment (HA-02-GV-CV)

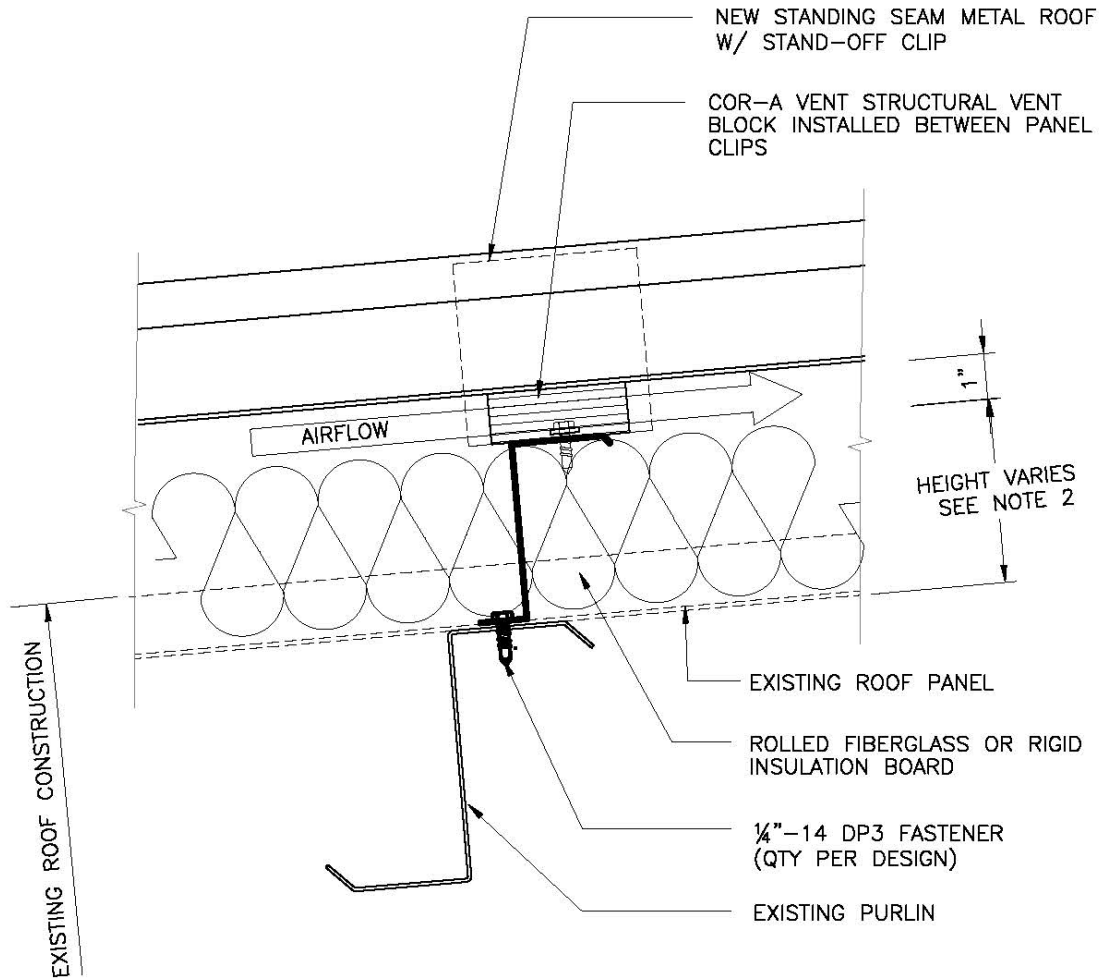

NOTES:

1. ALL FASTENERS NOT BY ROOF HUGGER UNLESS NOTED OTHERWISE
2. ROOF HUGGER HEIGHT BASED ON EXISTING ROOF PANEL PROFILE AND NEW INSULATION THICKNESS.
3. ALL NEW ROOF SYSTEMS INCLUDING PANEL, FASTENERS, TRIM AND ACCESSORIES TO BE INSTALLED PER THAT MANUFACTURER'S STANDARDS.

Hugger Attachment (HA-02-T/R-CV)

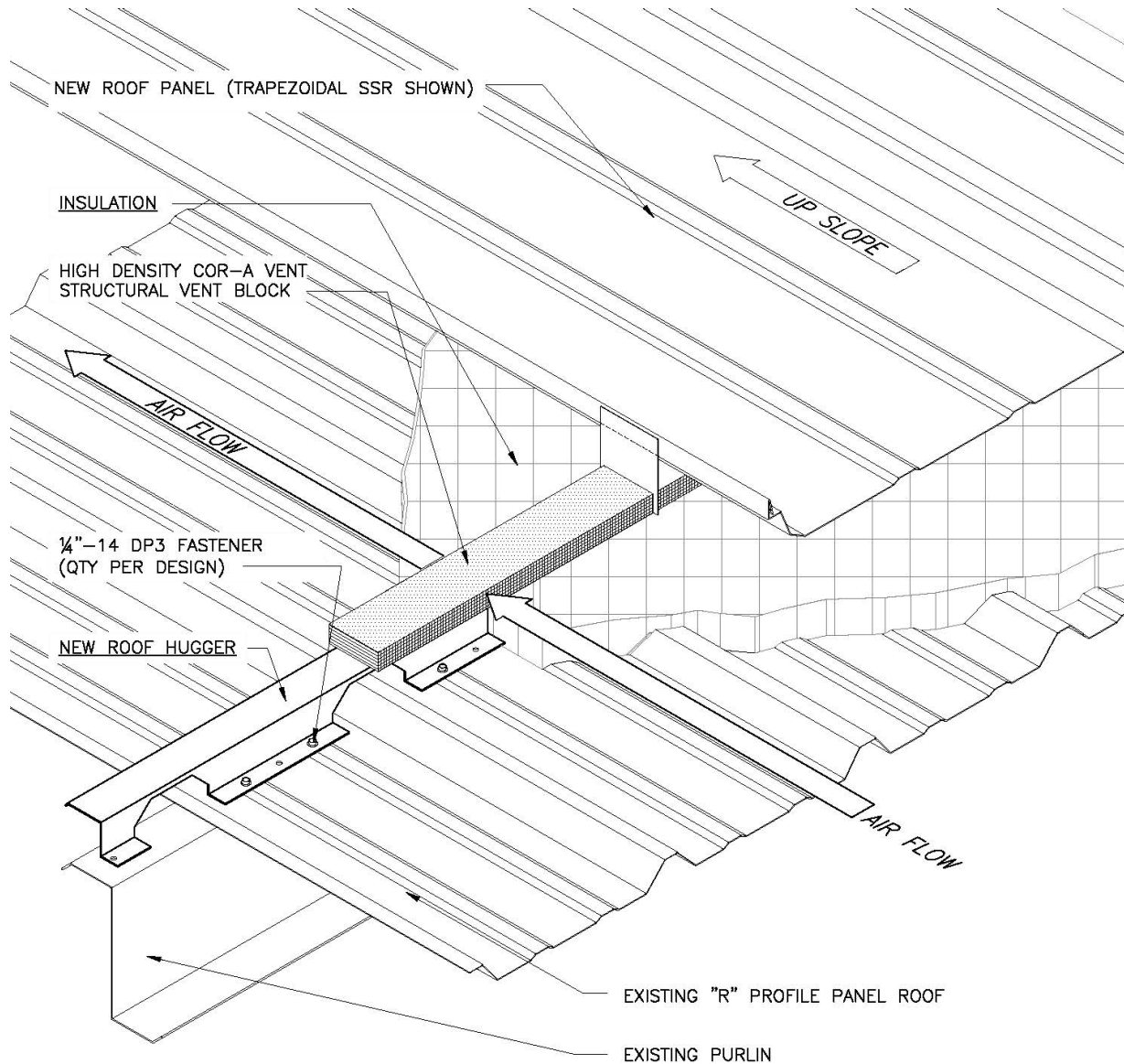
**NOTES:**

1. ALL FASTENERS NOT BY ROOF HUGGER UNLESS NOTED OTHERWISE
2. ALL NEW ROOF SYSTEMS INCLUDING PANEL, FASTENERS, TRIM AND ACCESSORIES TO BE INSTALLED PER THAT MANUFACTURER'S STANDARDS.

Hugger Attachment (HA-03-R/R)

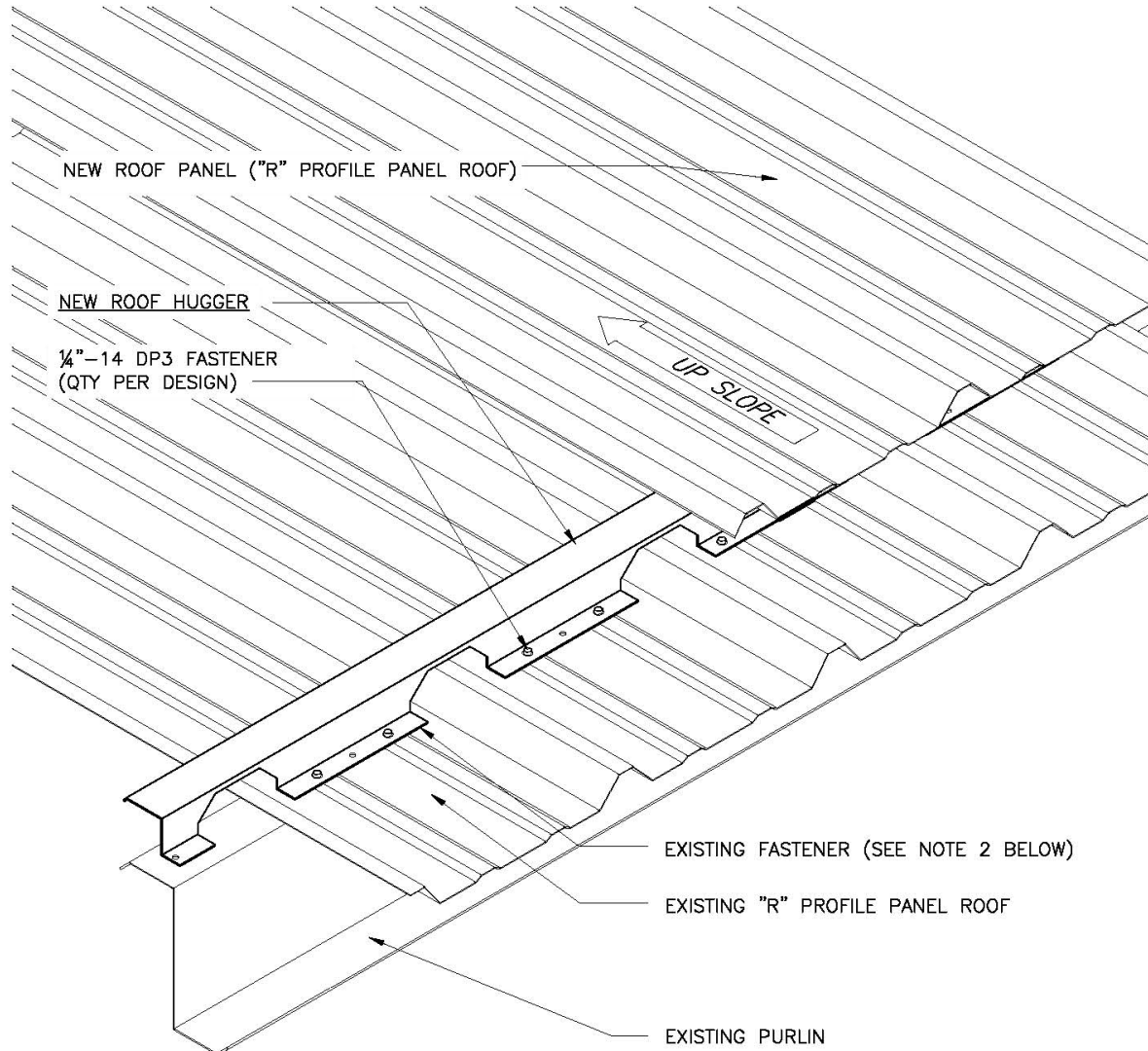
**NOTES:**

1. ALL FASTENERS NOT BY ROOF HUGGER UNLESS NOTED OTHERWISE
2. SEE ROOF HUGGER INSTALLATION INSTRUCTIONS FOR INFORMATION CONCERNING EXISTING FASTENERS BEING REMOVED OR LEFT IN PLACE.
3. ALL NEW ROOF SYSTEMS INCLUDING PANEL, FASTENERS, TRIM AND ACCESSORIES TO BE INSTALLED PER THAT MANUFACTURER'S STANDARDS.

Hugger Attachment (HA-03-T/R)

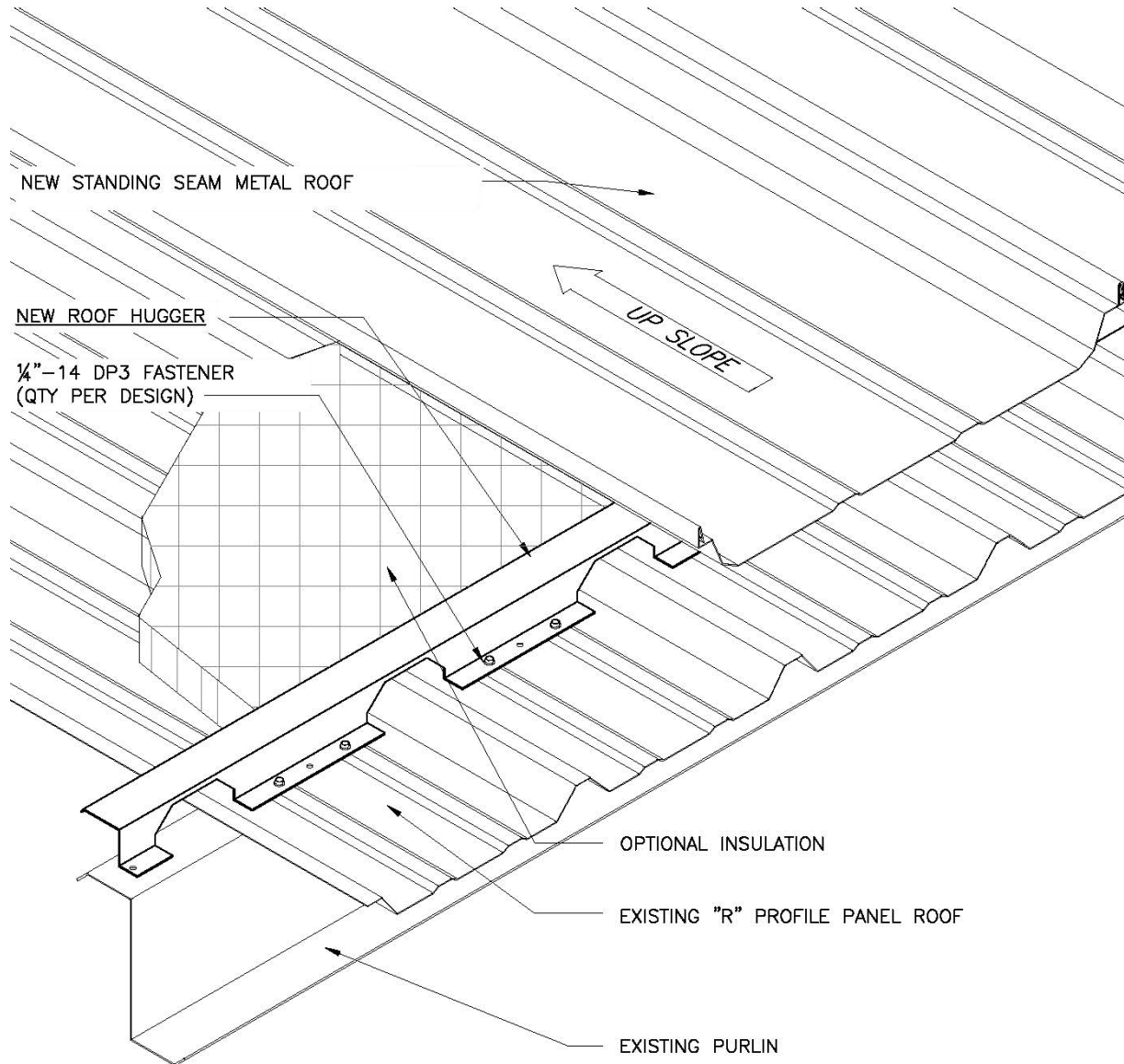
**NOTES:**

1. ALL FASTENERS NOT BY ROOF HUGGER UNLESS NOTED OTHERWISE
2. SEE ROOF HUGGER INSTALLATION INSTRUCTIONS FOR INFORMATION CONCERNING EXISTING FASTENERS BEING REMOVED OR LEFT IN PLACE.
3. ALL NEW ROOF SYSTEMS INCLUDING PANEL, FASTENERS, TRIM AND ACCESSORIES TO BE INSTALLED PER THAT MANUFACTURER'S STANDARDS.

Hugger Attachment (HA-04-T/T)

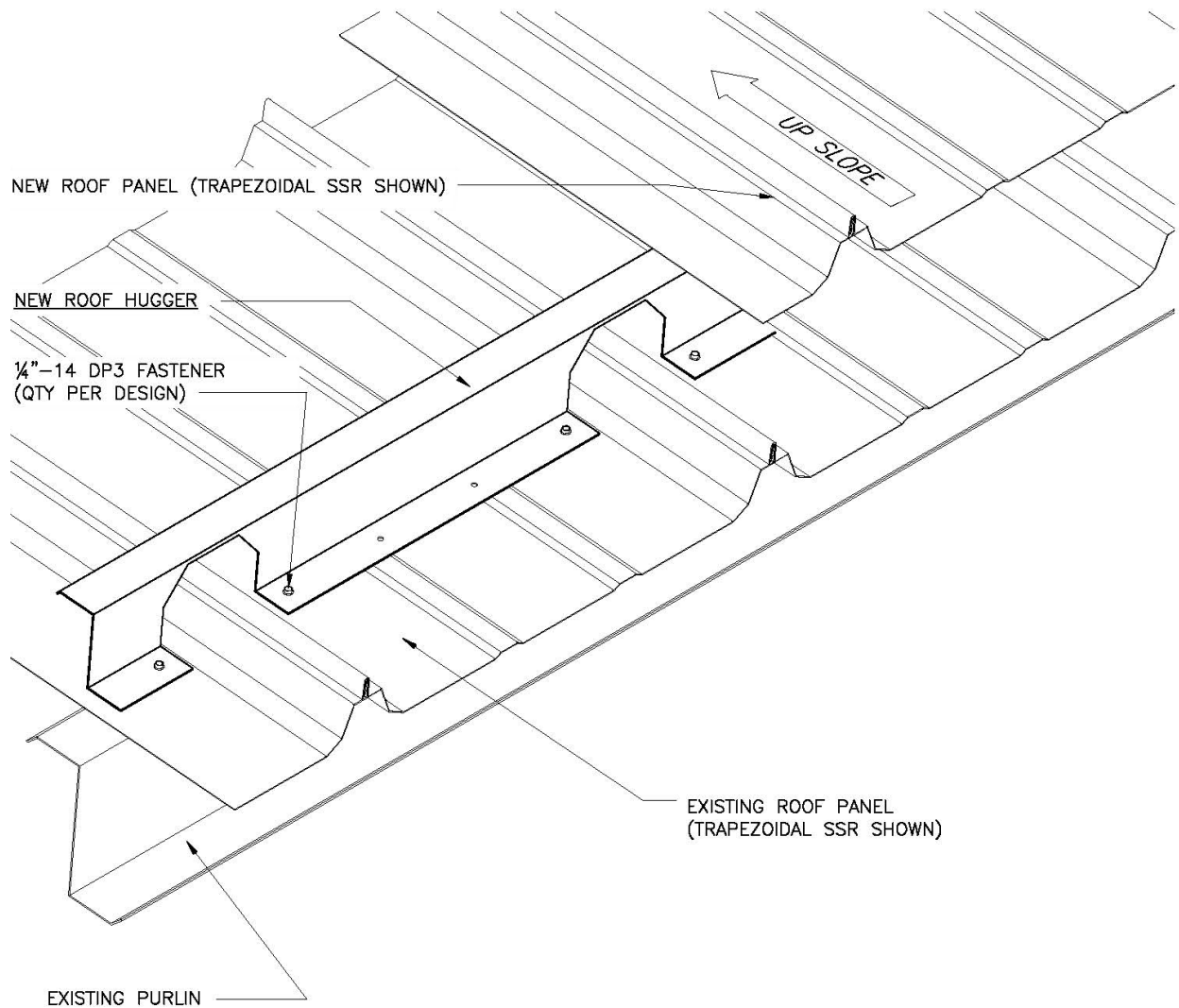
**NOTES:**

1. ALL FASTENERS NOT BY ROOF HUGGER UNLESS NOTED OTHERWISE.
2. FOR EXISTING TRAPEZOIDAL SSR WITH STAND-OFF CLIP AND THERMAL SPACER, REFER TO DETAIL SHEET HA-10-TS0.
3. ALL NEW ROOF SYSTEMS INCLUDING PANEL, FASTENERS, TRIM AND ACCESSORIES TO BE INSTALLED PER THAT MANUFACTURER'S STANDARDS.

Hugger Attachment (HA-05-T/V)

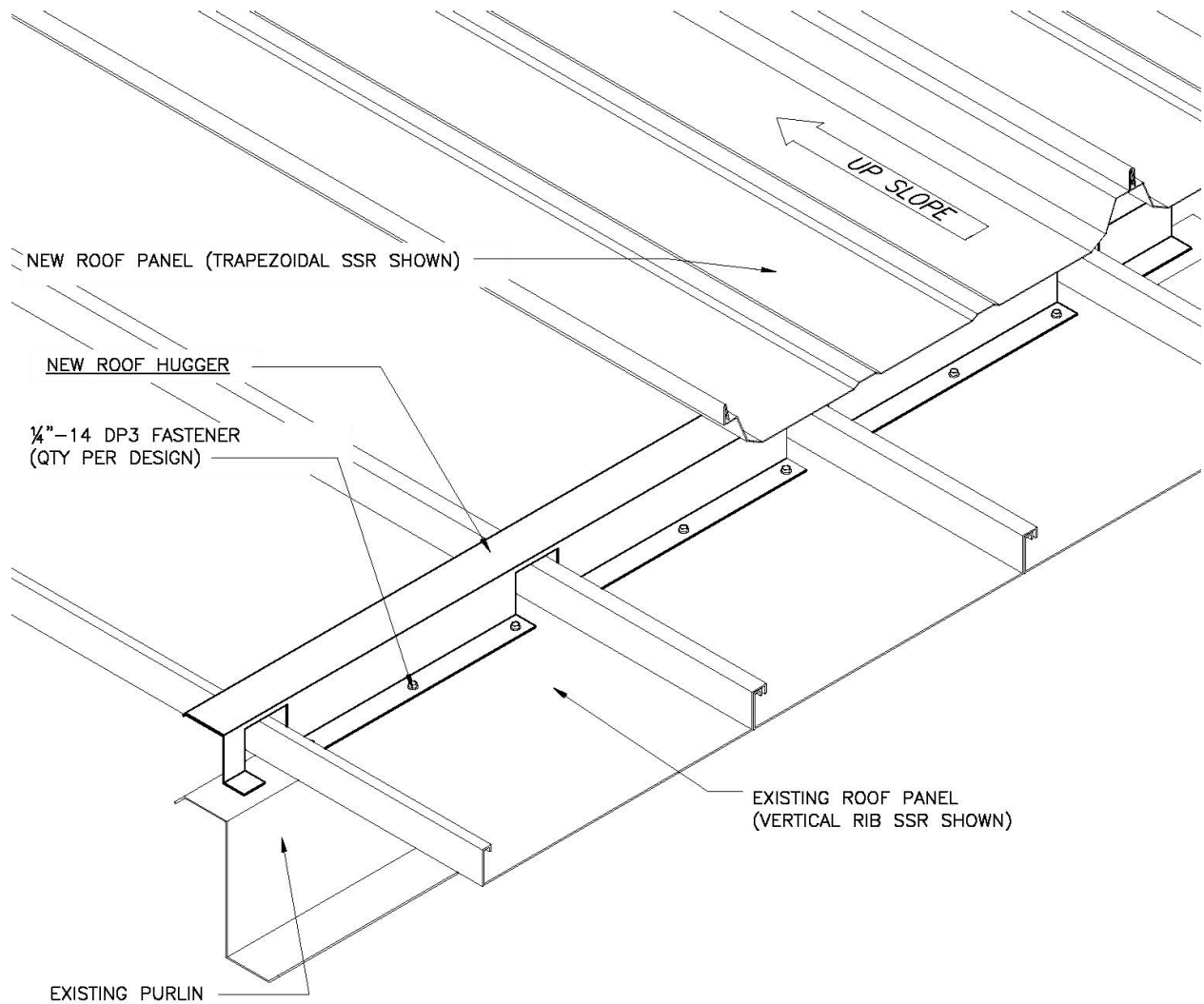

NOTES:

1. ALL FASTENERS NOT BY ROOF HUGGER UNLESS NOTED OTHERWISE
2. FOR EXISTING VERTICAL RIB SSR WITH STAND-OFF CLIP AND THERMAL SPACER, REFER TO DETAIL SHEET HA-11-VS0.
3. ALL NEW ROOF SYSTEMS INCLUDING PANEL, FASTENERS, TRIM AND ACCESSORIES TO BE INSTALLED PER THAT MANUFACTURER'S STANDARDS.

Hugger Attachment (HA-06-V/V)

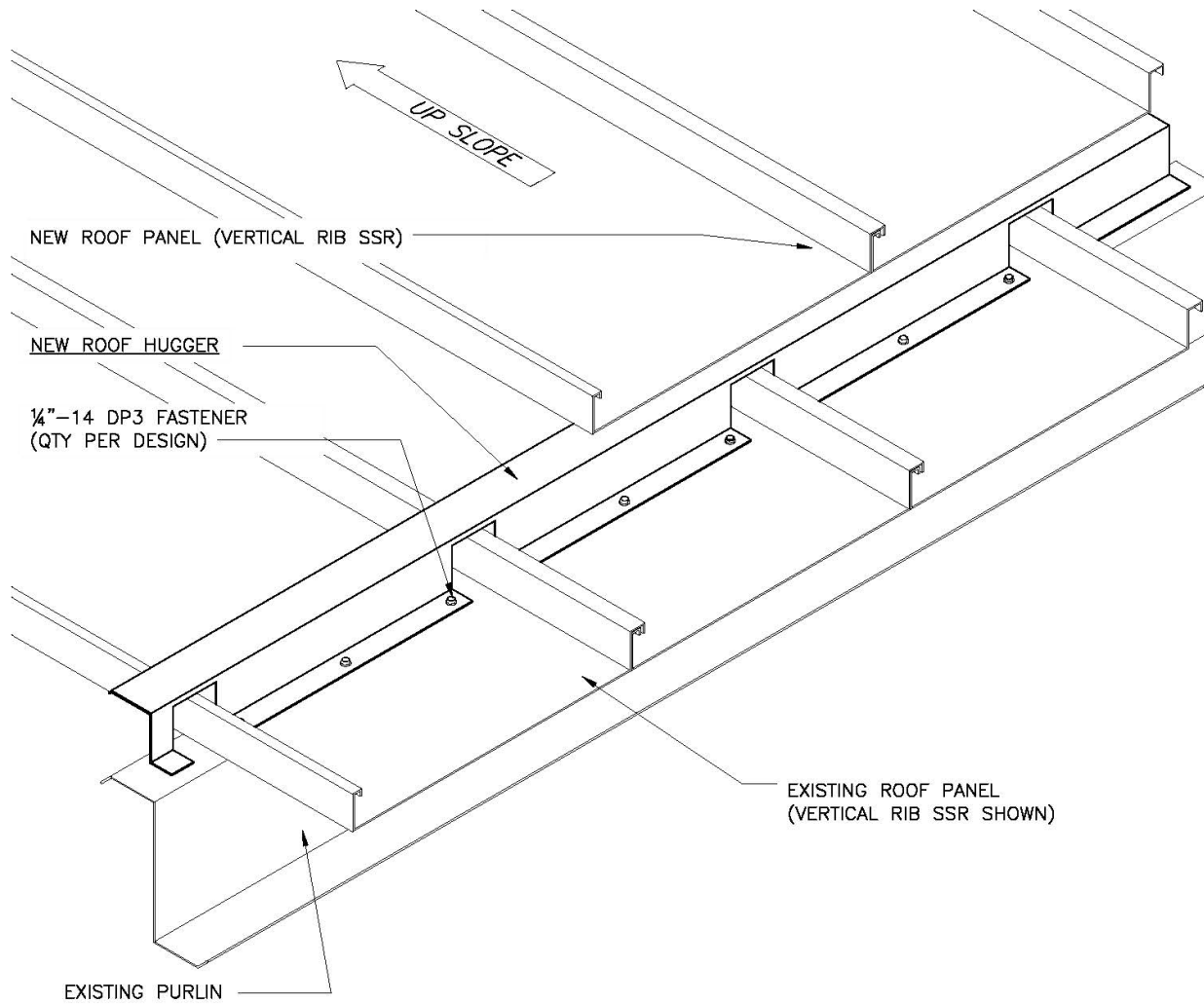

NOTES:

1. ALL FASTENERS NOT BY ROOF HUGGER UNLESS NOTED OTHERWISE
2. FOR EXISTING VERTICAL RIB SSR WITH STAND-OFF CLIP AND THERMAL SPACER, REFER TO DETAIL SHEET HA-11-VSO.
3. ALL NEW ROOF SYSTEMS INCLUDING PANEL, FASTENERS, TRIM AND ACCESSORIES TO BE INSTALLED PER THAT MANUFACTURER'S STANDARDS.

Hugger Attachment (HA-07-T/7.2)

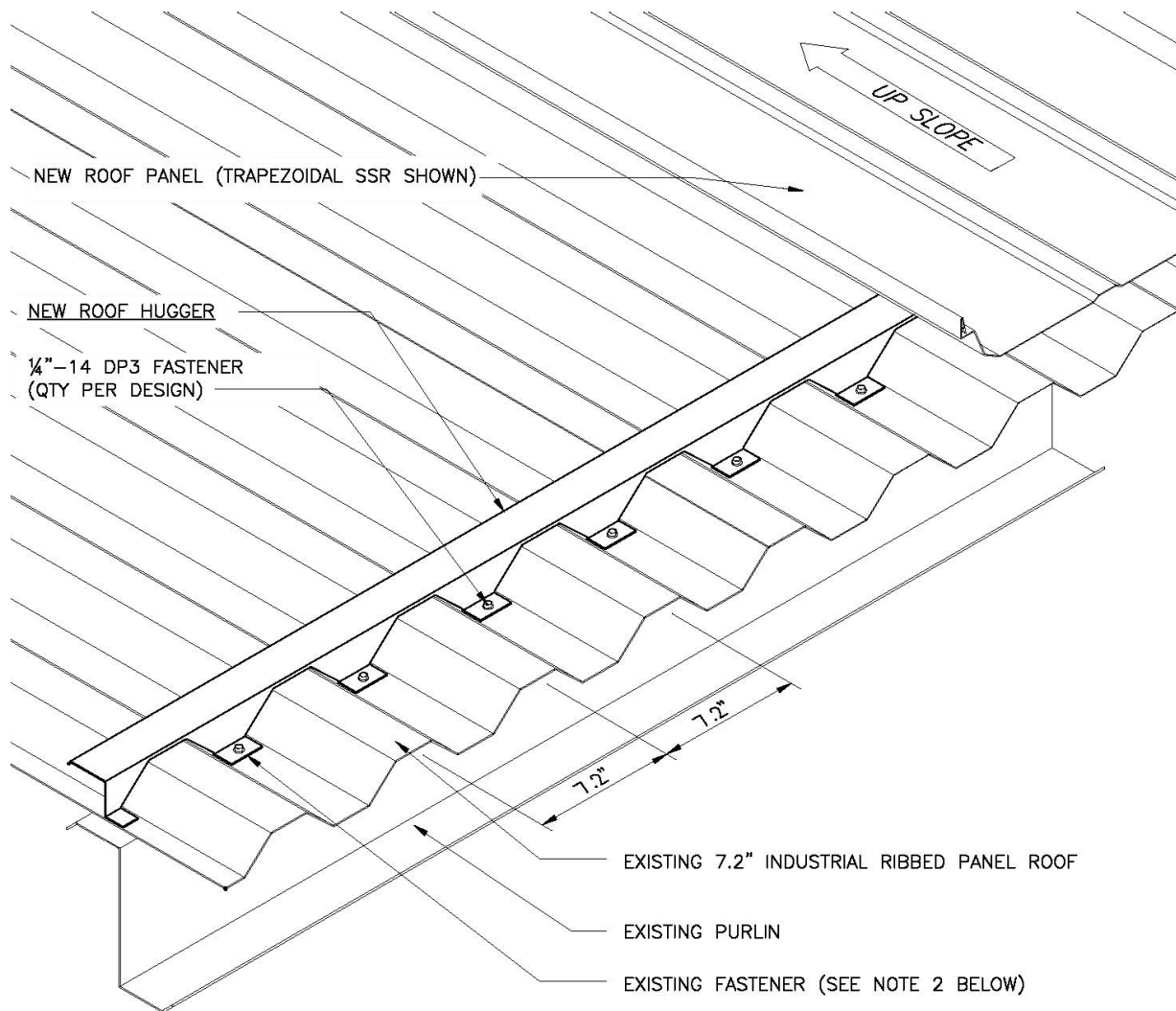

NOTES:

1. ALL FASTENERS NOT BY ROOF HUGGER UNLESS NOTED OTHERWISE
2. SEE ROOF HUGGER INSTALLATION INSTRUCTIONS FOR INFORMATION CONCERNING EXISTING FASTENERS BEING REMOVED OR LEFT IN PLACE.
3. ALL NEW ROOF SYSTEMS INCLUDING PANEL, FASTENERS, TRIM AND ACCESSORIES TO BE INSTALLED PER THAT MANUFACTURER'S STANDARDS.

Hugger Attachment (HA-08-V/T)

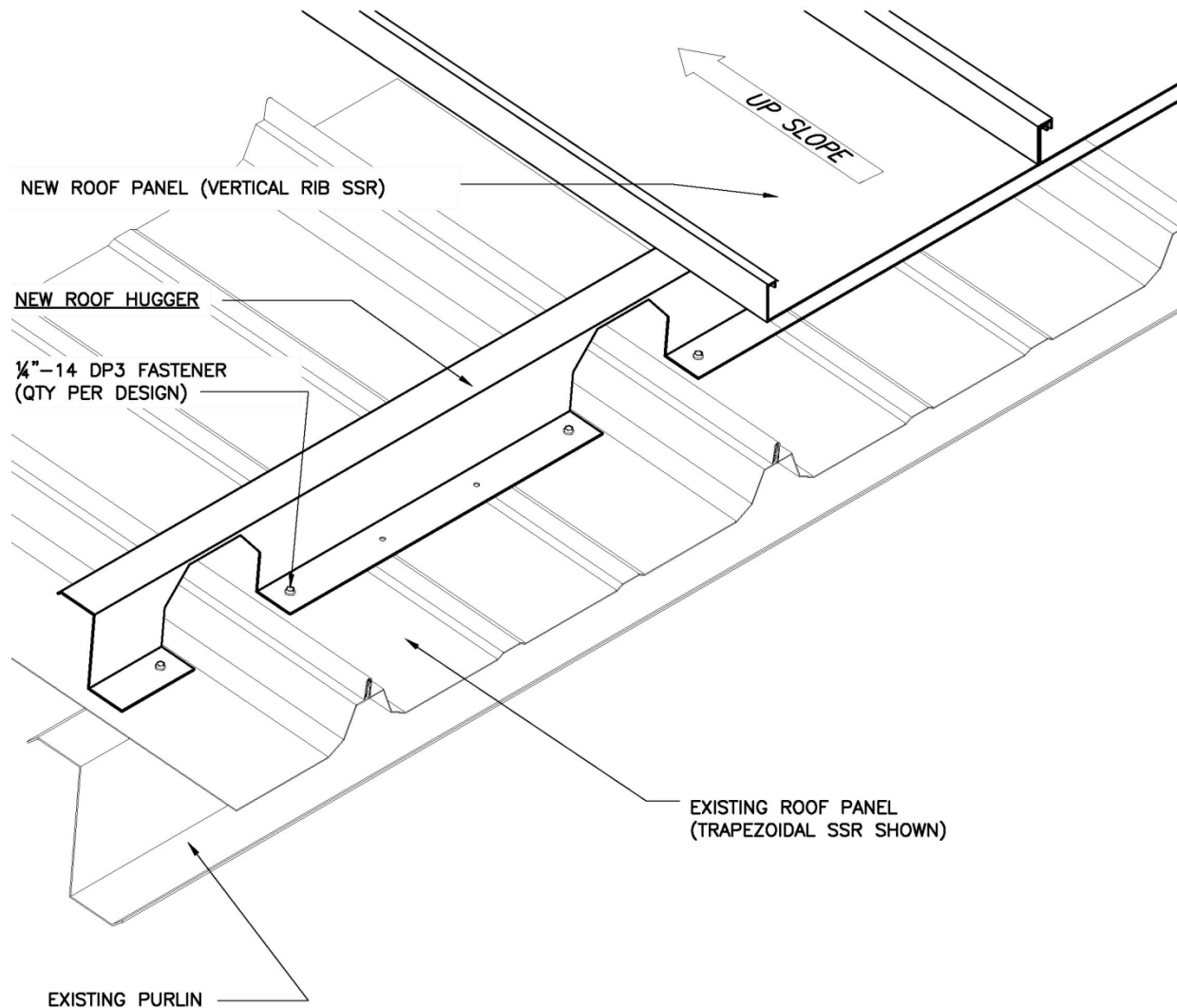
**NOTES:**

1. ALL FASTENERS NOT BY ROOF HUGGER UNLESS NOTED OTHERWISE.
2. FOR EXISTING TRAPEZOIDAL SSR WITH STAND-OFF CLIP AND THERMAL SPACER, REFER TO DETAIL SHEET HA-10-TS0.
3. ALL NEW ROOF SYSTEMS INCLUDING PANEL, FASTENERS, TRIM AND ACCESSORIES TO BE INSTALLED PER THAT MANUFACTURER'S STANDARDS.

Hugger Attachment (HA-09-T/6-10)

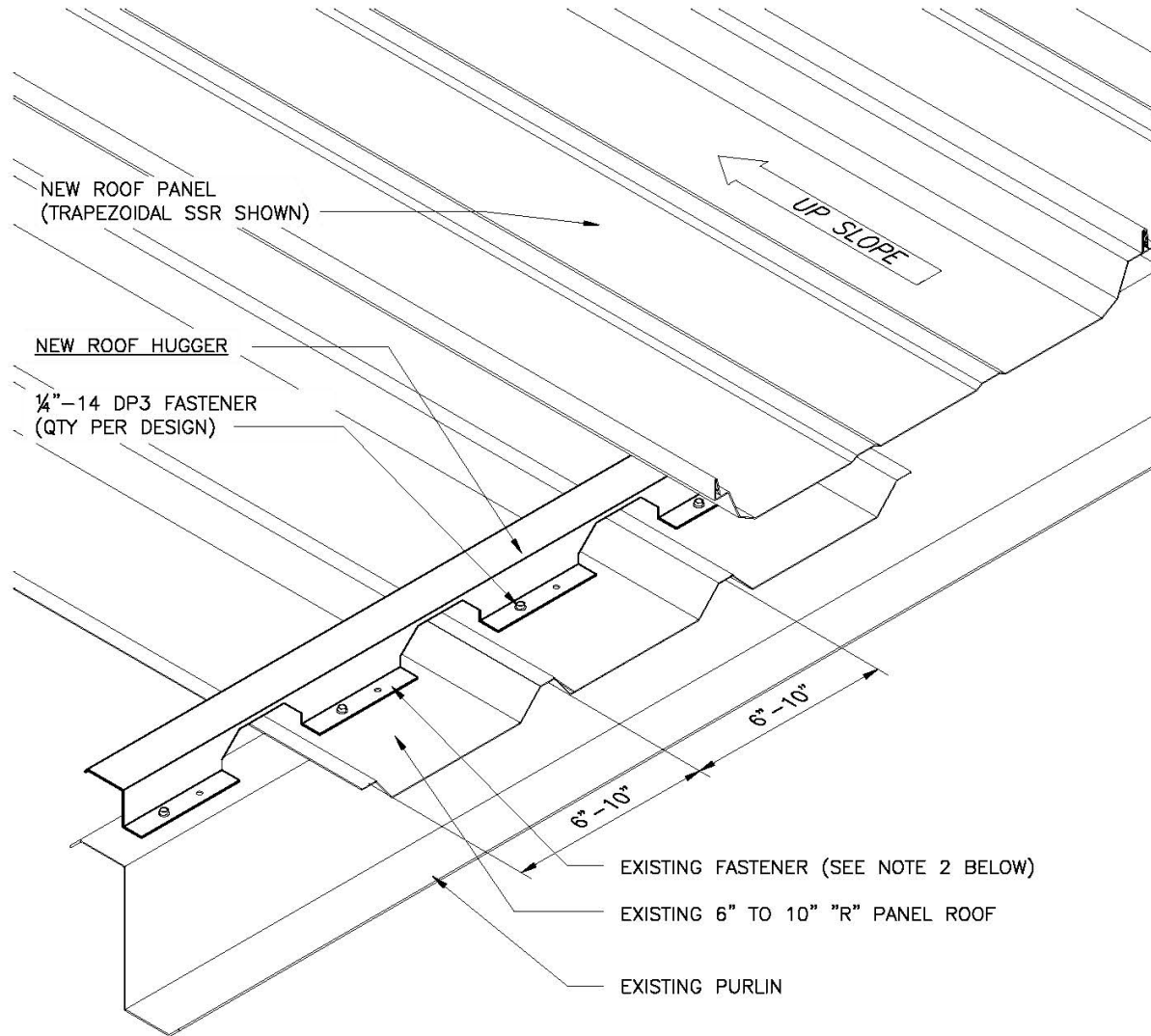

NOTES:

1. ALL FASTENERS NOT BY ROOF HUGGER UNLESS NOTED OTHERWISE
2. SEE ROOF HUGGER INSTALLATION INSTRUCTIONS FOR INFORMATION CONCERNING EXISTING FASTENERS BEING REMOVED OR LEFT IN PLACE.
3. ALL NEW ROOF SYSTEMS INCLUDING PANEL, FASTENERS, TRIM AND ACCESSORIES TO BE INSTALLED PER THAT MANUFACTURER'S STANDARDS.

Hugger Attachment (HA-10-T/TSO)

For Existing Trapezoidal SSR Roofs with Thermal Blocks and/or Stand-off Clips

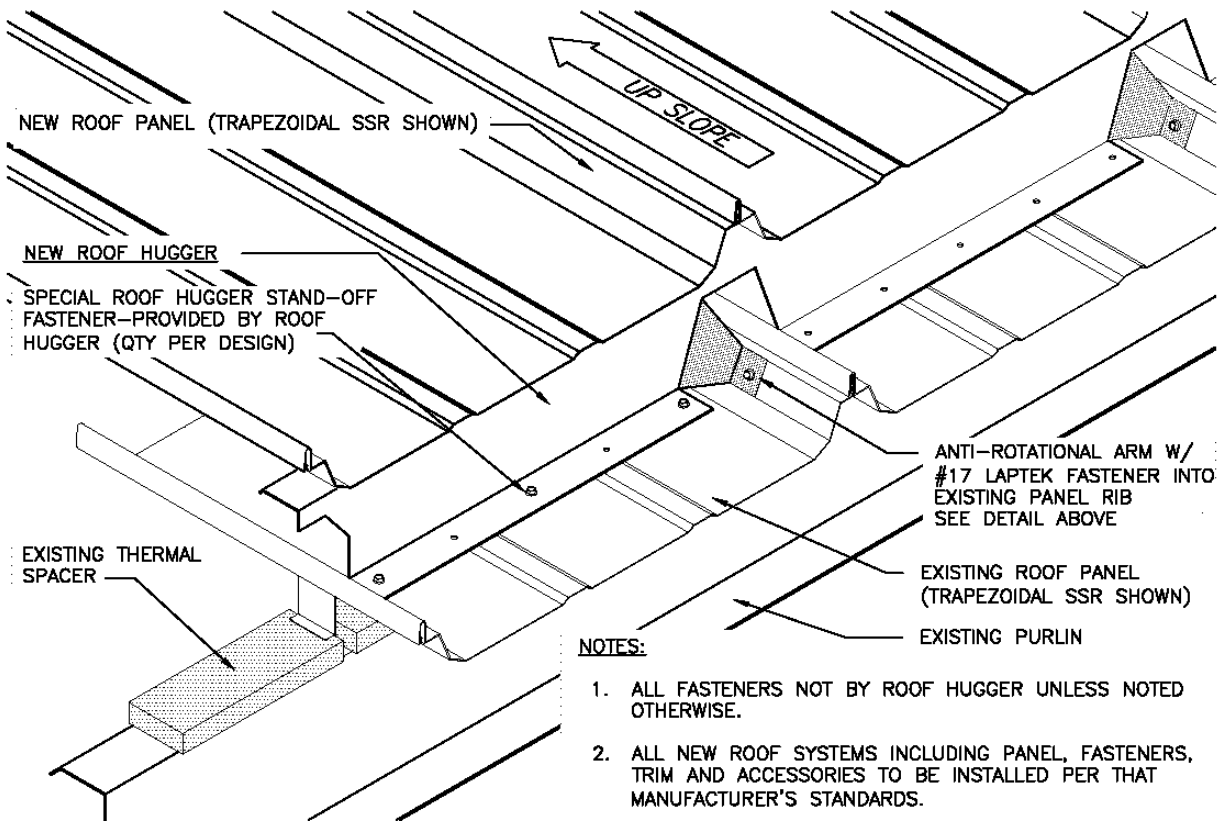
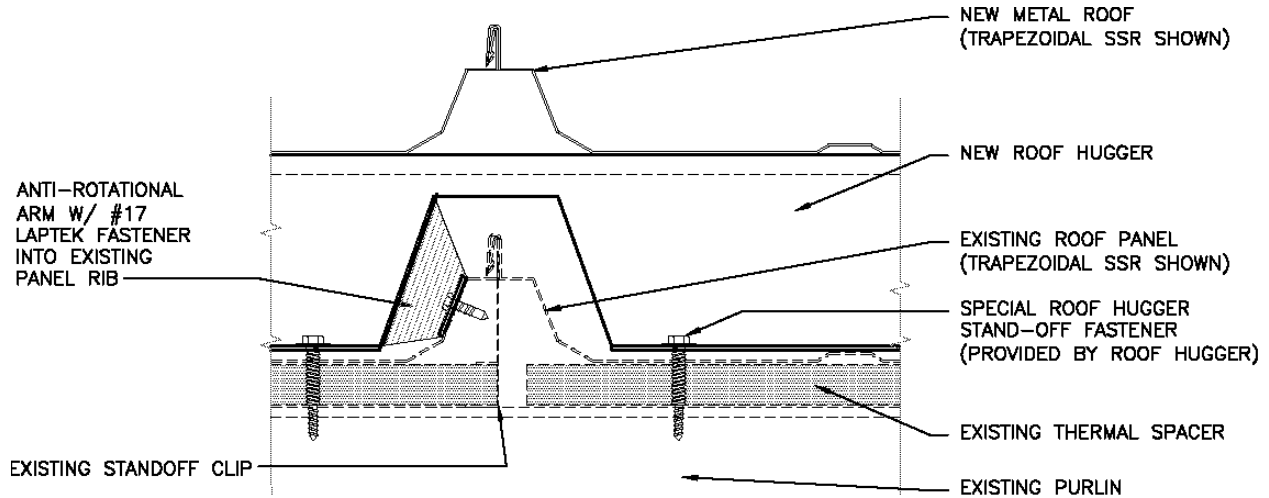

Hugger Attachment (HA-11-T/VSO)

For Existing Vertical Rib SSR Roofs with Thermal Blocks and/or Stand-off Clips

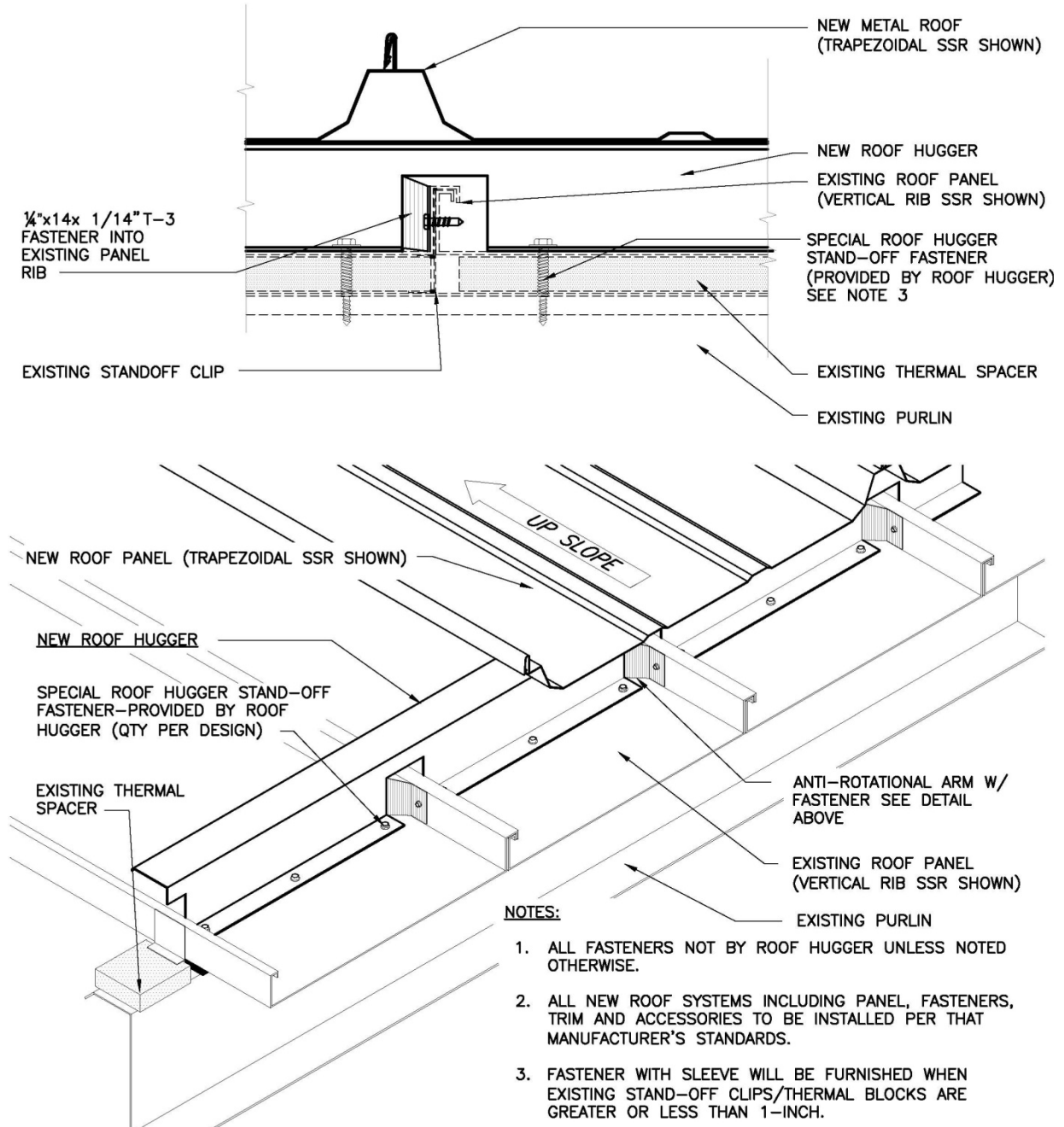

Hugger Attachment (HA-12-V/VSO)

For Existing Vertical Rib SSR Roofs with Thermal Blocks and/or Stand-off Clips

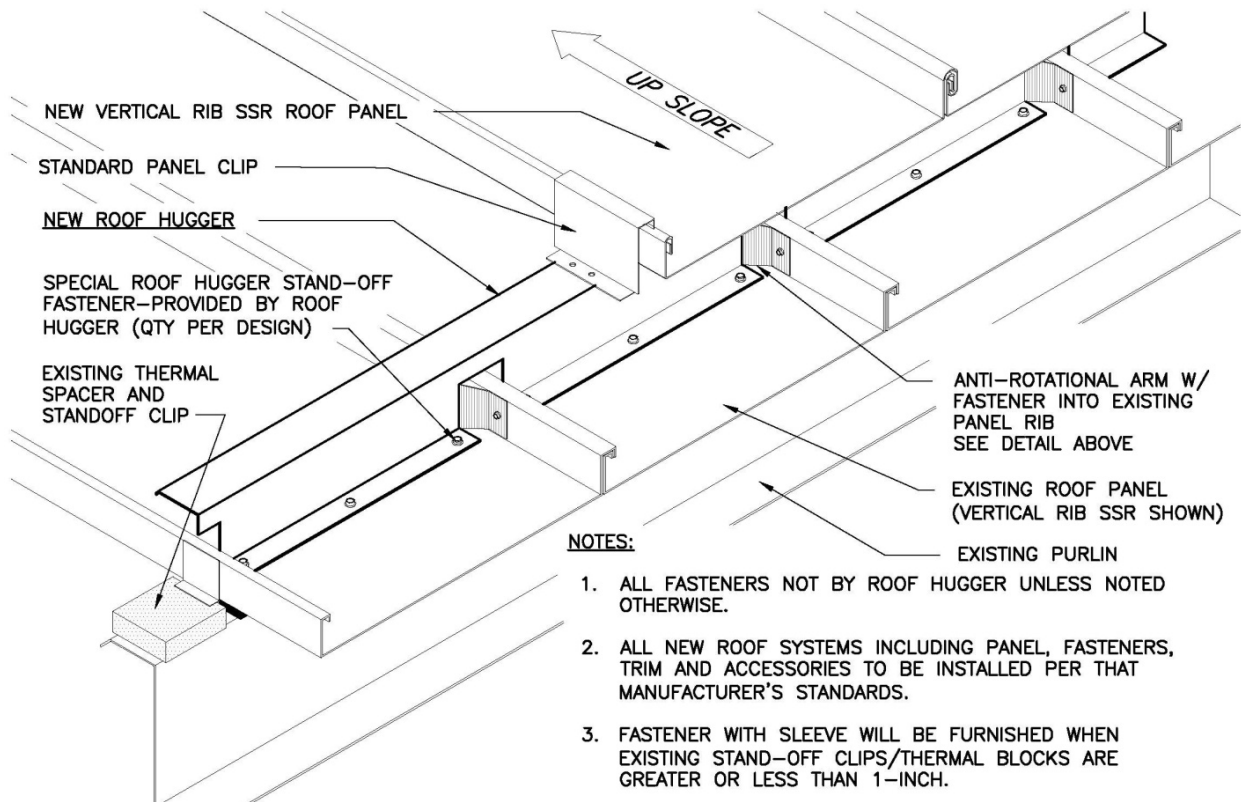
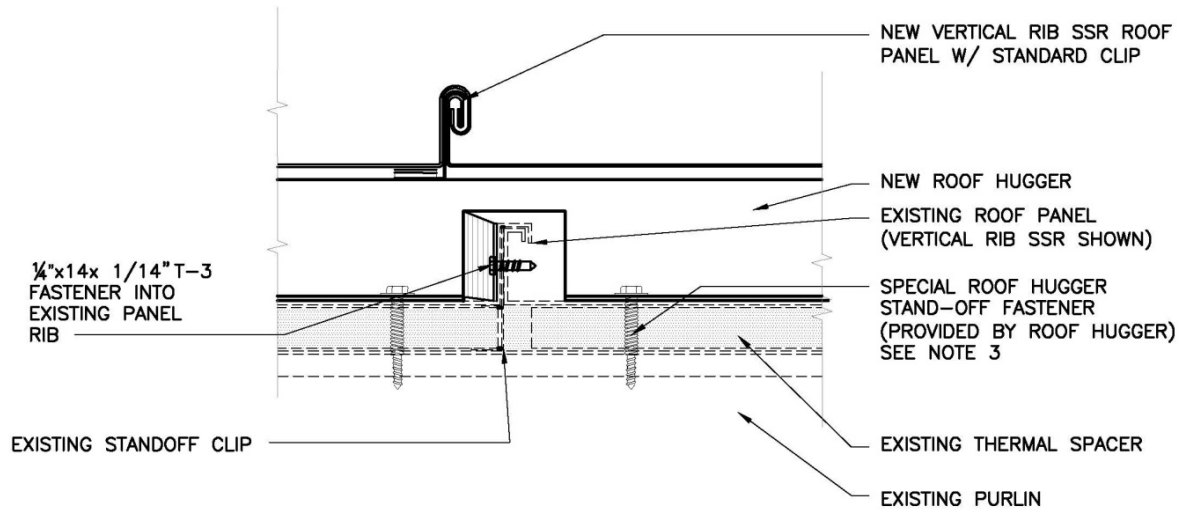

Hugger Attachment (HA-13-V/TSO)

For Existing Trapezoidal SSR Roofs with Thermal Blocks and/or Stand-off Clips

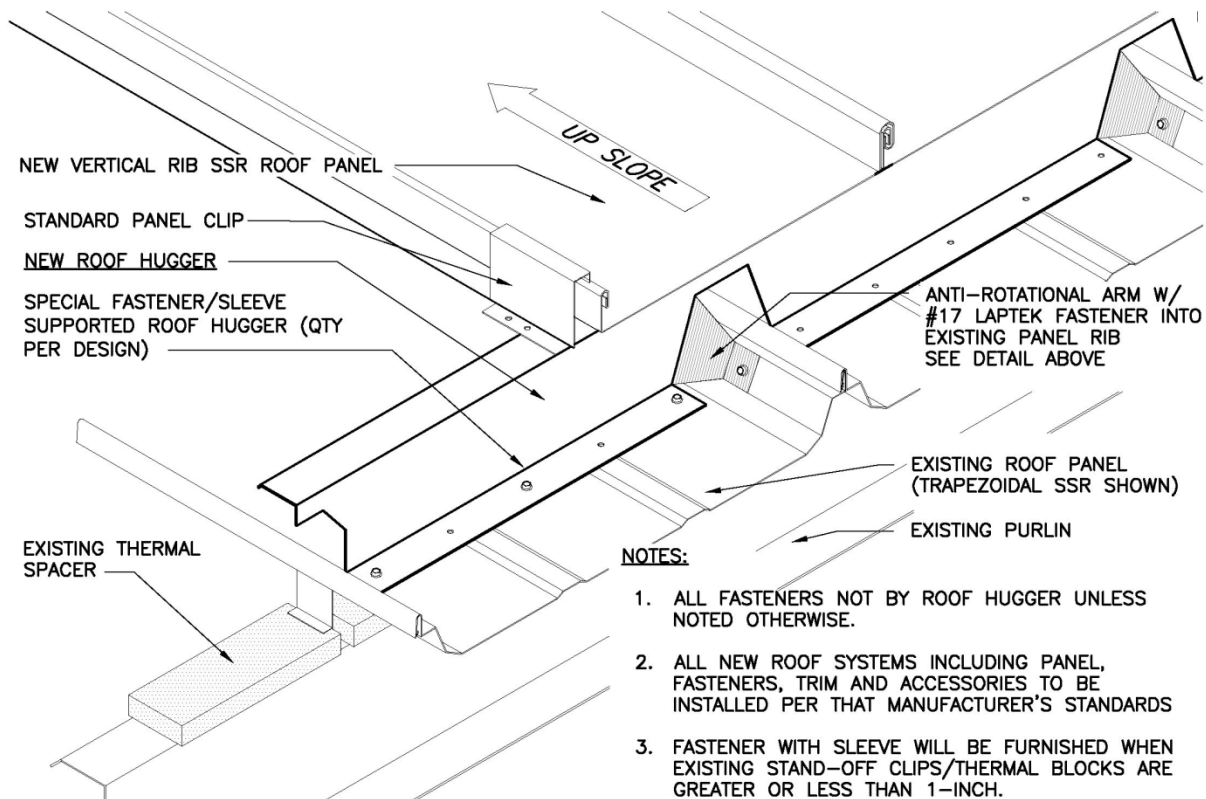
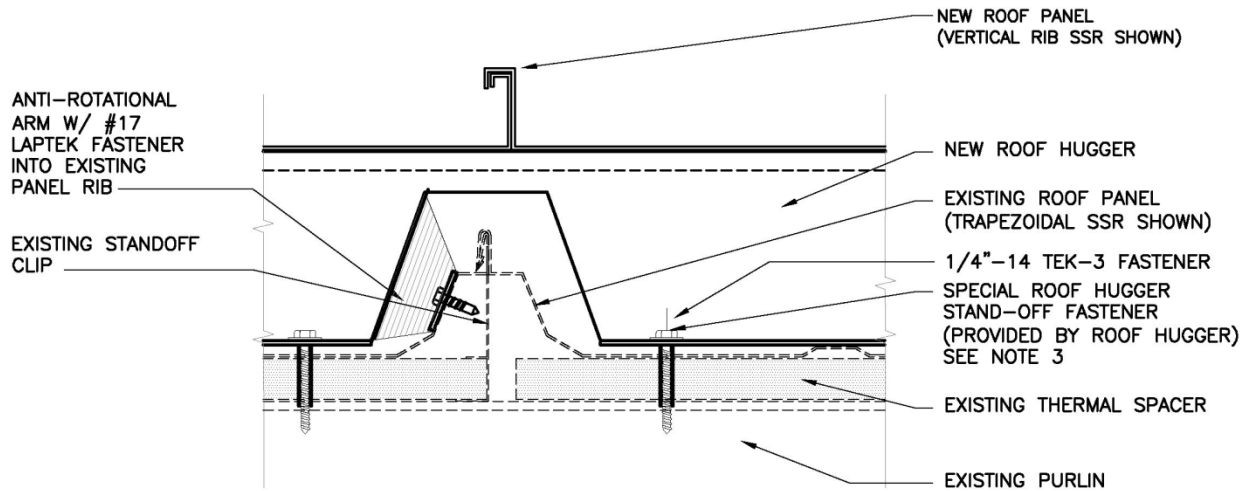

Hugger Attachment (HA-15-V/T)

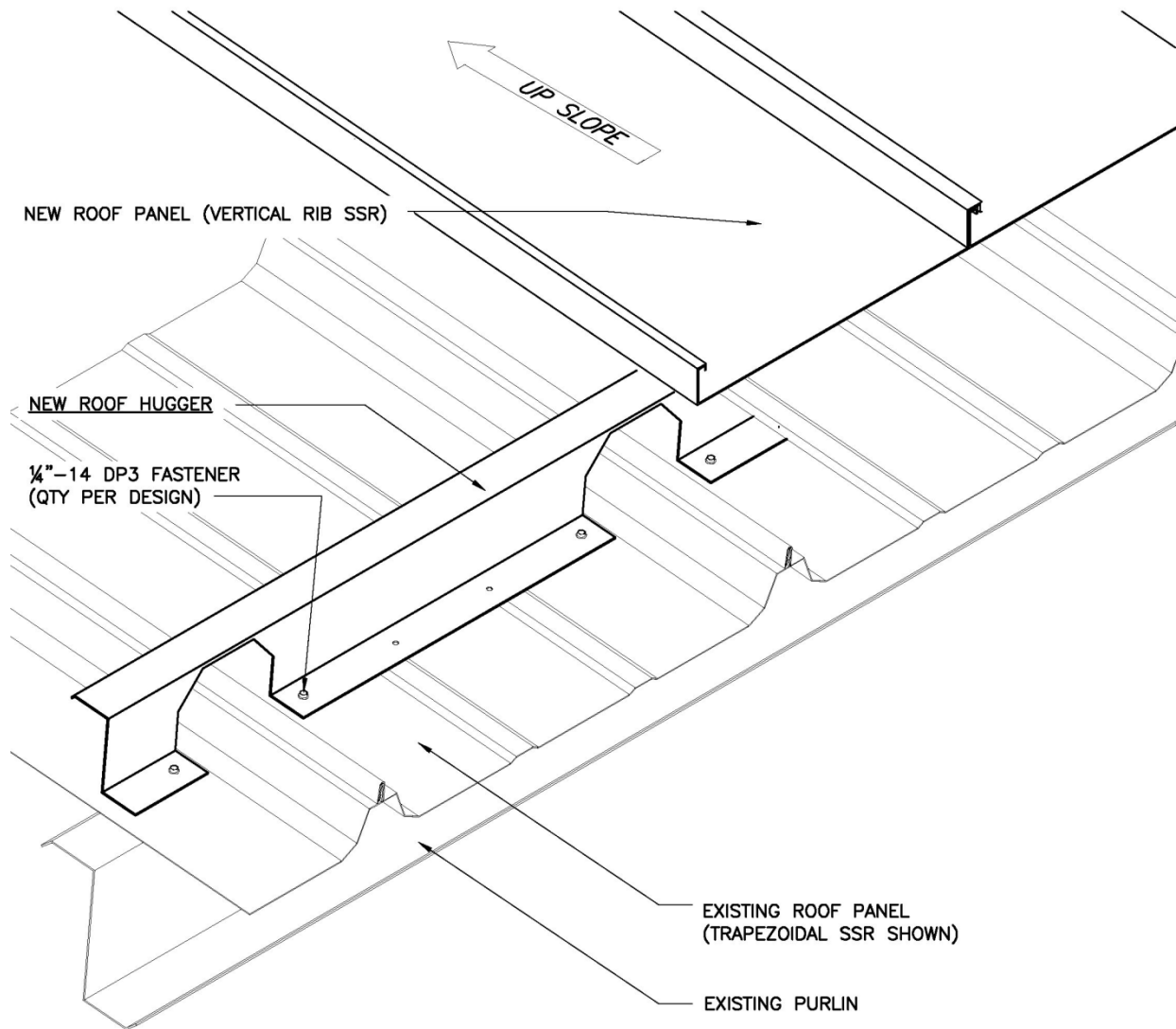

NOTES:

1. ALL FASTENERS NOT BY ROOF HUGGER UNLESS NOTED OTHERWISE.
2. FOR EXISTING TRAPEZOIDAL SSR WITH STAND-OFF CLIP AND THERMAL SPACER, REFER TO DETAIL SHEET HA-10-TS0.
3. ALL NEW ROOF SYSTEMS INCLUDING PANEL, FASTENERS, TRIM AND ACCESSORIES TO BE INSTALLED PER THAT MANUFACTURER'S STANDARDS.

Hugger Attachment (HA-16-V/R)

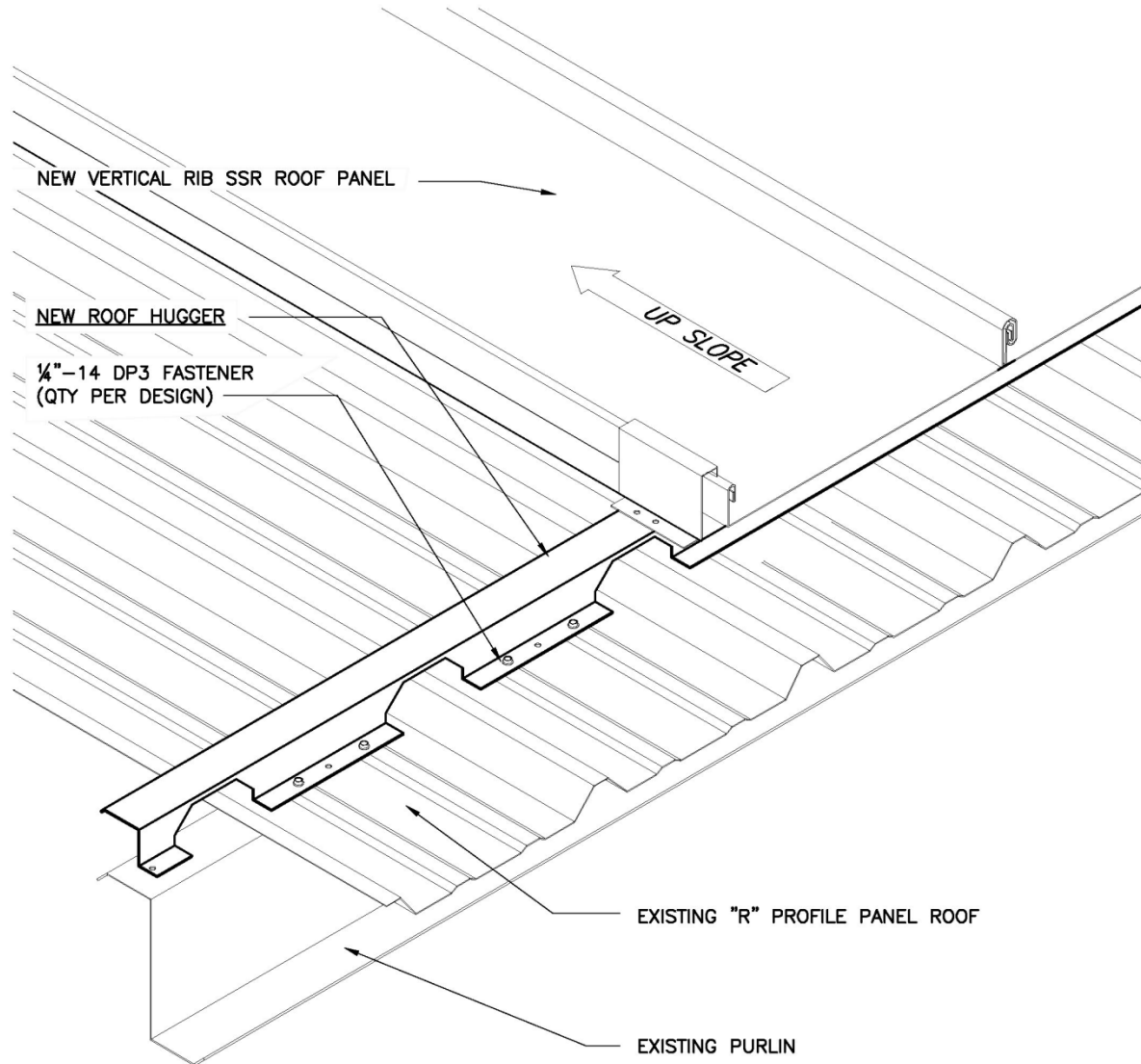
**NOTES:**

1. ALL FASTENERS NOT BY ROOF HUGGER UNLESS NOTED OTHERWISE
2. SEE ROOF HUGGER INSTALLATION INSTRUCTIONS FOR INFORMATION CONCERNING EXISTING FASTENERS BEING REMOVED OR LEFT IN PLACE.
3. ALL NEW ROOF SYSTEMS INCLUDING PANEL, FASTENERS, TRIM AND ACCESSORIES TO BE INSTALLED PER THAT MANUFACTURER'S STANDARDS.

Hugger Attachment – Corru-Fit™

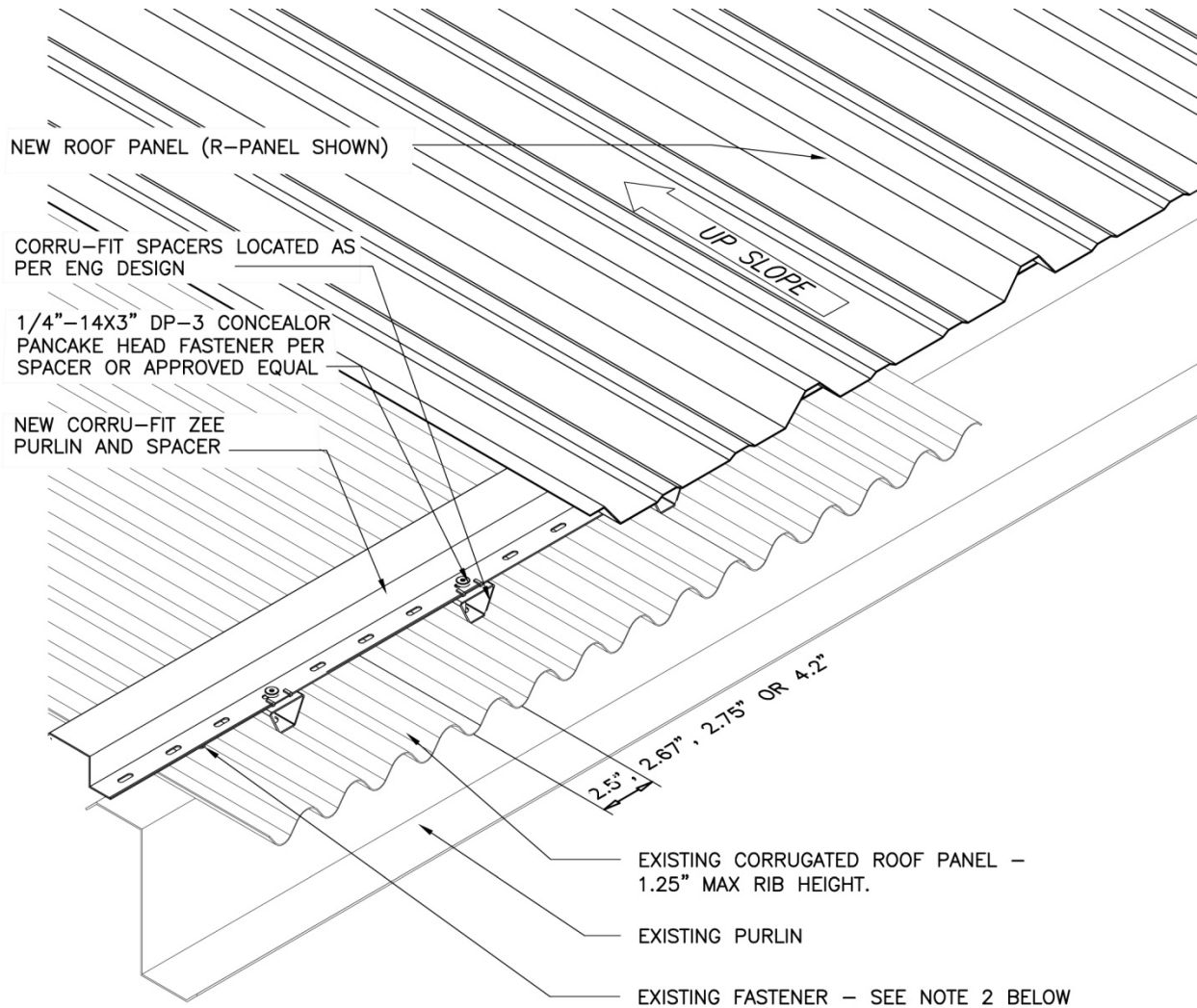

NOTE: We no longer utilize our factory-notched sub-purlins for existing sine-wave corrugated roofs due to their inherent inconsistent corrugation spacing. However, please refer to Our new **Corru-Fit™** product Design Guide for more details and information on this Product. Available on our website at www.roofhugger.com or by requesting information from sales@roofhugger.com

Panel End Lap (EL-02-G)

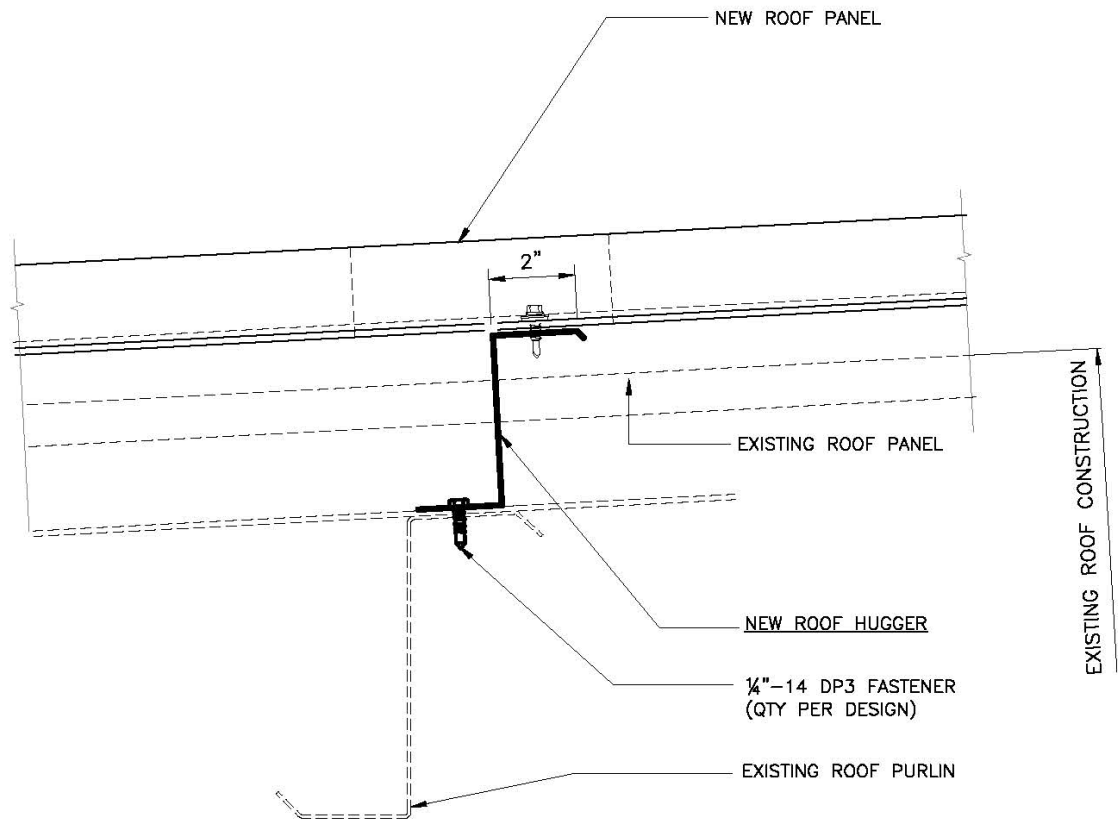
**NOTES:**

1. ALL FASTENERS NOT BY ROOF HUGGER UNLESS NOTED OTHERWISE
2. SPECIAL ENDLAP HUGGER REQUIRED IF MORE THAN 2" FLANGE IS REQUIRED
(OPTION: SPECIAL ROOF HUGGER CAN BE PROVIDED IF A MINIMUM OF 2 1/2"-4" IS REQUIRED).
3. ALL NEW ROOF SYSTEMS INCLUDING PANEL, FASTENERS, TRIM AND ACCESSORIES TO BE INSTALLED PER THAT MANUFACTURER'S STANDARDS.

Hugger Lap (HL-01-R)

Huggers for All Gauge Purlins over 12" O.C. "R" Panels

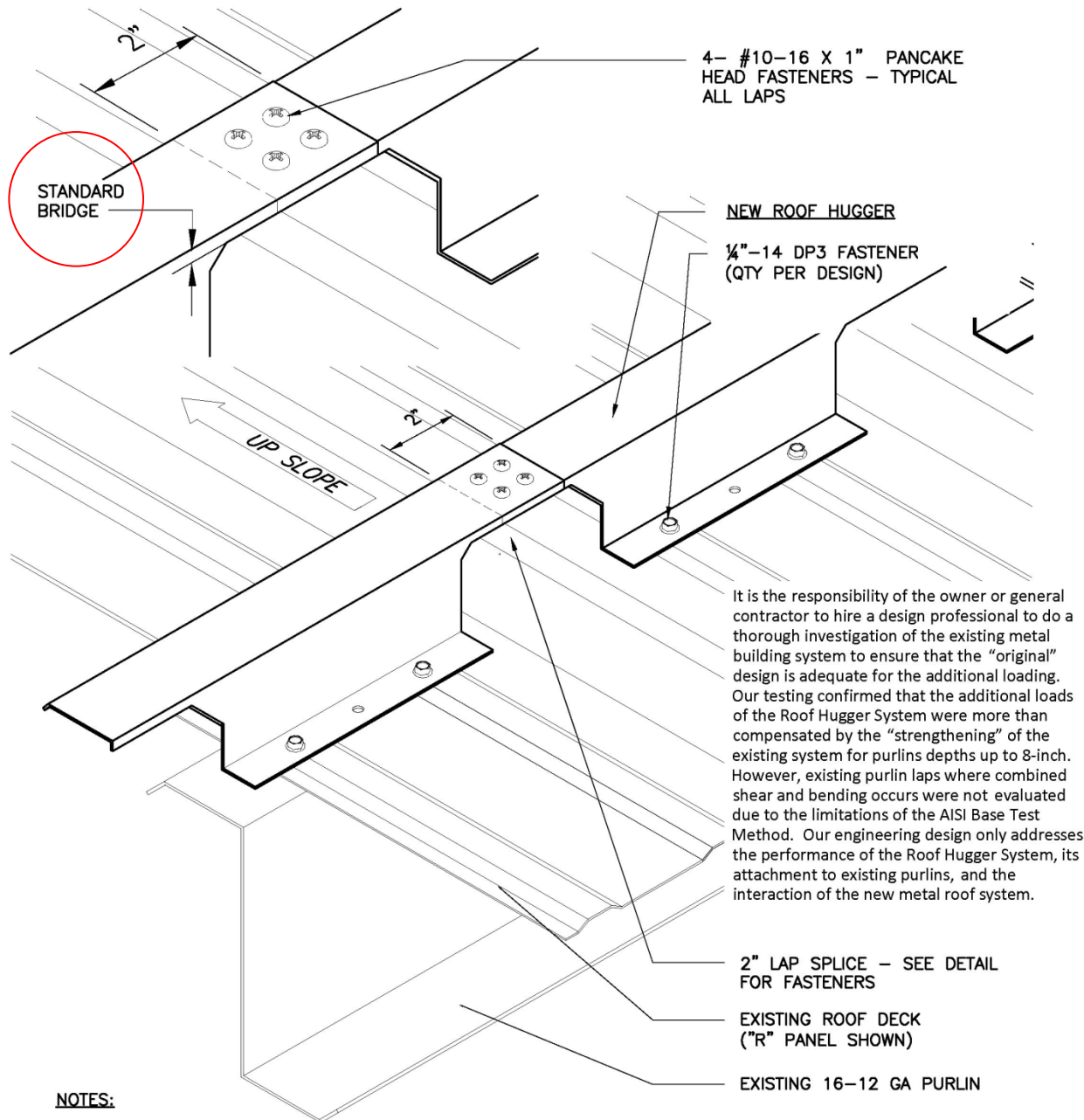

NOTES:

1. ALL FASTENERS NOT BY ROOF HUGGER UNLESS NOTED OTHERWISE

Hugger Lap (HL-02-R/16-14)

Special Huggers for 16 or 14-Gauge Purlins over Ribbed Panels

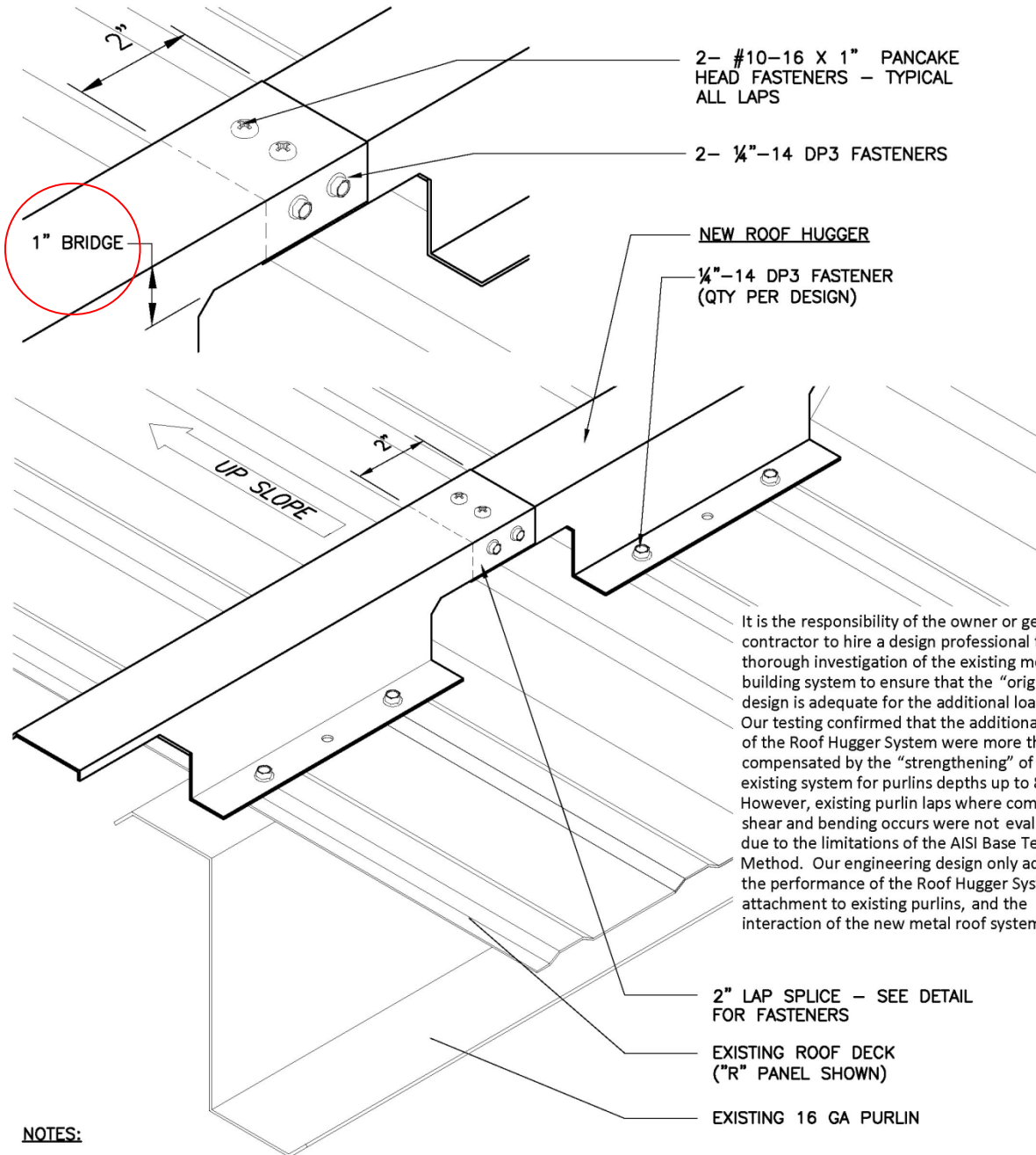

NOTES:

1. ALL FASTENERS NOT BY ROOF HUGGER UNLESS NOTED OTHERWISE

Hugger Lap (HL-03-R/12)

Special Huggers for 12-Gauge Purlins over Ribbed Panels

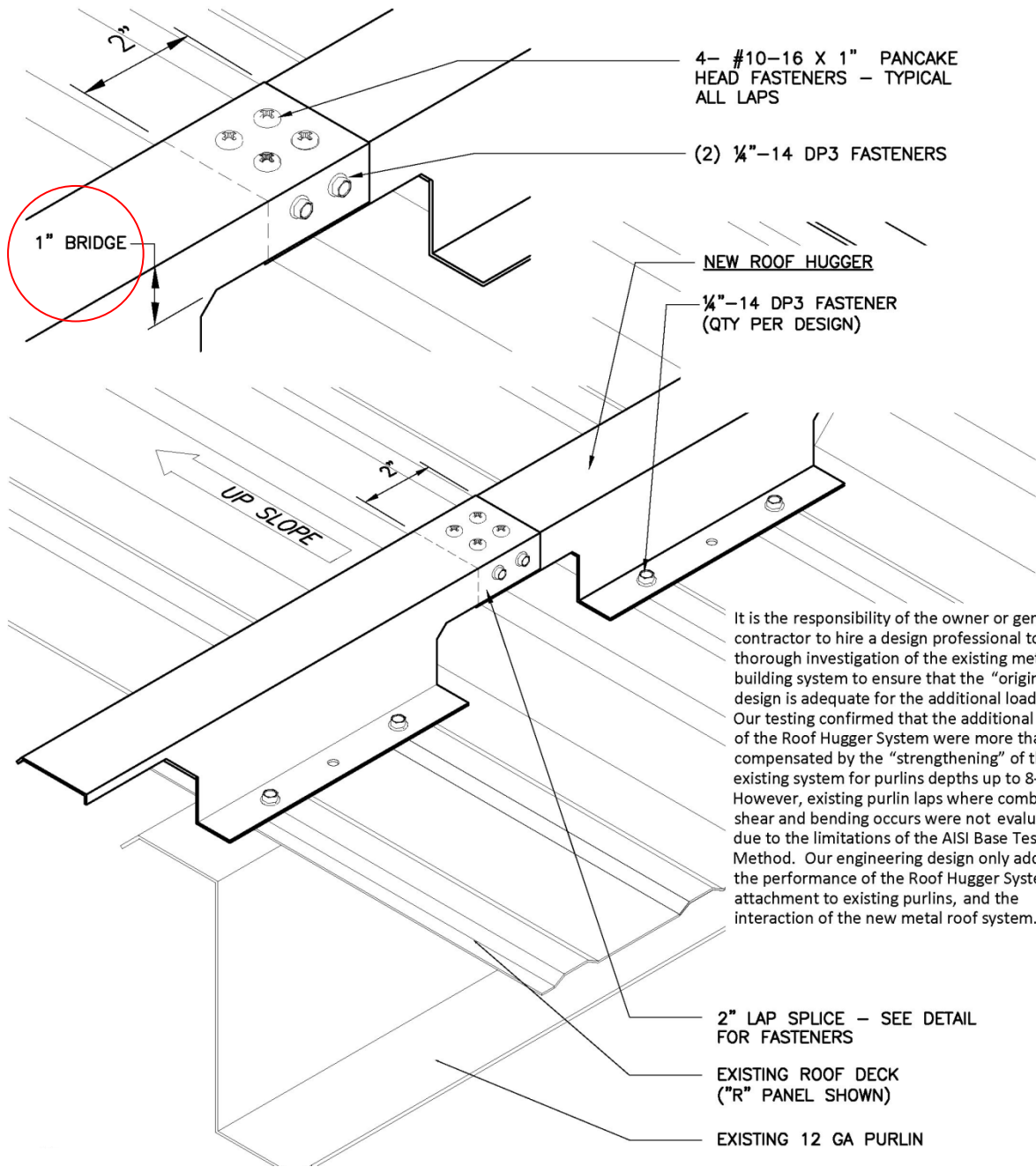

It is the responsibility of the owner or general contractor to hire a design professional to do a thorough investigation of the existing metal building system to ensure that the "original" design is adequate for the additional loading. Our testing confirmed that the additional loads of the Roof Hugger System were more than compensated by the "strengthening" of the existing system for purlins depths up to 8-inch. However, existing purlin laps where combined shear and bending occurs were not evaluated due to the limitations of the AISI Base Test Method. Our engineering design only addresses the performance of the Roof Hugger System, its attachment to existing purlins, and the interaction of the new metal roof system.

Hugger Lap (HL-04-V)

Vertical Rib SSR Hugger Lap over All Gauge Purlins

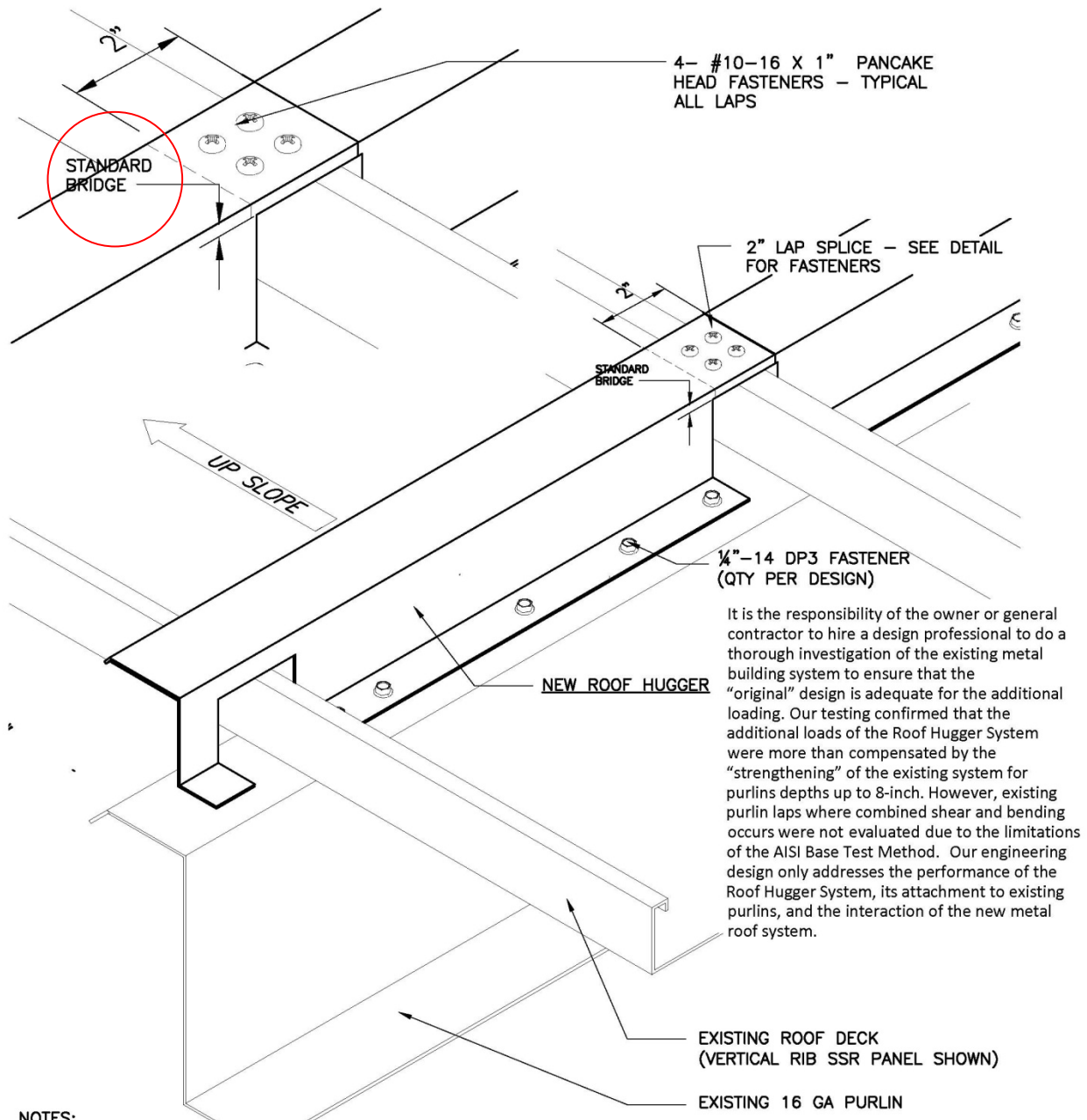

NOTES:

1. ALL FASTENERS NOT BY ROOF HUGGER UNLESS NOTED OTHERWISE

Hugger Lap (HL-05-T)

Trapezoidal SSR Hugger Lap over All Gauge Purlins

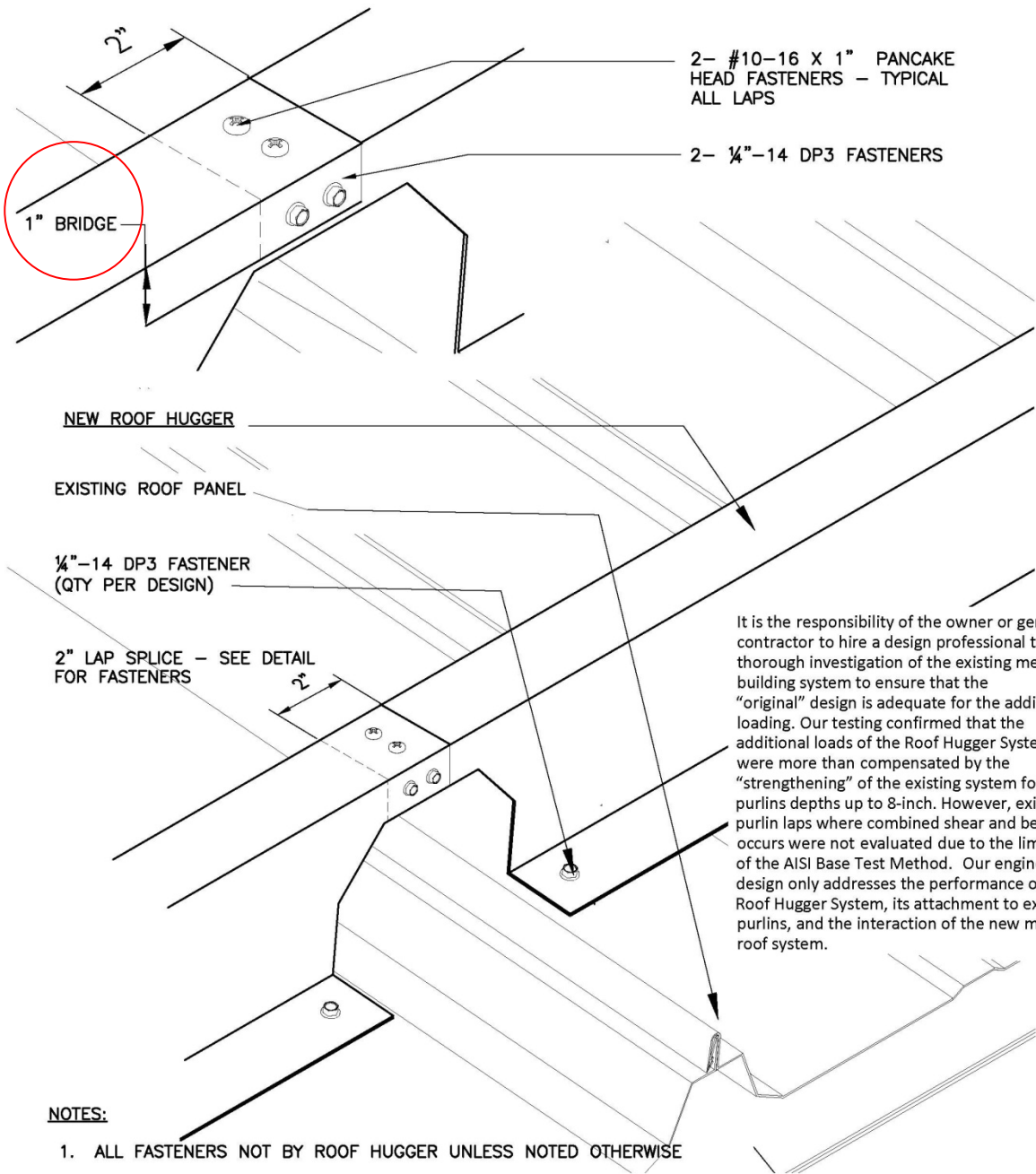

Corner/Edge Zone Framing (ZF-01-R)

Integral Corner & Edge Zone Framing Over Ribbed Panel Roofs

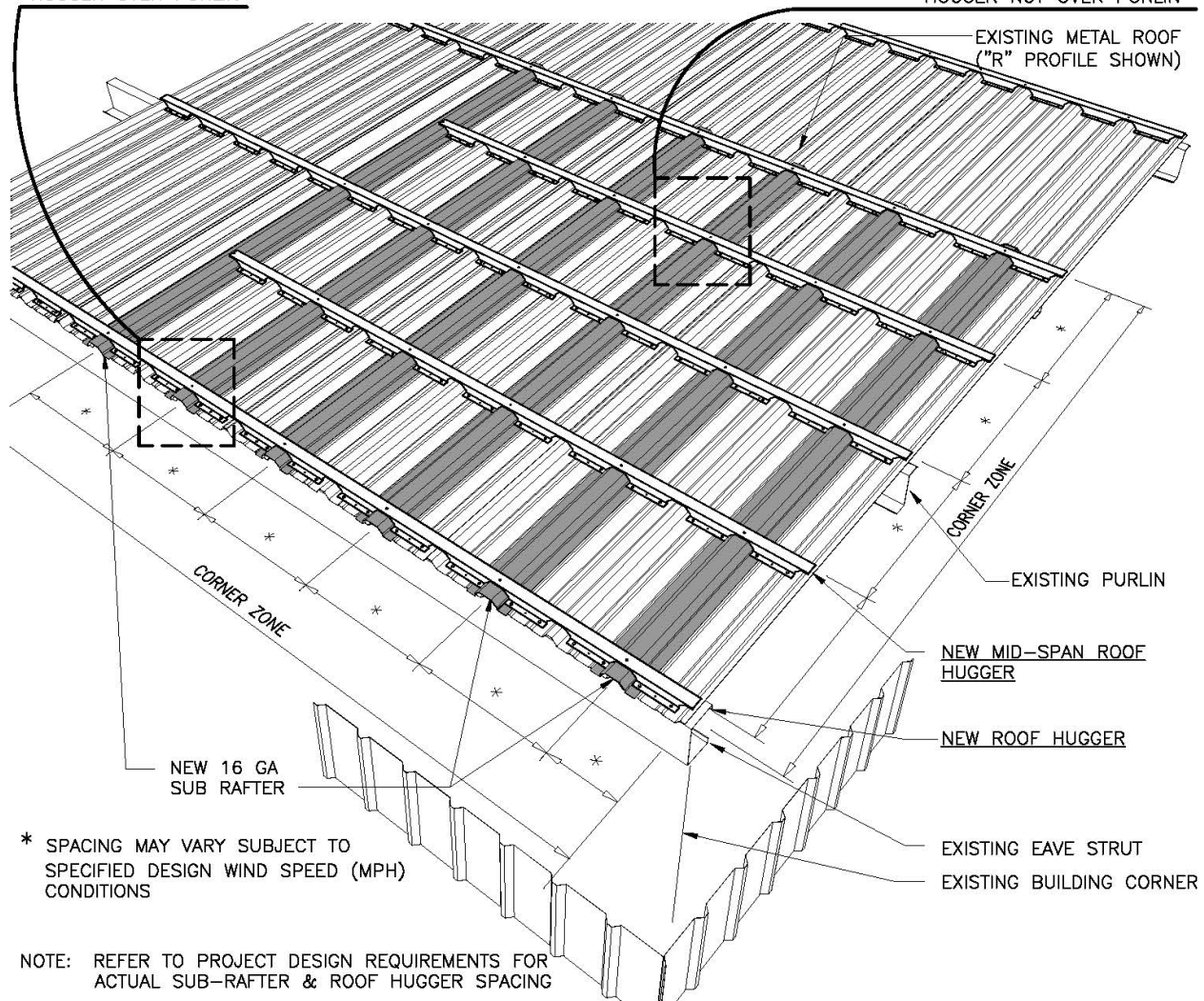
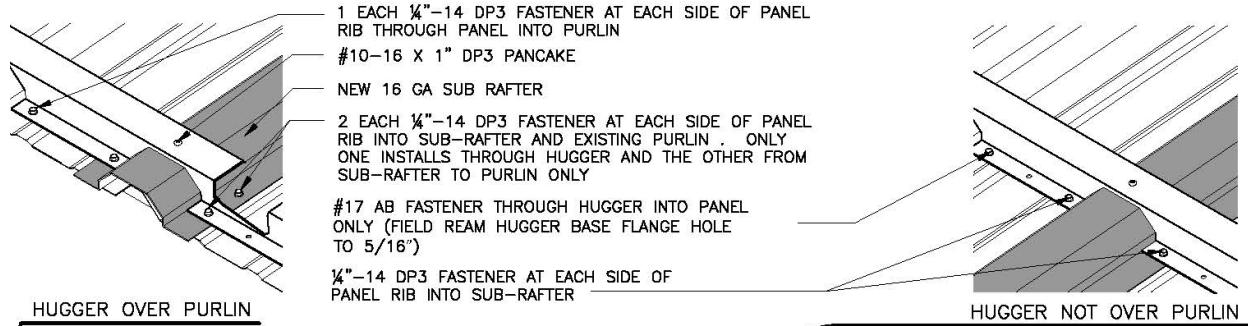

* SPACING MAY VARY SUBJECT TO SPECIFIED DESIGN WIND SPEED (MPH) CONDITIONS

NOTE: REFER TO PROJECT DESIGN REQUIREMENTS FOR ACTUAL SUB-RAFTER & ROOF HUGGER SPACING

Corner/Edge Zone Framing (ZF-03-V)

Integral Corner & Edge Zone Framing Over Vertical Rib SSR Roofs

Note: ZF-02-T currently not available

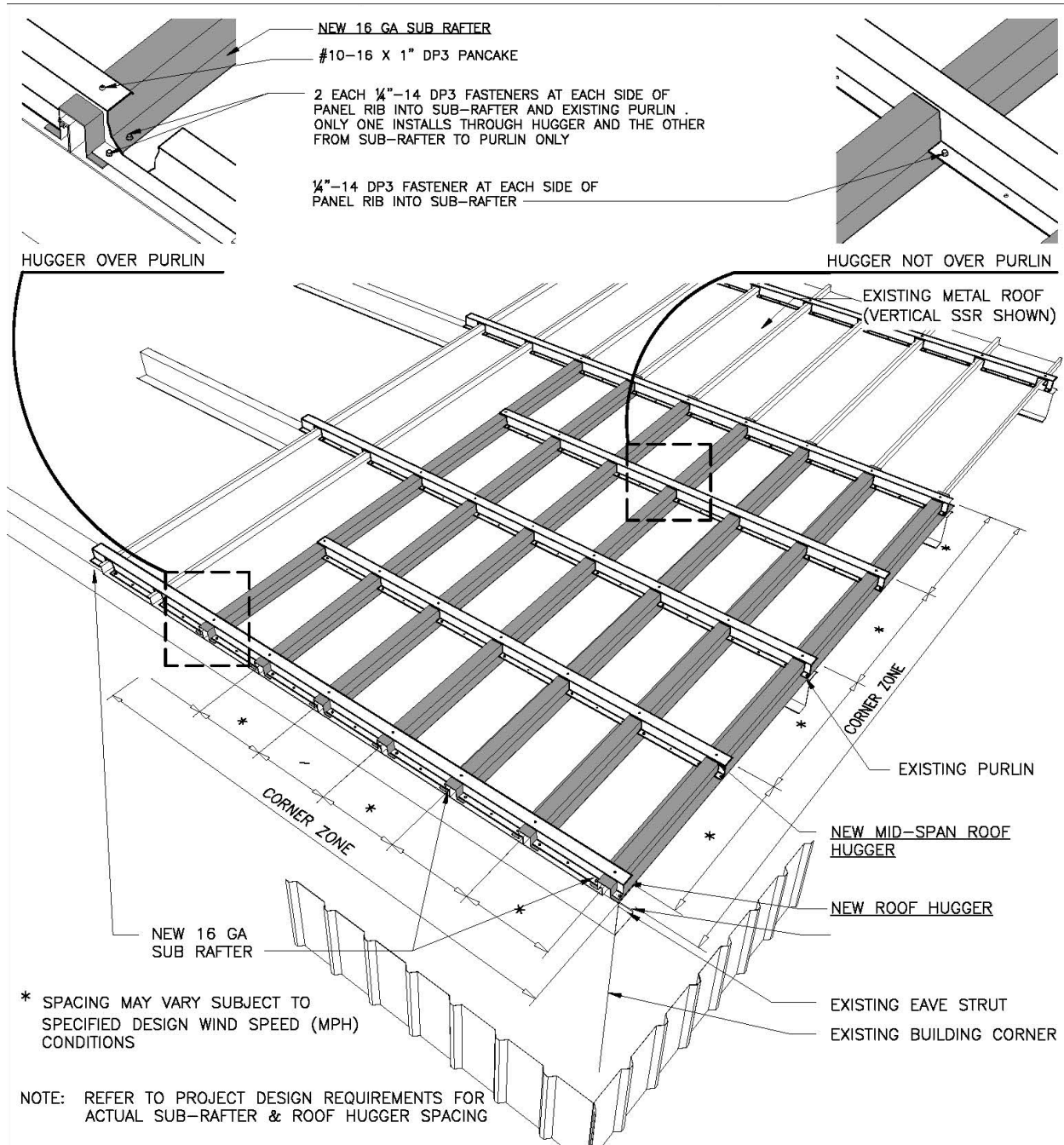

Corner/Edge Zone Framing (ZF-04-HAT-T)

Corner & Edge Zone "Hat Grid" Framing Over Trapezoidal SSR

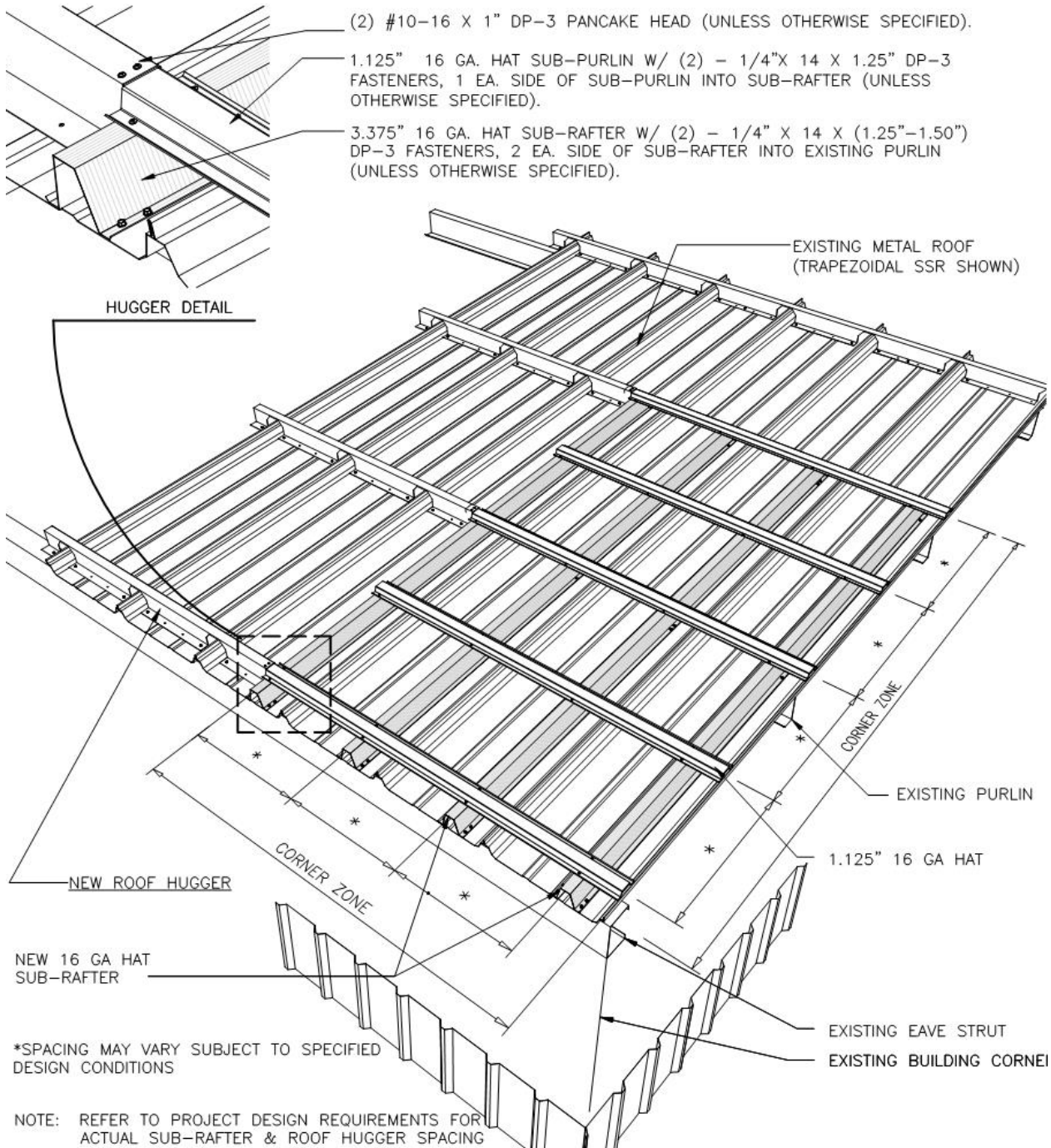

Corner/Edge Zone Framing (ZF-05-HAT-R)

Corner & Edge Zone "Hat Grid" Framing Over R-Panel Roofs

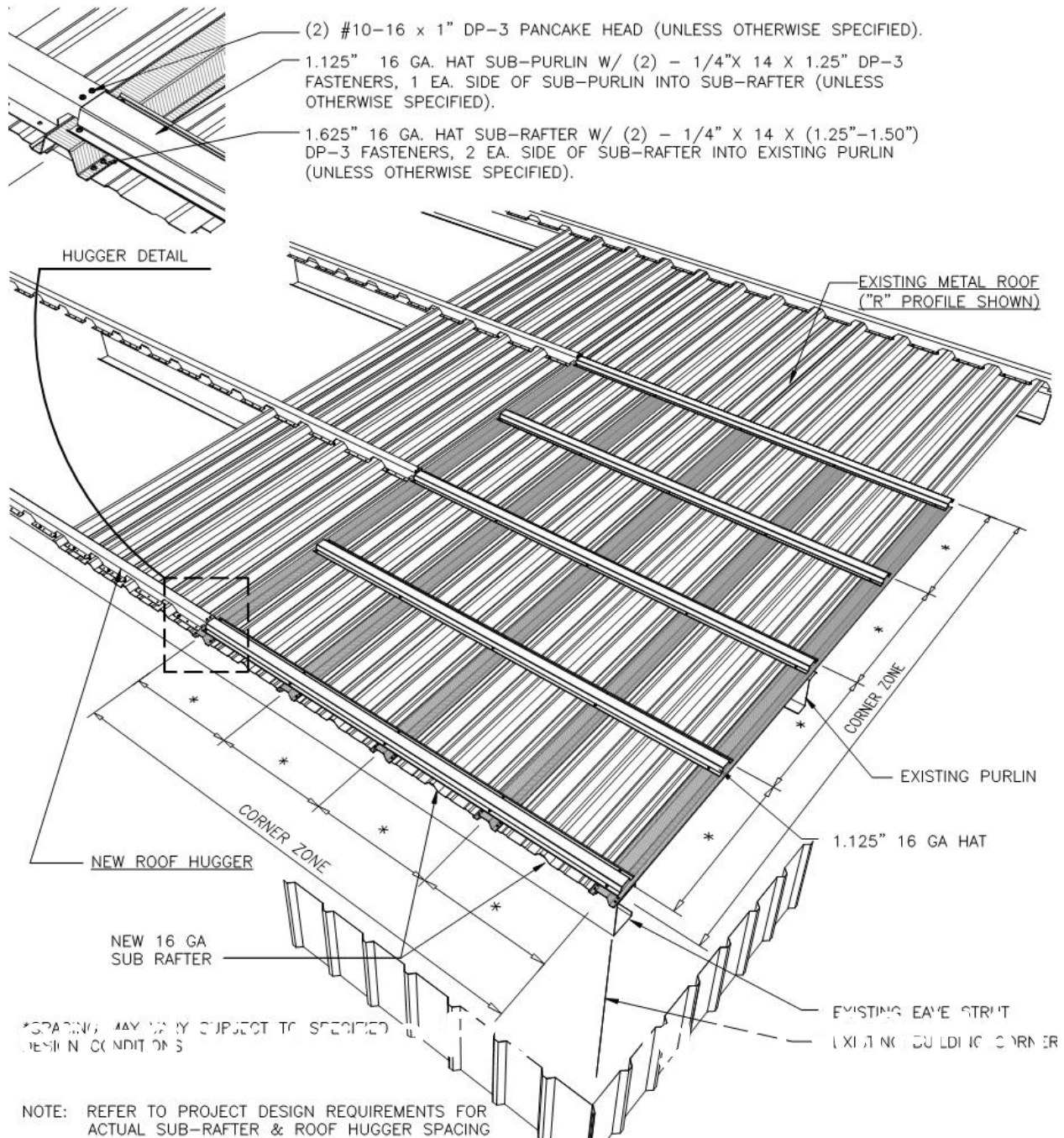

Corner/Edge Zone Framing (ZF-06-HAT-V)

Corner & Edge Zone "Hat Grid" Framing Over Vertical Rib SSR

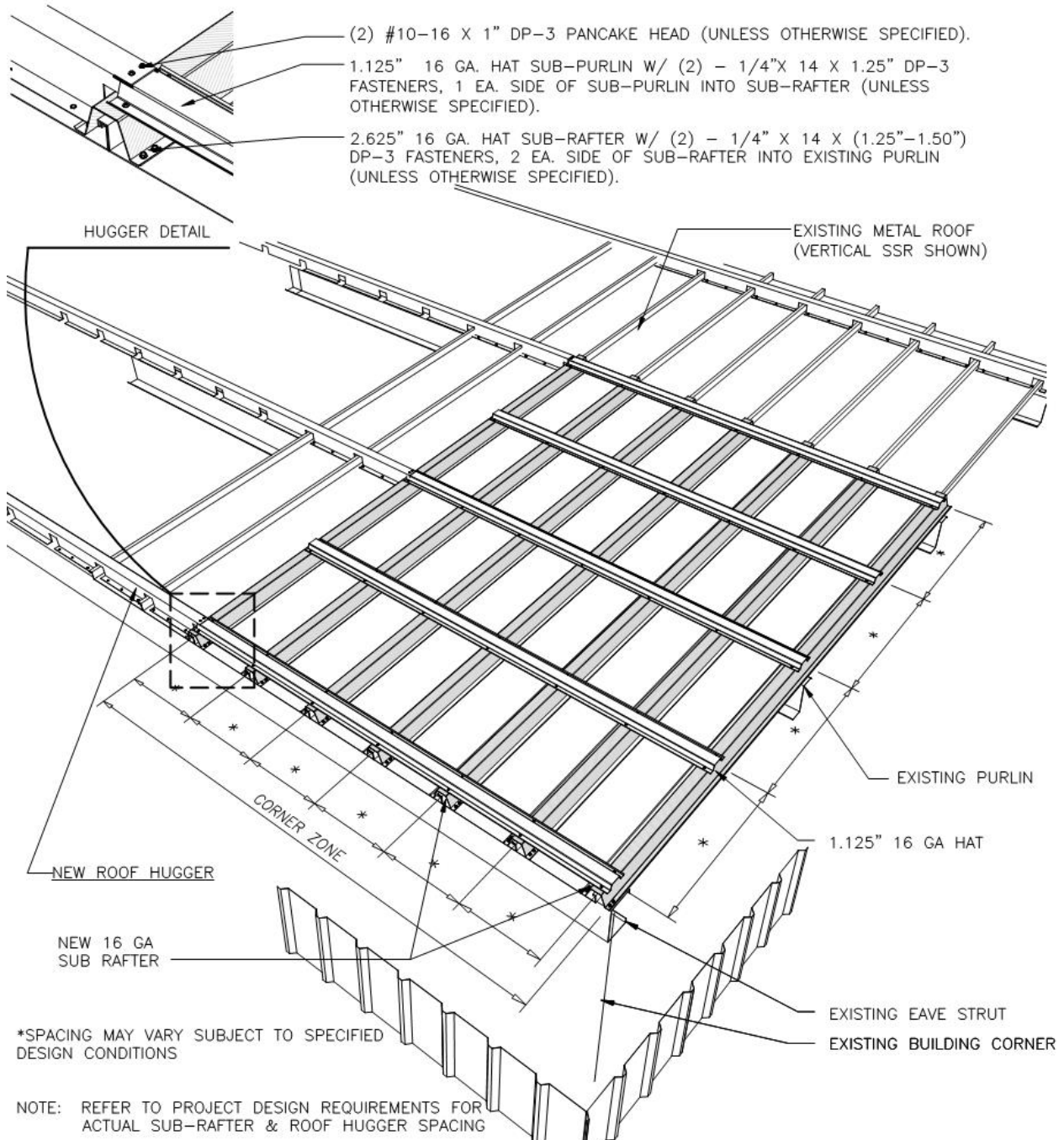

Low Eave (LE-01-G)

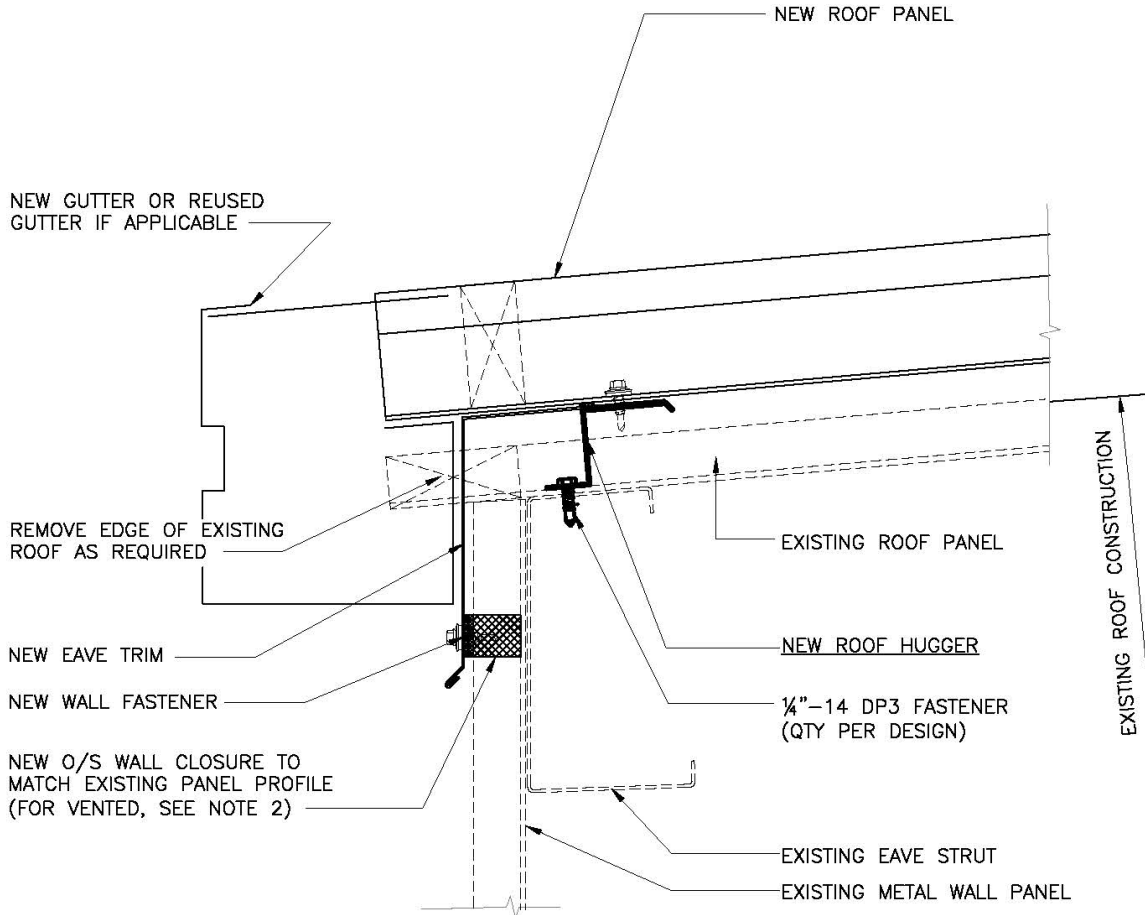

NOTES:

1. ALL FASTENERS NOT BY ROOF HUGGER UNLESS NOTED OTHERWISE
2. FOR VENTED LOW EAVE, USE "LP" VENTED CLOSURE AS MANUFACTURED BY MARCO INDUSTRIES - TULSA, OK OR OTHER AS PREFERRED.
3. ALL NEW ROOF SYSTEMS INCLUDING PANEL, FASTENERS, TRIM AND ACCESSORIES TO BE INSTALLED PER THAT MANUFACTURER'S STANDARDS.

Low Eave (LE-02-R/R)

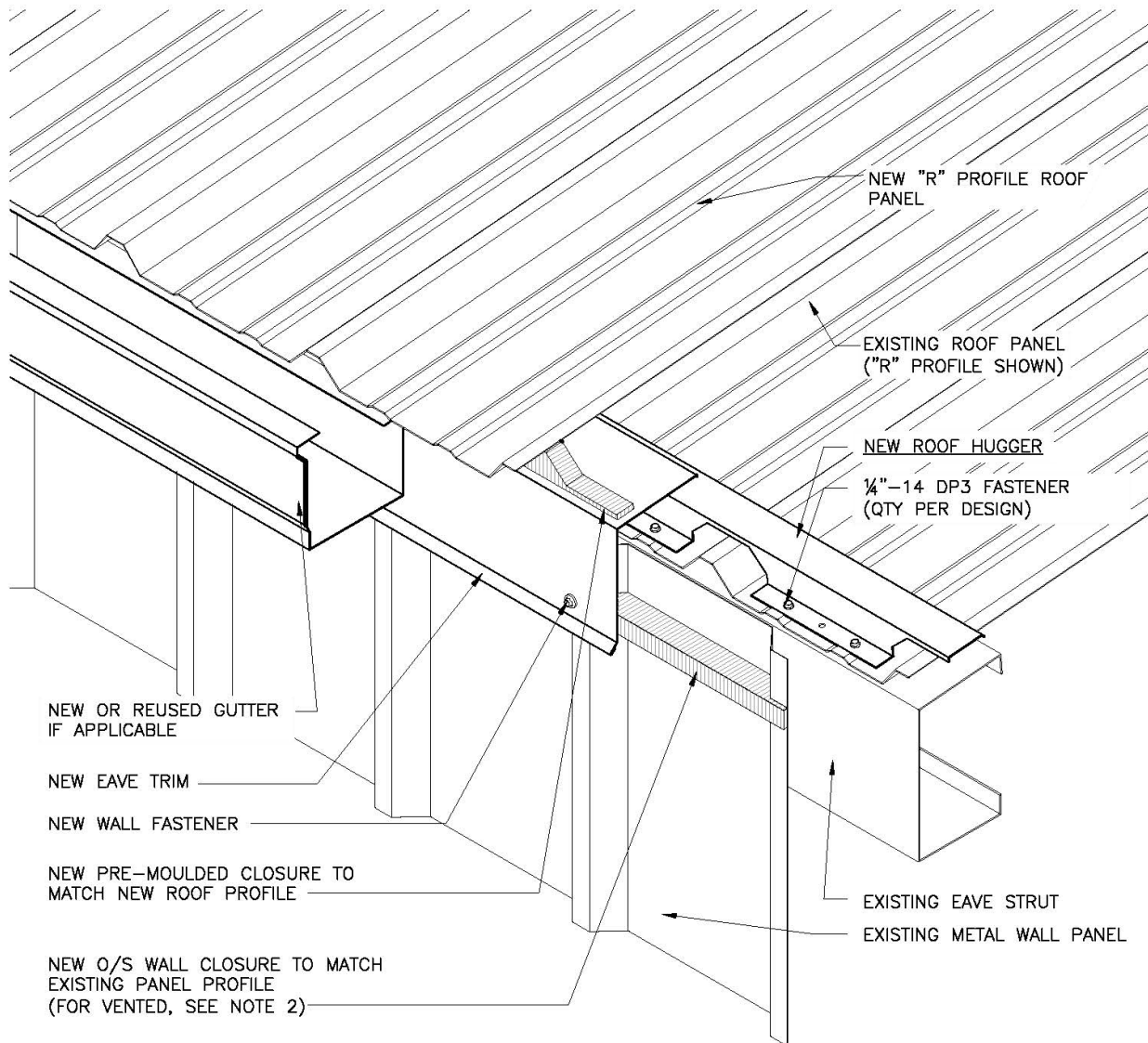

NOTES:

1. ALL FASTENERS NOT BY ROOF HUGGER UNLESS NOTED OTHERWISE
2. FOR VENTED LOW EAVE, USE "LP" VENTED CLOSURE AS MANUFACTURED BY MARCO INDUSTRIES - TULSA, OK OR OTHER AS PREFERRED.
3. ALL NEW ROOF SYSTEMS INCLUDING PANEL, FASTENERS, TRIM AND ACCESSORIES TO BE INSTALLED PER THAT MANUFACTURER'S STANDARDS.

Low Eave (LE-02-T/R)

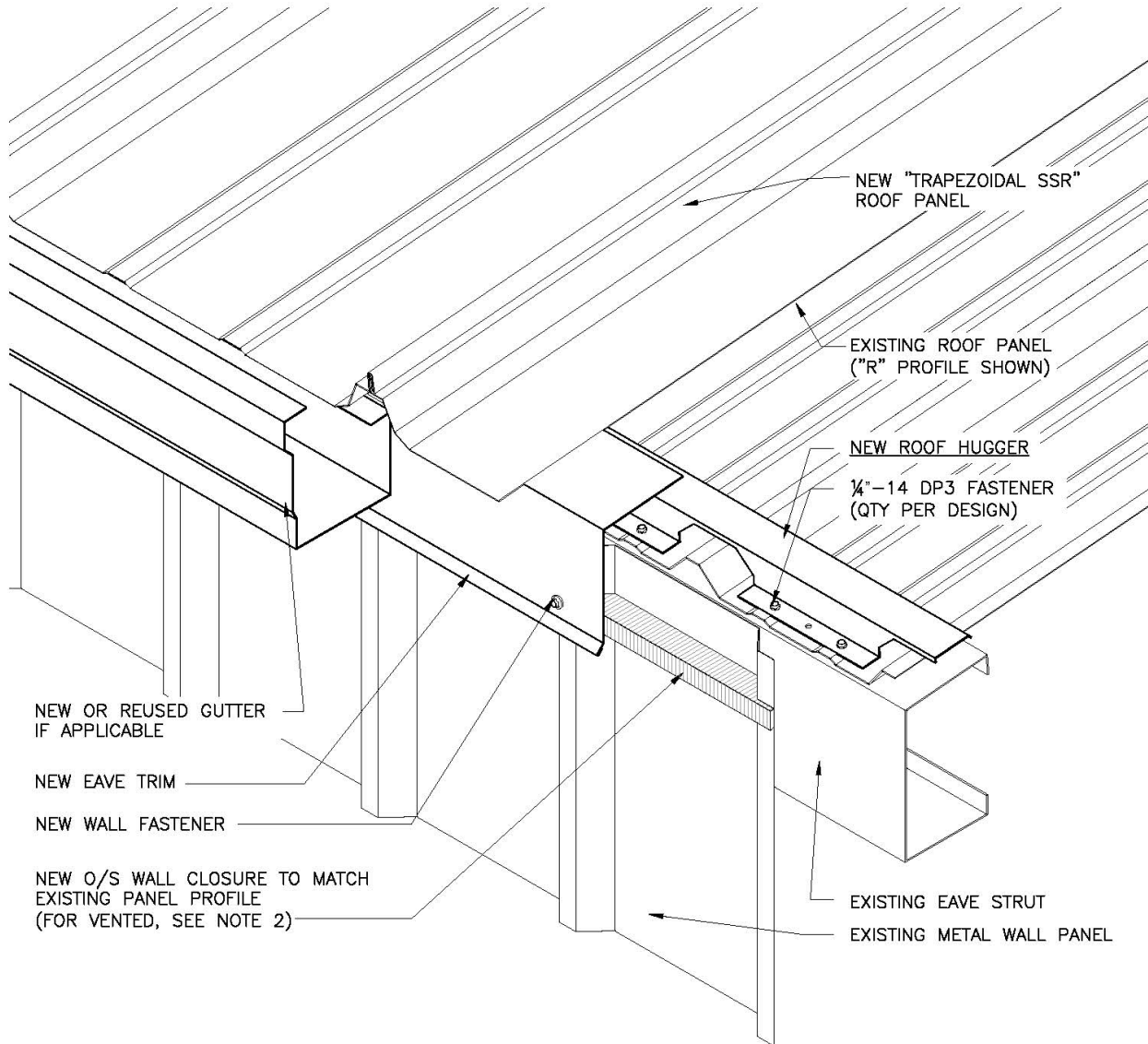

NOTES:

1. ALL FASTENERS NOT BY ROOF HUGGER UNLESS NOTED OTHERWISE
2. FOR VENTED LOW EAVE, USE "LP" VENTED CLOSURE AS MANUFACTURED BY MARCO INDUSTRIES - TULSA, OK OR OTHER AS PREFERRED.
3. ALL NEW ROOF SYSTEMS INCLUDING PANEL, FASTENERS, TRIM AND ACCESSORIES TO BE INSTALLED PER THAT MANUFACTURER'S STANDARDS.

Low Eave (LE-03-T/T)

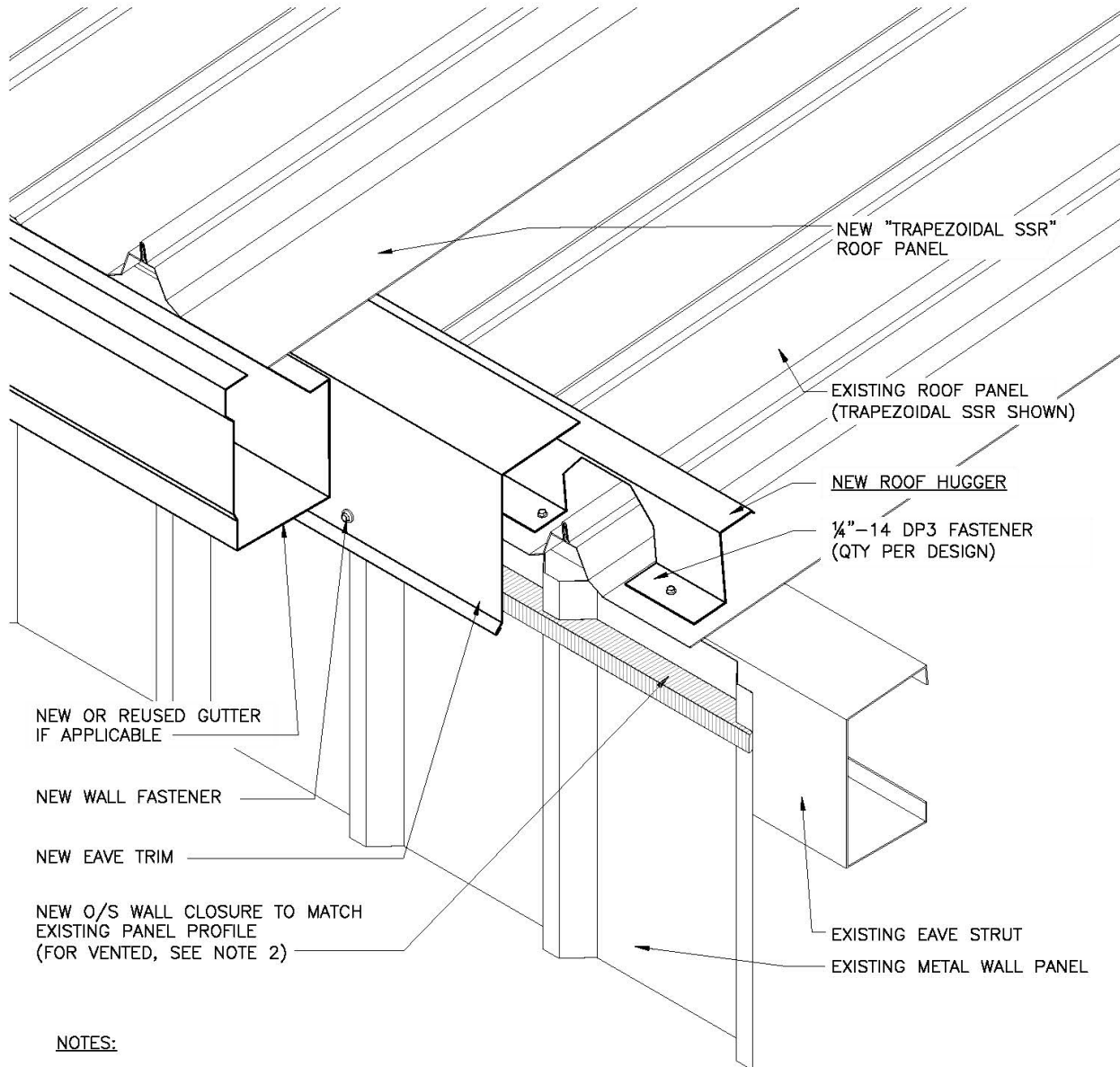

NOTES:

1. ALL FASTENERS NOT BY ROOF HUGGER UNLESS NOTED OTHERWISE
2. FOR VENTED LOW EAVE, USE "LP" VENTED CLOSURE AS MANUFACTURED BY MARCO INDUSTRIES - TULSA, OK OR OTHER AS PREFERRED.
3. ALL NEW ROOF SYSTEMS INCLUDING PANEL, FASTENERS, TRIM AND ACCESSORIES TO BE INSTALLED PER THAT MANUFACTURER'S STANDARDS.

Low Eave (LE-04-T/V)

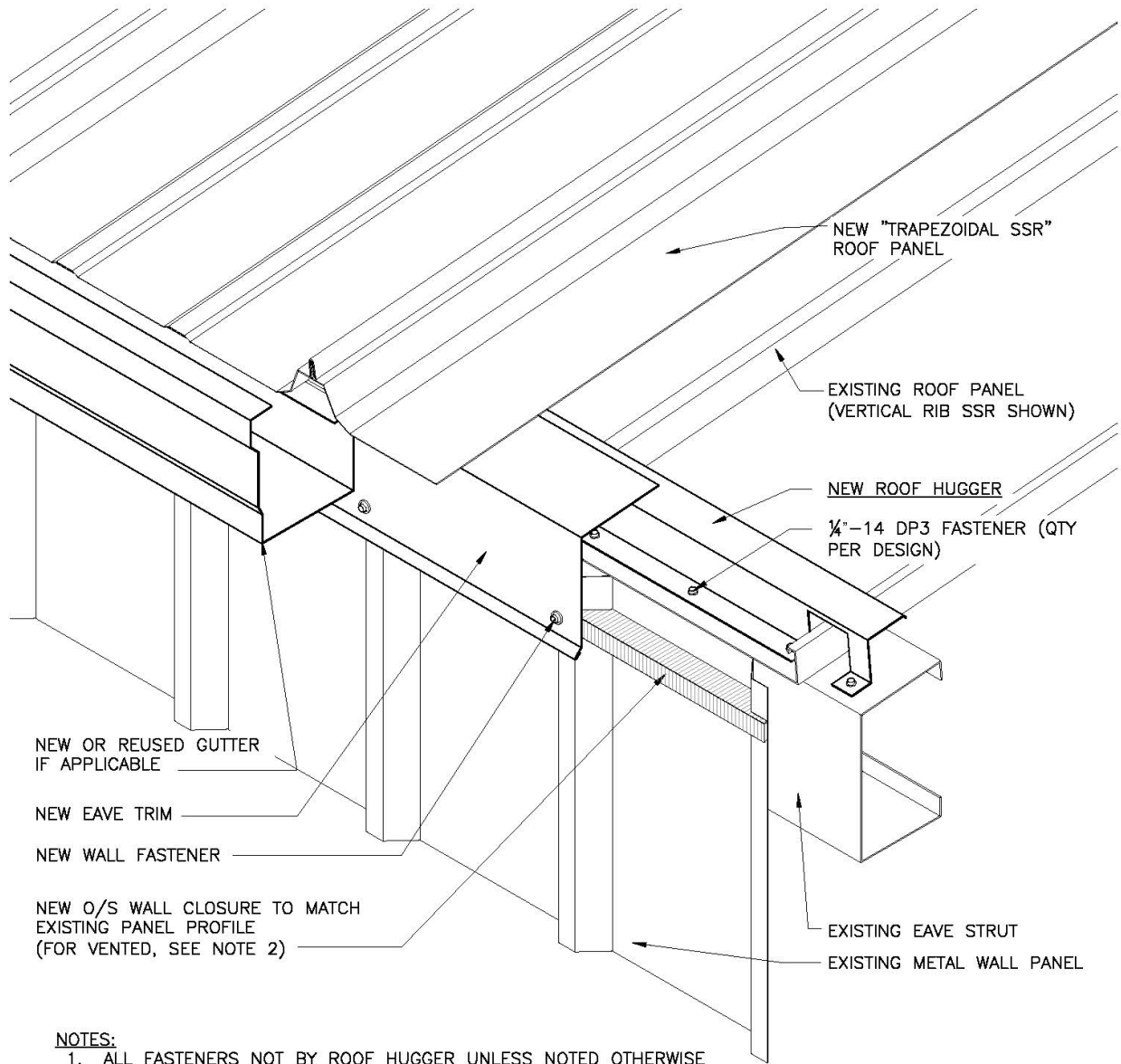

- NOTES:**
1. ALL FASTENERS NOT BY ROOF HUGGER UNLESS NOTED OTHERWISE
 2. FOR VENTED LOW EAVE, USE "LP" VENTED CLOSURE AS MANUFACTURED BY MARCO INDUSTRIES – TULSA, OK OR OTHER AS PREFERRED.
 3. ALL NEW ROOF SYSTEMS INCLUDING PANEL, FASTENERS, TRIM AND ACCESSORIES TO BE INSTALLED PER THAT MANUFACTURER'S STANDARDS.

Low Eave (LE-05-V/V)

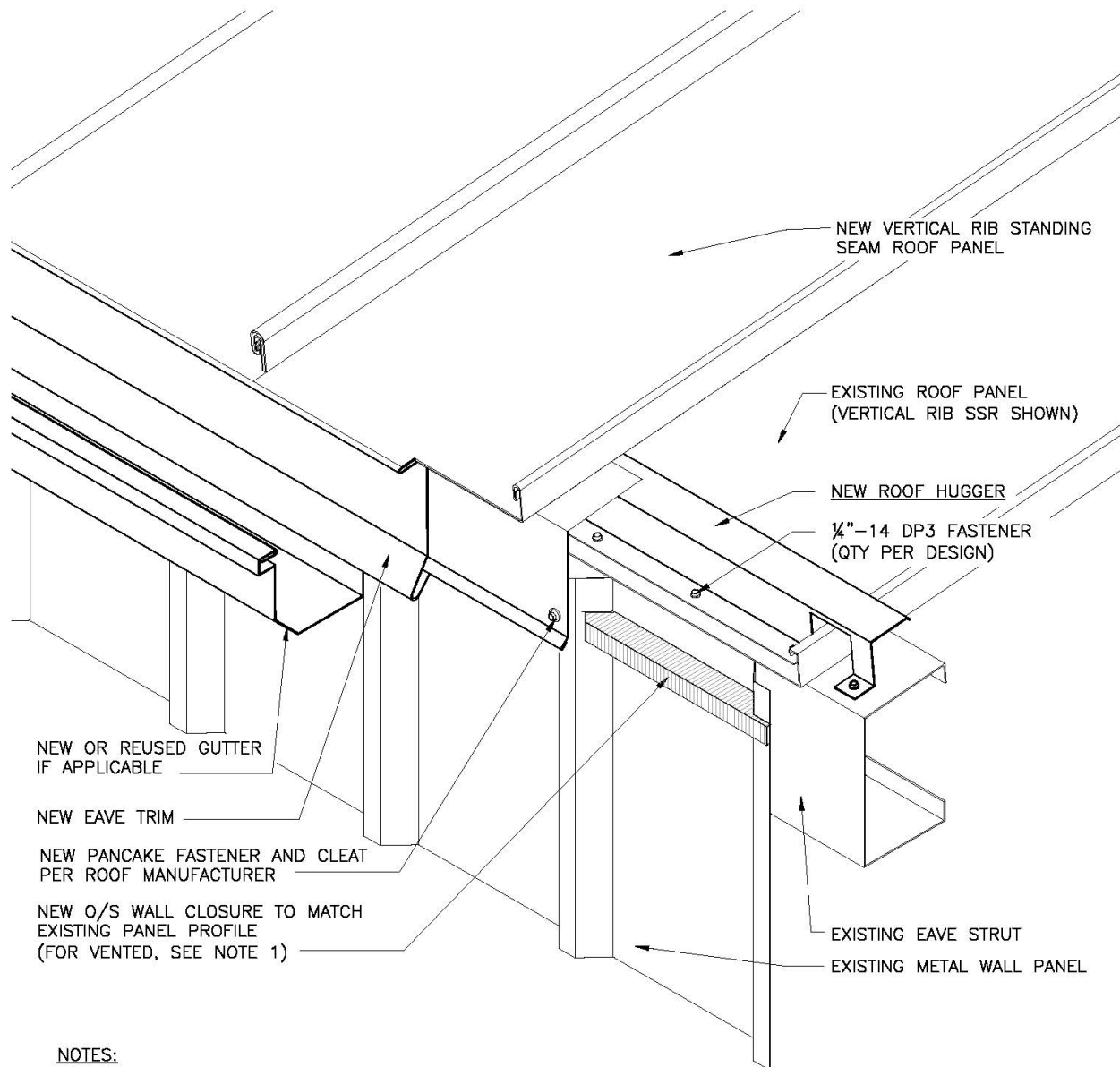

NOTES:

1. FOR VENTED LOW EAVE, USE "LP" VENTED CLOSURE AS MANUFACTURED BY MARCO INDUSTRIES - TULSA, OK OR OTHER AS PREFERRED.
2. ALL FASTENERS NOT BY ROOF HUGGER UNLESS NOTED OTHERWISE.
3. ALL NEW ROOF SYSTEMS INCLUDING PANEL, FASTENERS, TRIM AND ACCESSORIES TO BE INSTALLED PER THAT MANUFACTURER'S STANDARDS.

Low Eave (LE-06-V/R)

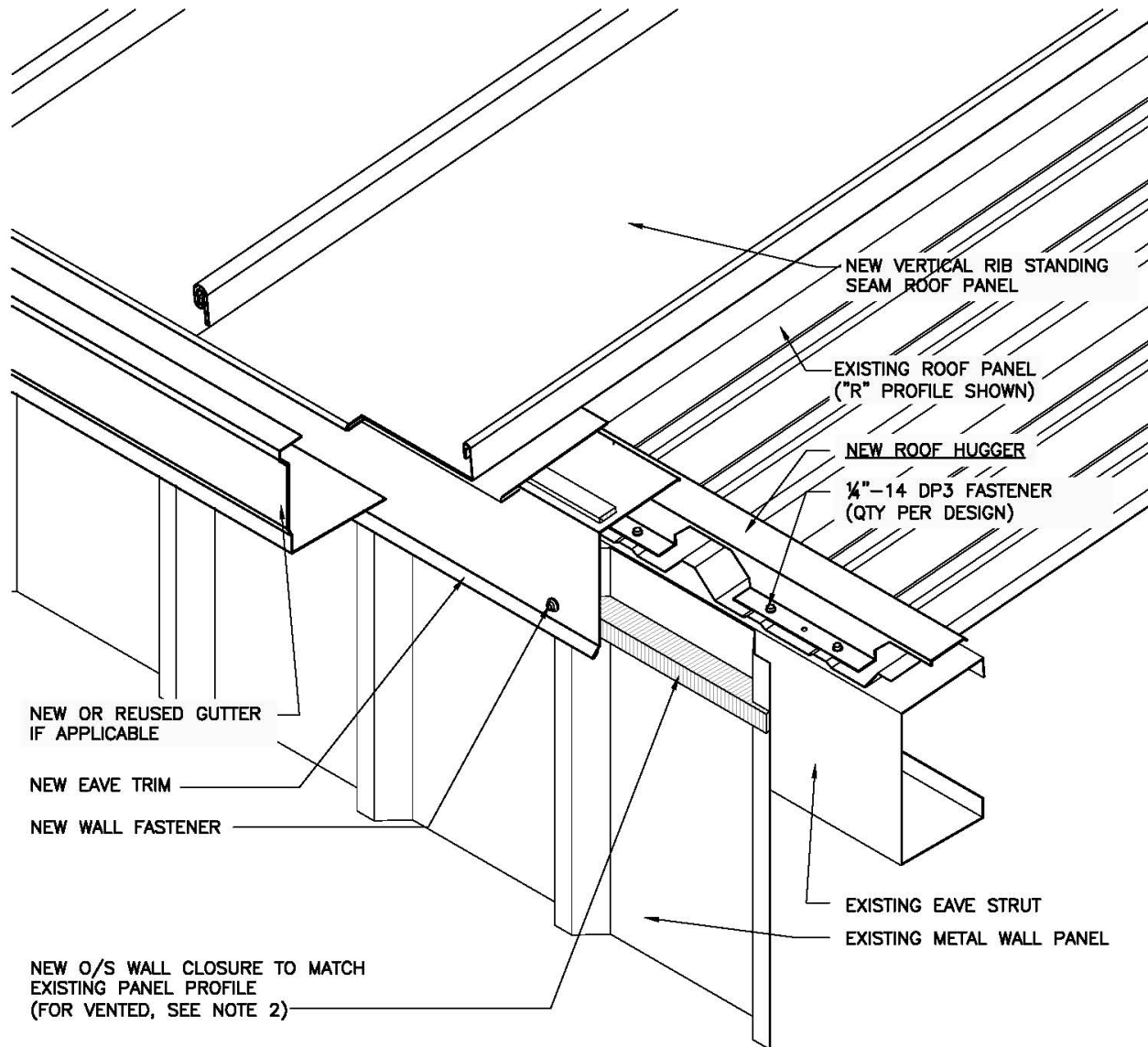

NOTES:

1. ALL FASTENERS NOT BY ROOF HUGGER UNLESS NOTED OTHERWISE
2. FOR VENTED LOW EAVE, USE "LP" VENTED CLOSURE AS MANUFACTURED BY MARCO INDUSTRIES - TULSA, OK OR OTHER AS PREFERRED.
3. ALL NEW ROOF SYSTEMS INCLUDING PANEL, FASTENERS, TRIM AND ACCESSORIES TO BE INSTALLED PER THAT MANUFACTURER'S STANDARDS.

Low Eave (LE-07-T/T)

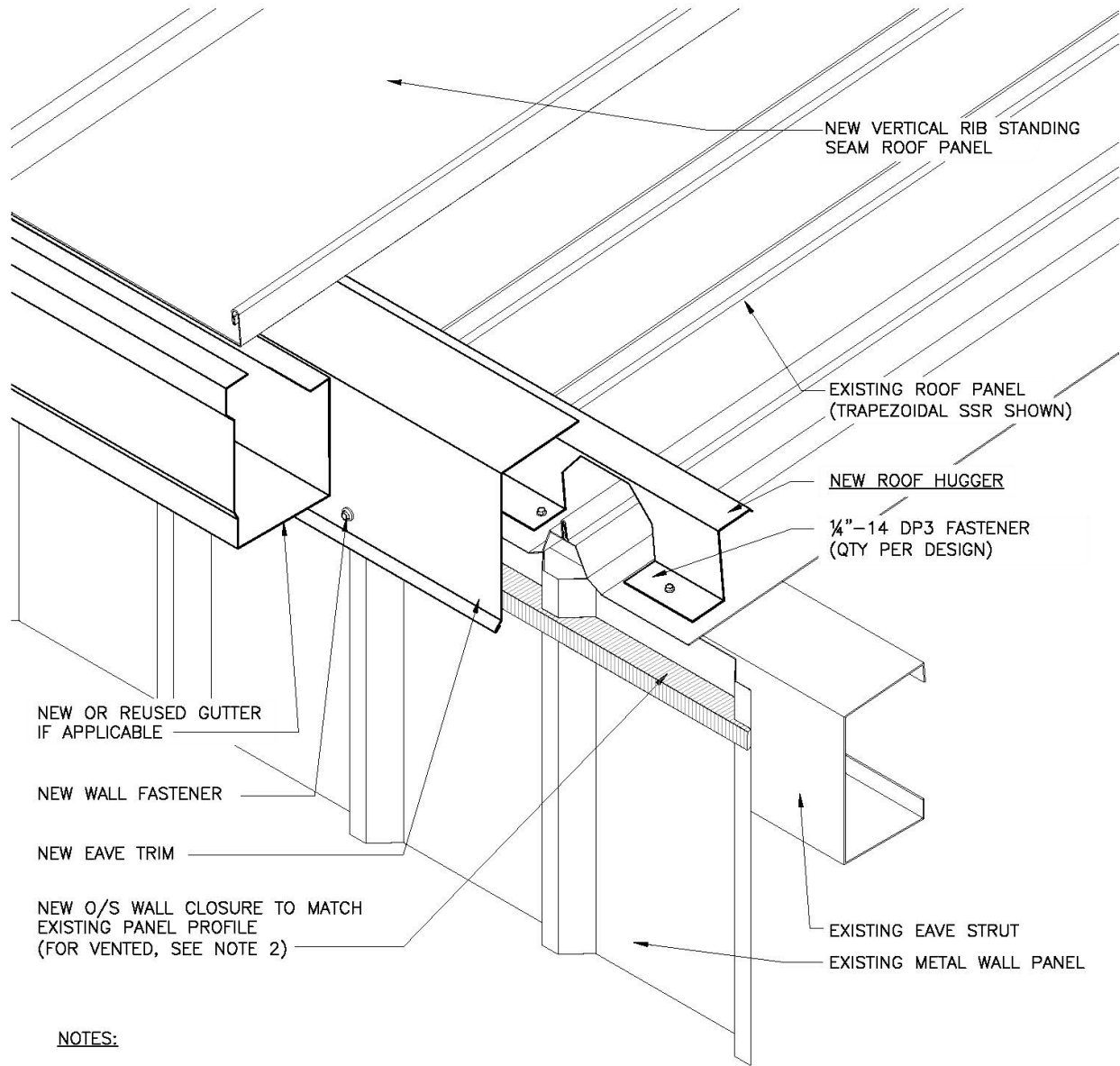

NEW OR REUSED GUTTER
IF APPLICABLE

NEW WALL FASTENER

NEW EAVE TRIM

NEW O/S WALL CLOSURE TO MATCH
EXISTING PANEL PROFILE
(FOR VENTED, SEE NOTE 2)

NEW VERTICAL RIB STANDING
SEAM ROOF PANEL

EXISTING ROOF PANEL
(TRAPEZOIDAL SSR SHOWN)

NEW ROOF HUGGER

1/4\"-14 DP3 FASTENER
(QTY PER DESIGN)

EXISTING EAVE STRUT

EXISTING METAL WALL PANEL

NOTES:

1. ALL FASTENERS NOT BY ROOF HUGGER UNLESS NOTED OTHERWISE
2. FOR VENTED LOW EAVE, USE "LP" VENTED CLOSURE AS MANUFACTURED BY MARCO INDUSTRIES - TULSA, OK OR OTHER AS PREFERRED.
3. ALL NEW ROOF SYSTEMS INCLUDING PANEL, FASTENERS, TRIM AND ACCESSORIES TO BE INSTALLED PER THAT MANUFACTURER'S STANDARDS.

High Eave Non-Vented (HE-01-G)

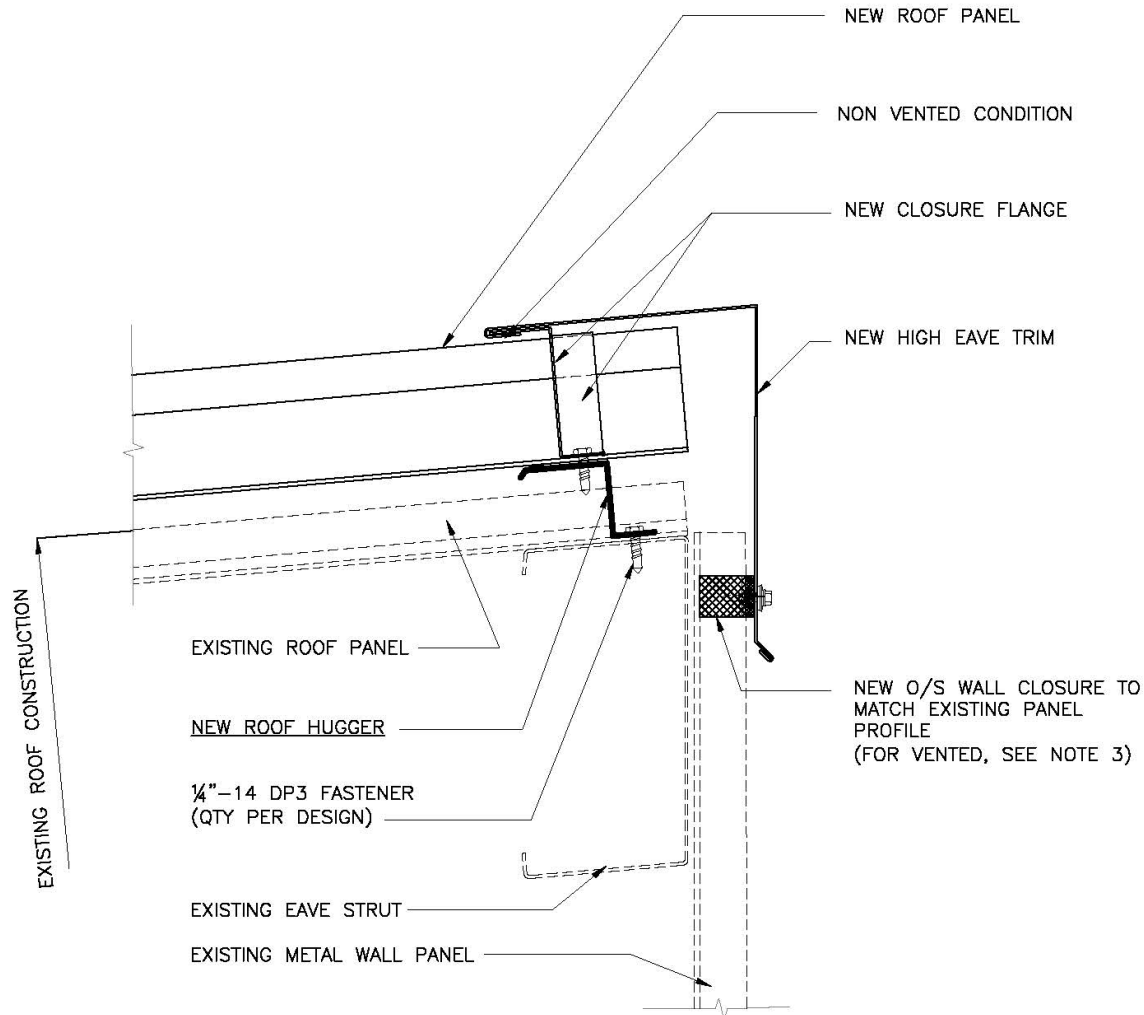

NOTES:

1. ALL FASTENERS NOT BY ROOF HUGGER UNLESS NOTED OTHERWISE.
2. ALL NEW ROOF SYSTEMS INCLUDING PANEL, FASTENERS, TRIM AND ACCESSORIES TO BE INSTALLED PER THAT MANUFACTURER'S STANDARDS.
3. FOR VENTED HIGH EAVE, USE "LP" VENTED CLOSURE AS MANUFACTURED BY MARCO INDUSTRIES - TULSA, OK OR OTHER AS PREFERRED.

High Eave (HE-02-R/R)

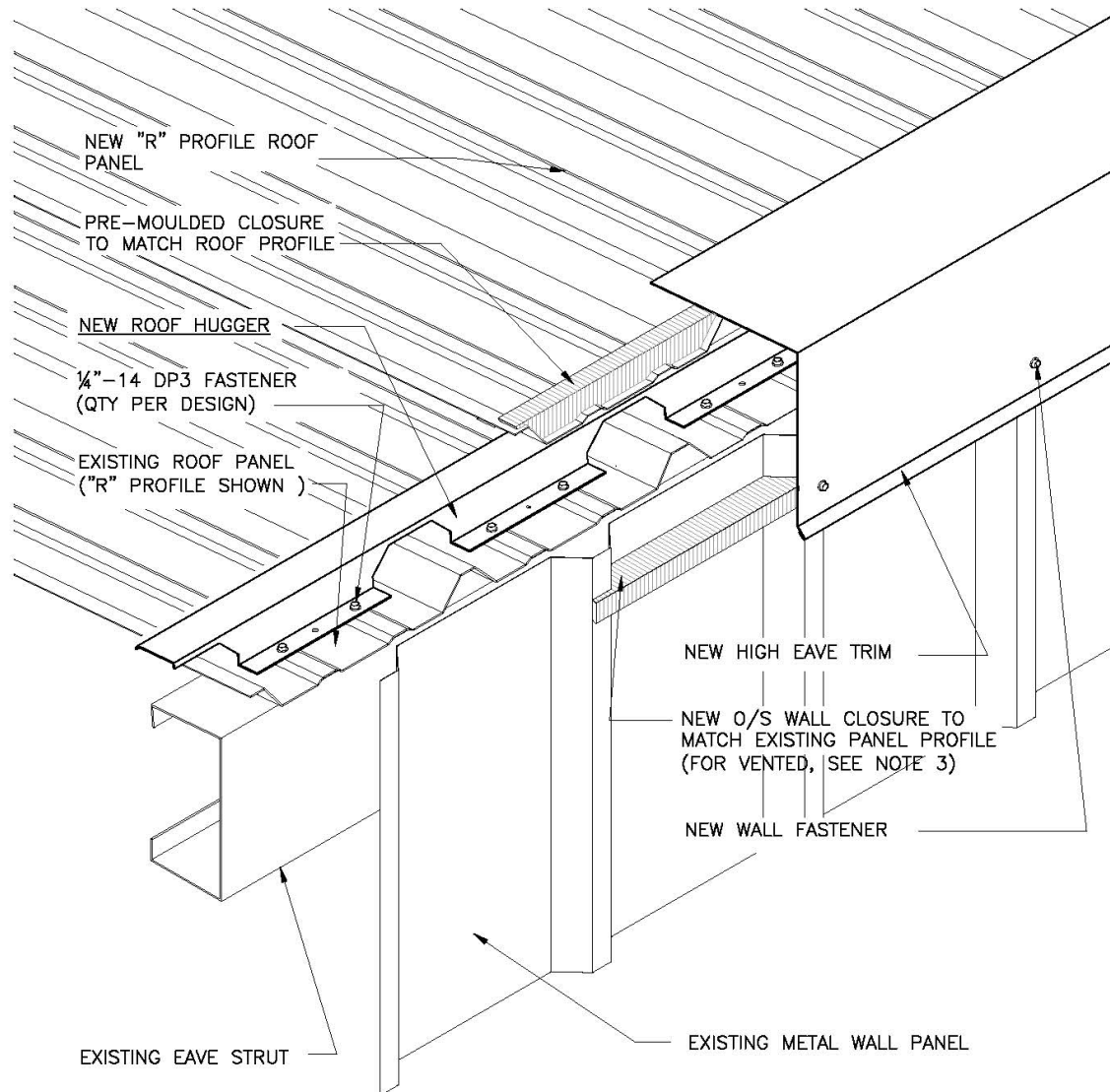

NOTES:

1. ALL FASTENERS NOT BY ROOF HUGGER UNLESS NOTED OTHERWISE.
2. ALL NEW ROOF SYSTEMS INCLUDING PANEL, FASTENERS, TRIM AND ACCESSORIES TO BE INSTALLED PER THAT MANUFACTURER'S STANDARDS.
3. FOR VENTED HIGH EAVE, USE "LP" VENTED CLOSURE AS MANUFACTURED BY MARCO INDUSTRIES - TULSA, OK OR OTHER AS PREFERRED.

High Eave (HE-02-T/R)

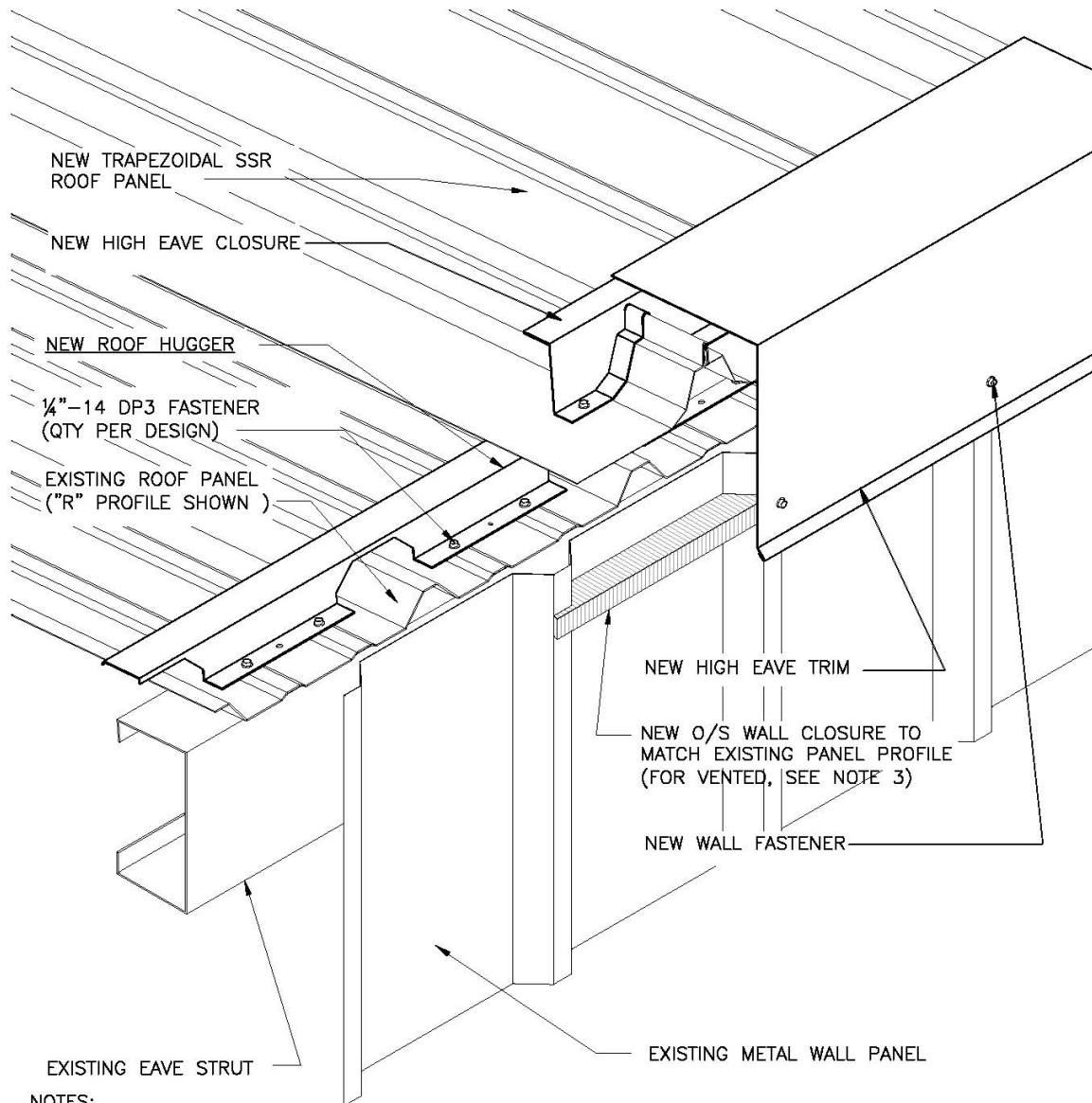

NOTES:

1. ALL FASTENERS NOT BY ROOF HUGGER UNLESS NOTED OTHERWISE.
2. ALL NEW ROOF SYSTEMS INCLUDING PANEL, FASTENERS, TRIM AND ACCESSORIES TO BE INSTALLED PER THAT MANUFACTURER'S STANDARDS.
3. FOR VENTED HIGH EAVE, USE "LP" VENTED CLOSURE AS MANUFACTURED BY MARCO INDUSTRIES - TULSA, OK OR OTHER AS PREFERRED.

High Eave (HE-03-T/T)

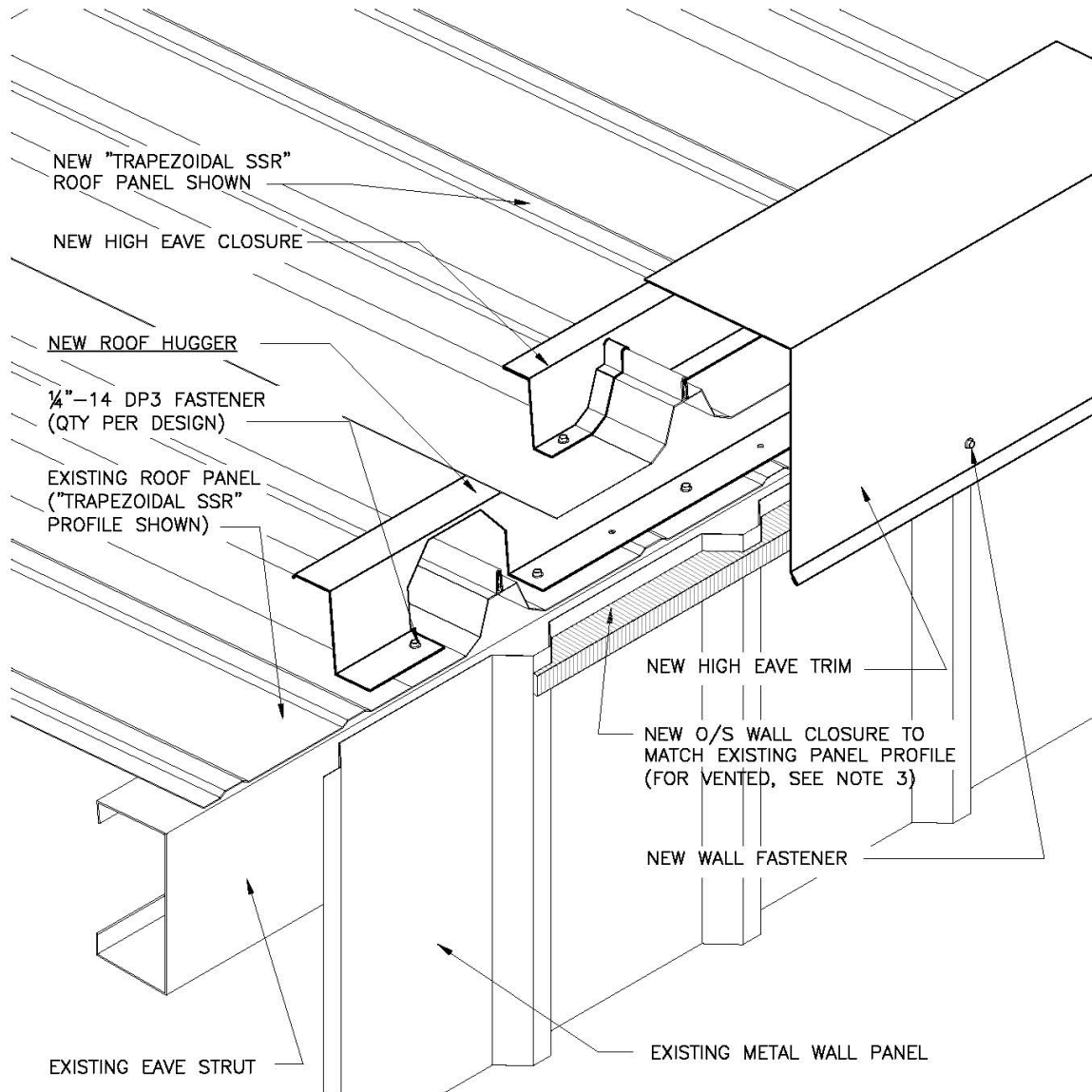

NOTES:

1. ALL FASTENERS NOT BY ROOF HUGGER UNLESS NOTED OTHERWISE.
2. ALL NEW ROOF SYSTEMS INCLUDING PANEL, FASTENERS, TRIM AND ACCESSORIES TO BE INSTALLED PER THAT MANUFACTURER'S STANDARDS.
3. FOR VENTED HIGH EAVE, USE "LP" VENTED CLOSURE AS MANUFACTURED BY MARCO INDUSTRIES - TULSA, OK OR OTHER AS PREFERRED.

High Eave (HE-04-T/V)

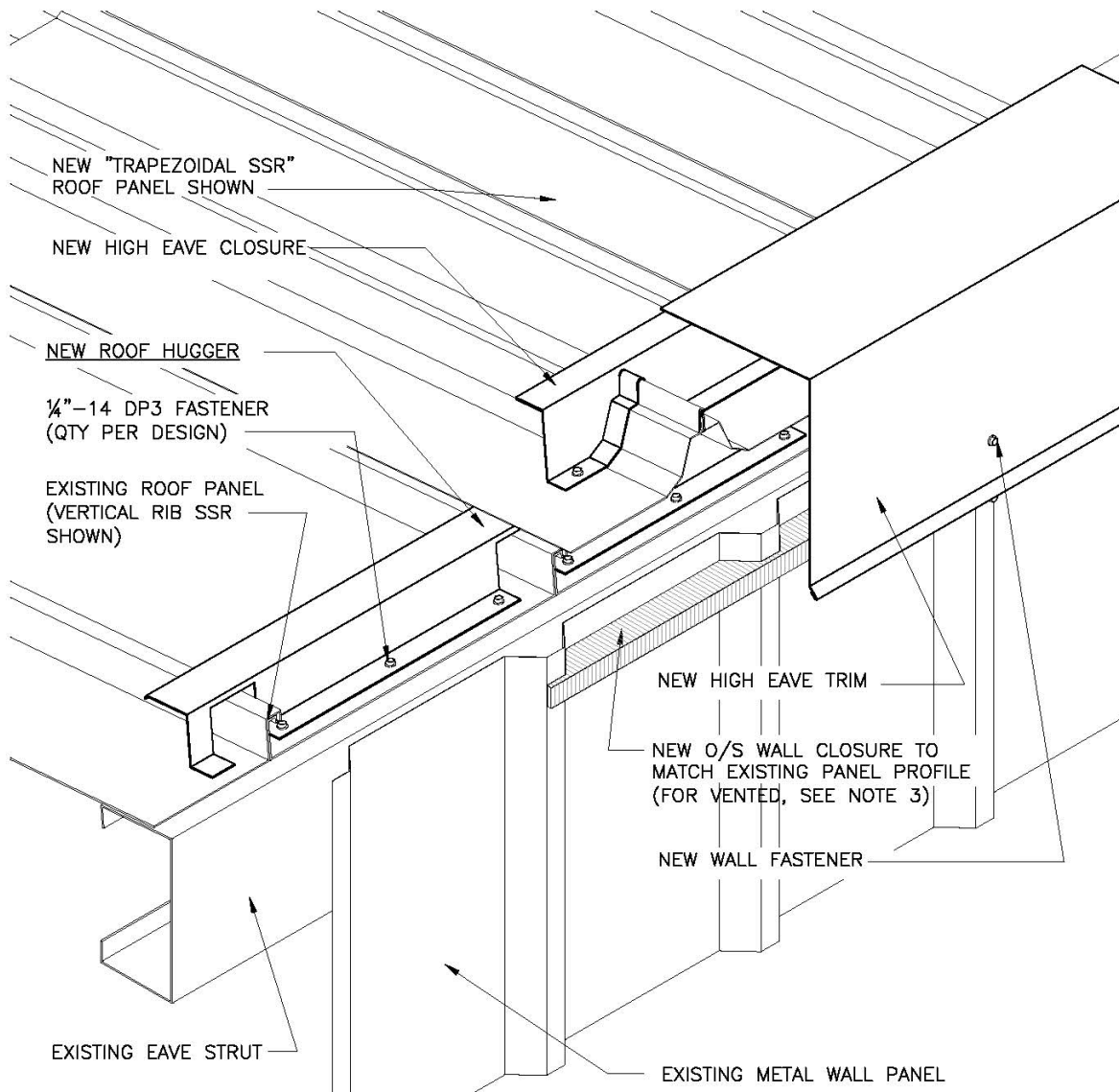

NOTES:

1. ALL FASTENERS NOT BY ROOF HUGGER UNLESS NOTED OTHERWISE.
2. ALL NEW ROOF SYSTEMS INCLUDING PANEL, FASTENERS, TRIM AND ACCESSORIES TO BE INSTALLED PER THAT MANUFACTURER'S STANDARDS.
3. FOR VENTED HIGH EAVE, USE "LP" VENTED CLOSURE AS MANUFACTURED BY MARCO INDUSTRIES - TULSA, OK OR OTHER AS PREFERRED.

High Eave (HE-05-V/V)

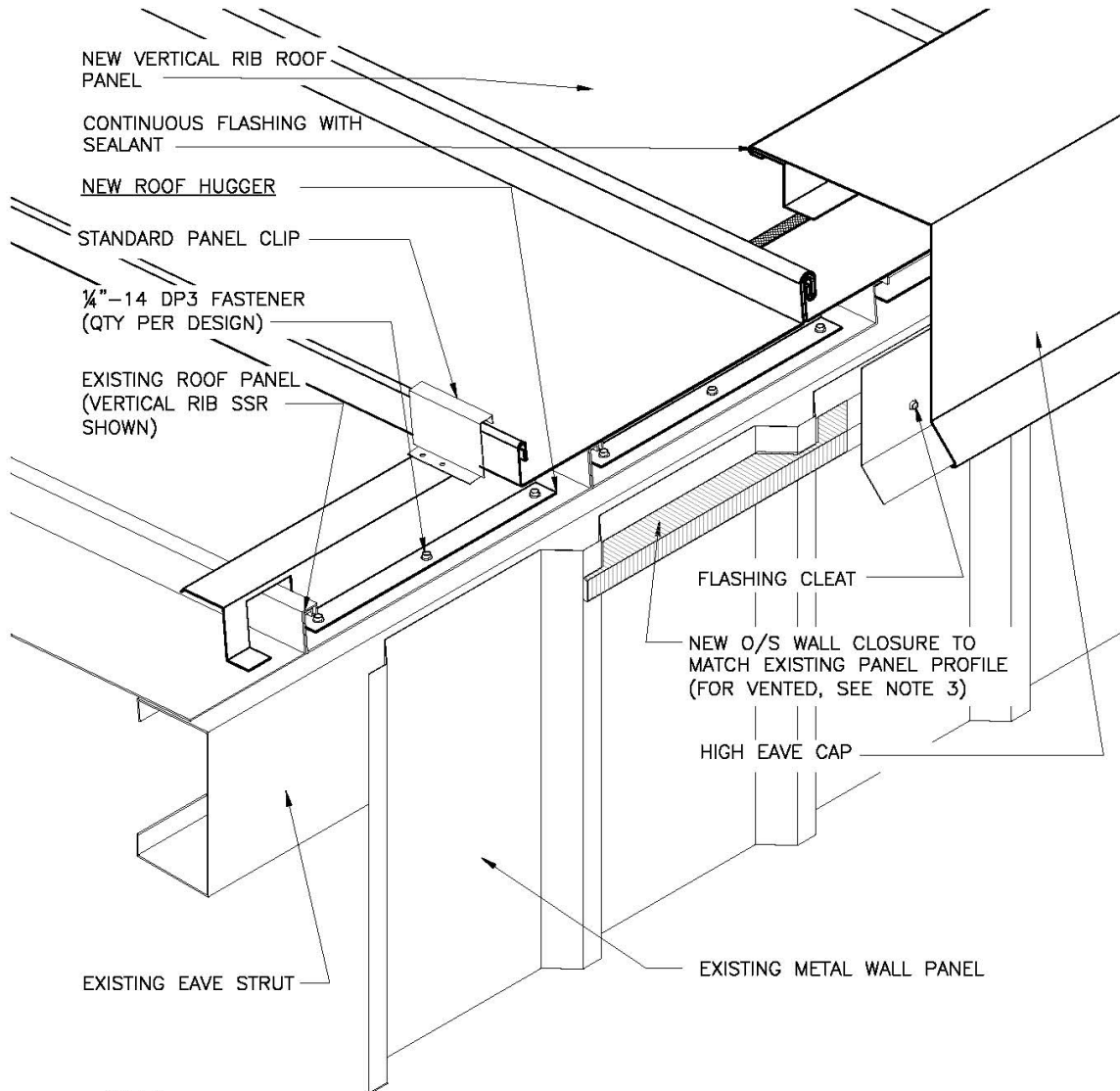

NOTES:

1. ALL FASTENERS NOT BY ROOF HUGGER UNLESS NOTED OTHERWISE.
2. ALL NEW ROOF SYSTEMS INCLUDING PANEL, FASTENERS, TRIM AND ACCESSORIES TO BE INSTALLED PER THAT MANUFACTURER'S STANDARDS.
3. FOR VENTED HIGH EAVE, USE "LP" VENTED CLOSURE AS MANUFACTURED BY MARCO INDUSTRIES - TULSA, OK OR OTHER AS PREFERRED.

High Eave Vented (HE-06-V/T)

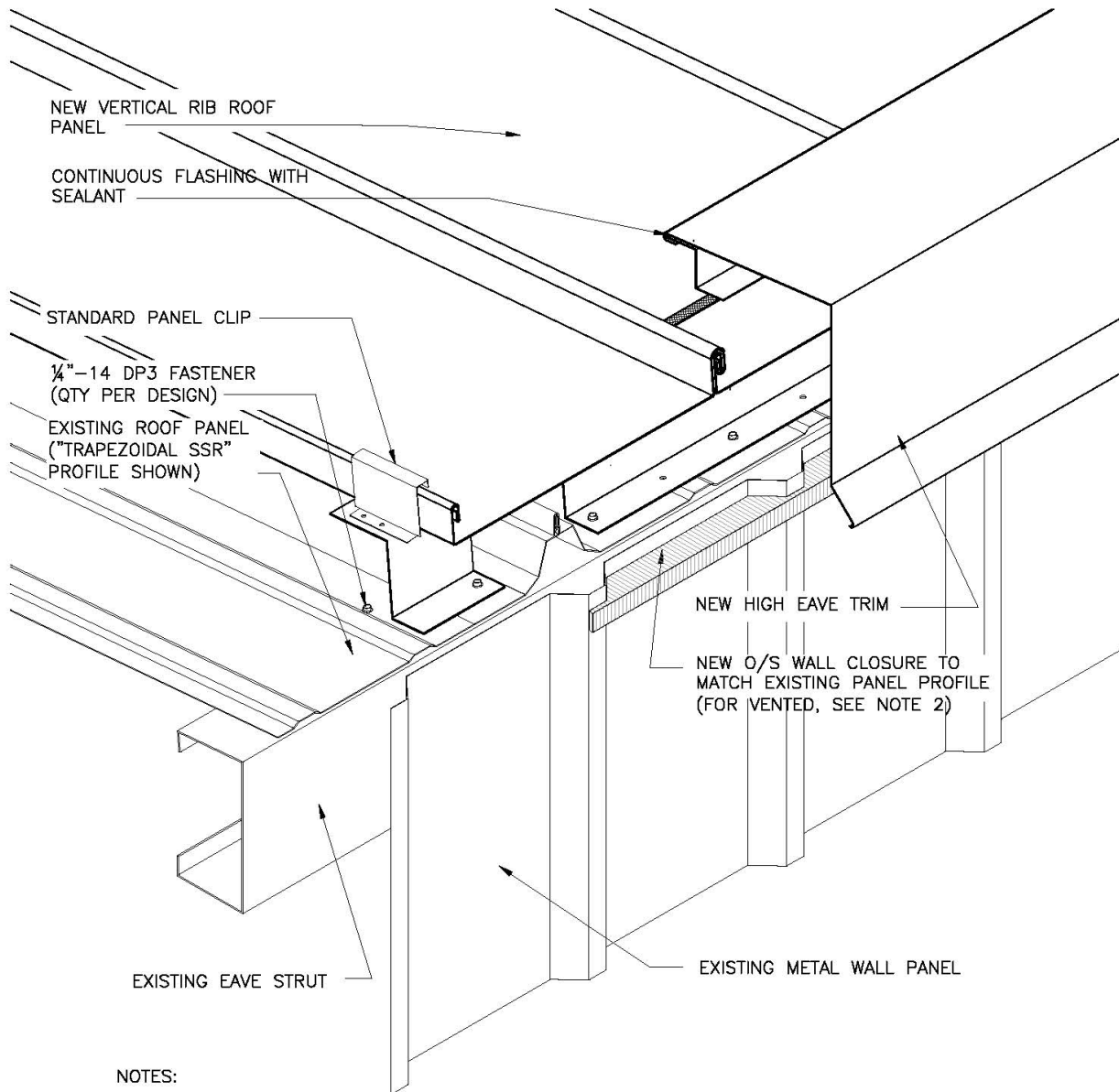

NOTES:

1. ALL FASTENERS NOT BY ROOF HUGGER UNLESS NOTED OTHERWISE.
2. ALL NEW ROOF SYSTEMS INCLUDING PANEL, FASTENERS, TRIM AND ACCESSORIES TO BE INSTALLED PER THAT MANUFACTURER'S STANDARDS.
3. ALL NEW ROOF SYSTEMS INCLUDING PANEL, FASTENERS, TRIM AND ACCESSORIES TO BE INSTALLED PER THAT MANUFACTURER'S STANDARDS.

High Eave Vented (HE-07-V/R)

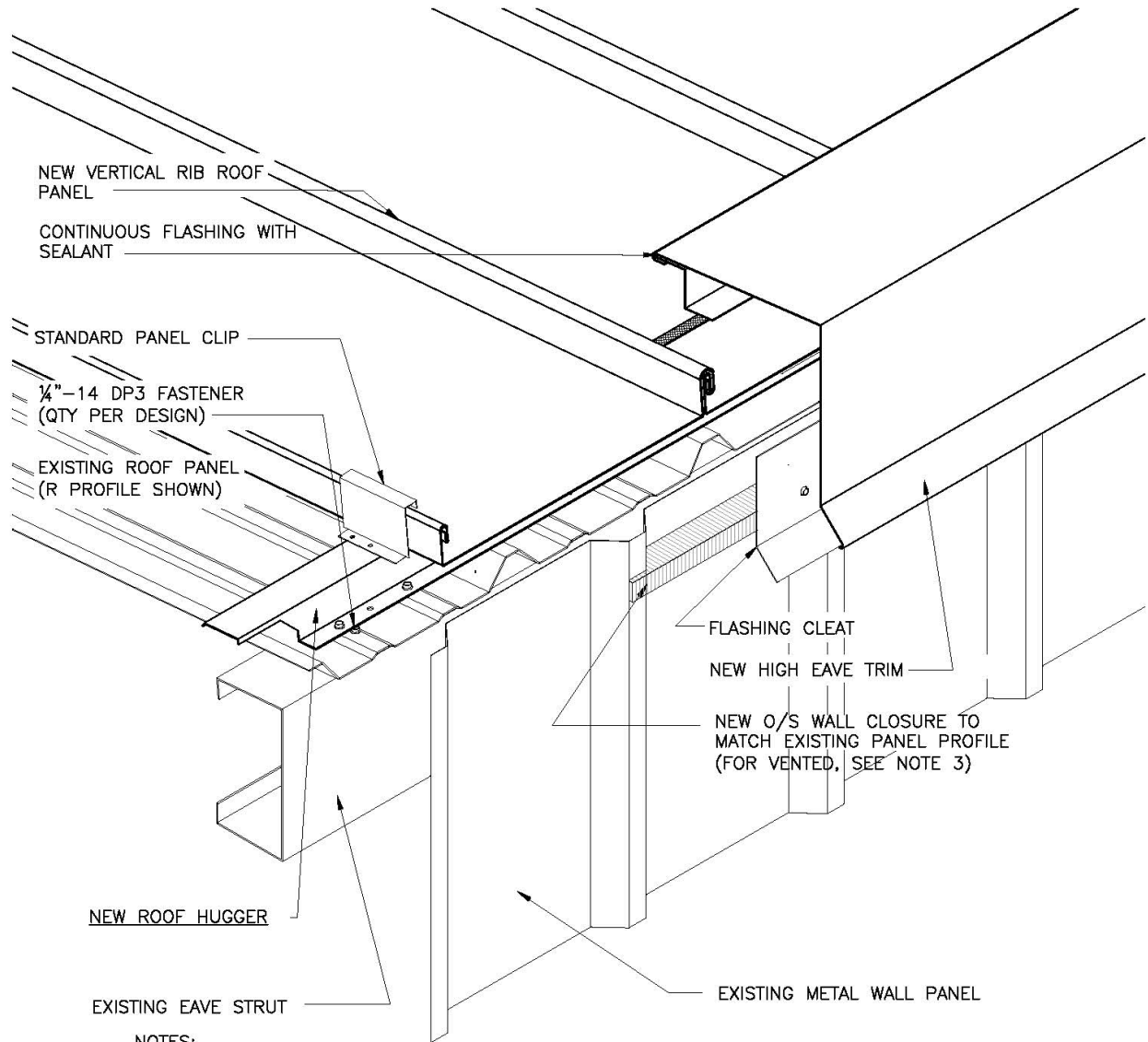

NOTES:

1. ALL FASTENERS NOT BY ROOF HUGGER UNLESS NOTED OTHERWISE.
2. ALL NEW ROOF SYSTEMS INCLUDING PANEL, FASTENERS, TRIM AND ACCESSORIES TO BE INSTALLED PER THAT MANUFACTURER'S STANDARDS.
3. FOR VENTED HIGH EAVE, USE "LP" VENTED CLOSURE AS MANUFACTURED BY MARCO INDUSTRIES - TULSA, OK OR OTHER AS PREFERRED.

Rake/Endwall (RE-01-R/R)

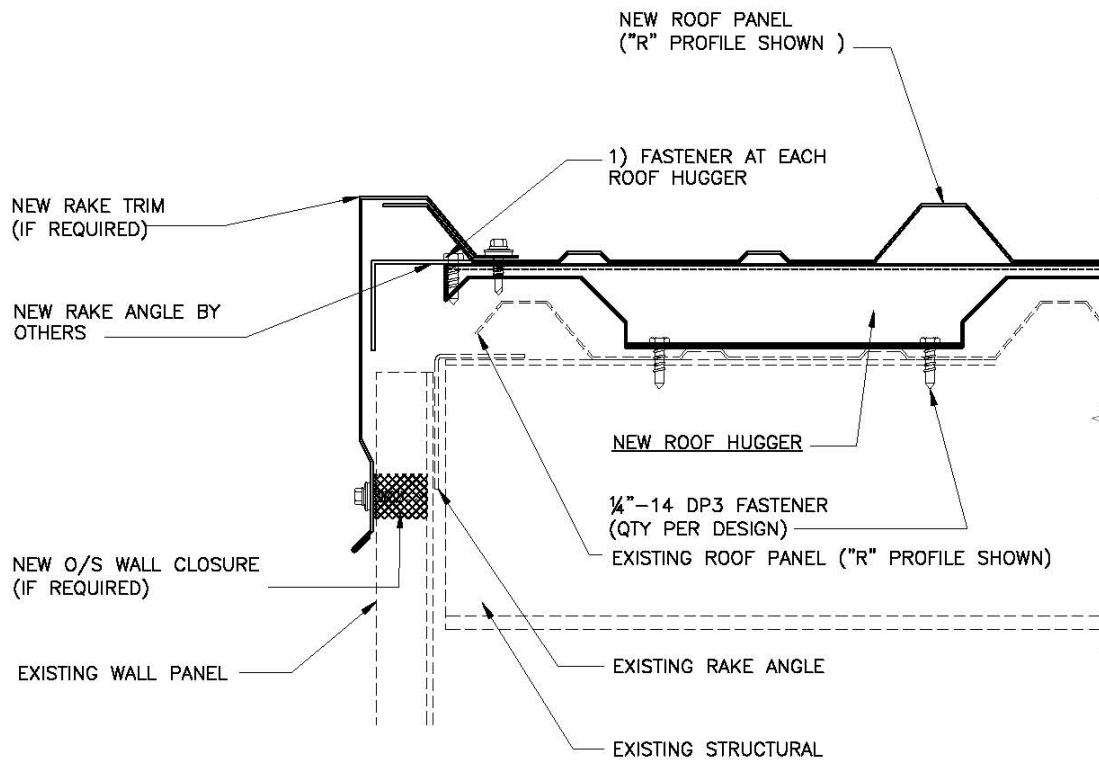

NOTES:

1. ALL FASTENERS NOT BY ROOF HUGGER UNLESS NOTED OTHERWISE.
2. ALL NEW ROOF SYSTEMS INCLUDING PANEL, FASTENERS, TRIM AND ACCESSORIES TO BE INSTALLED PER THAT MANUFACTURER'S STANDARDS.
3. IF OLD RAKE TRIM IS REMOVED, NEW RAKE TRIM MAY NEED TO EXTEND TO OLD TRIM LINE DUE TO WALL PANEL COLOR FADE.

Rake/Endwall (RE-02-T/R)

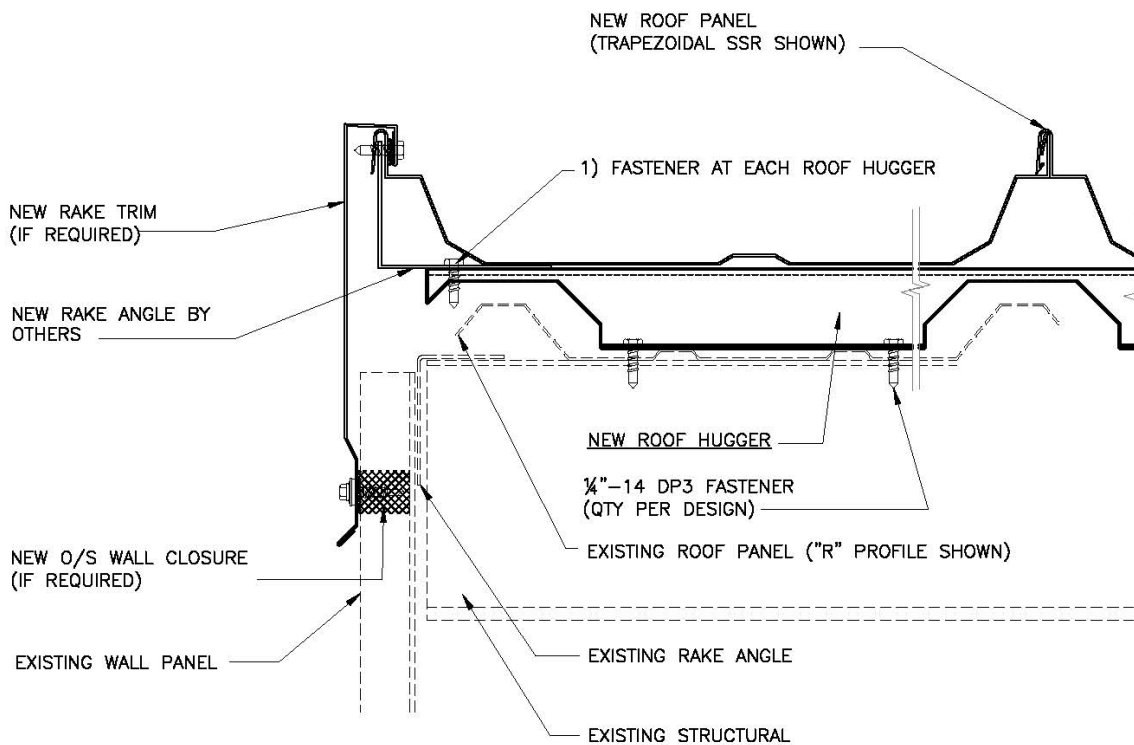

NOTES:

1. ALL FASTENERS NOT BY ROOF HUGGER UNLESS NOTED OTHERWISE.
2. ALL NEW ROOF SYSTEMS INCLUDING PANEL, FASTENERS, TRIM AND ACCESSORIES TO BE INSTALLED PER THAT MANUFACTURER'S STANDARDS.
3. IF OLD RAKE TRIM IS REMOVED, NEW RAKE TRIM MAY NEED TO EXTEND TO OLD TRIM LINE DUE TO WALL PANEL COLOR FADE.

Rake/Endwall (RE-03-T/T)

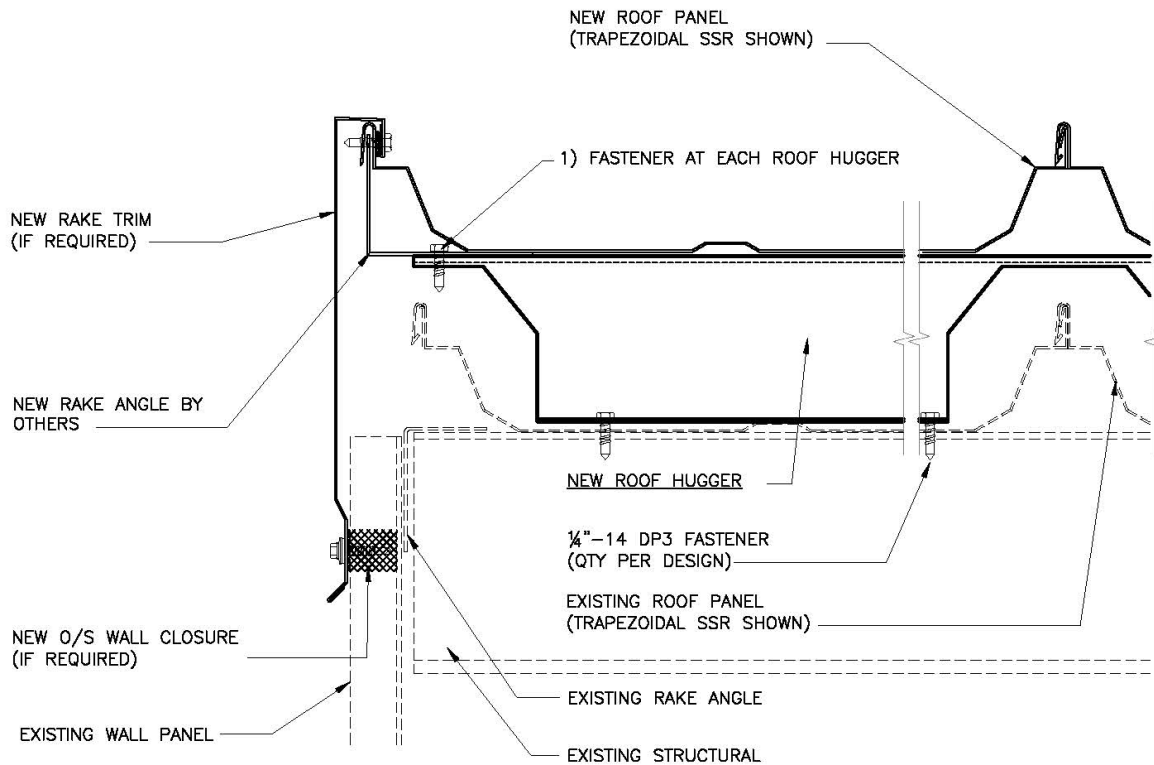

NOTES:

1. ALL FASTENERS NOT BY ROOF HUGGER UNLESS NOTED OTHERWISE.
2. ALL NEW ROOF SYSTEMS INCLUDING PANEL, FASTENERS, TRIM AND ACCESSORIES TO BE INSTALLED PER THAT MANUFACTURER'S STANDARDS.
3. IF OLD RAKE TRIM IS REMOVED, NEW RAKE TRIM MAY NEED TO EXTEND TO OLD TRIM LINE DUE TO WALL PANEL COLOR FADE.

Rake/Endwall (RE-04-V/R)

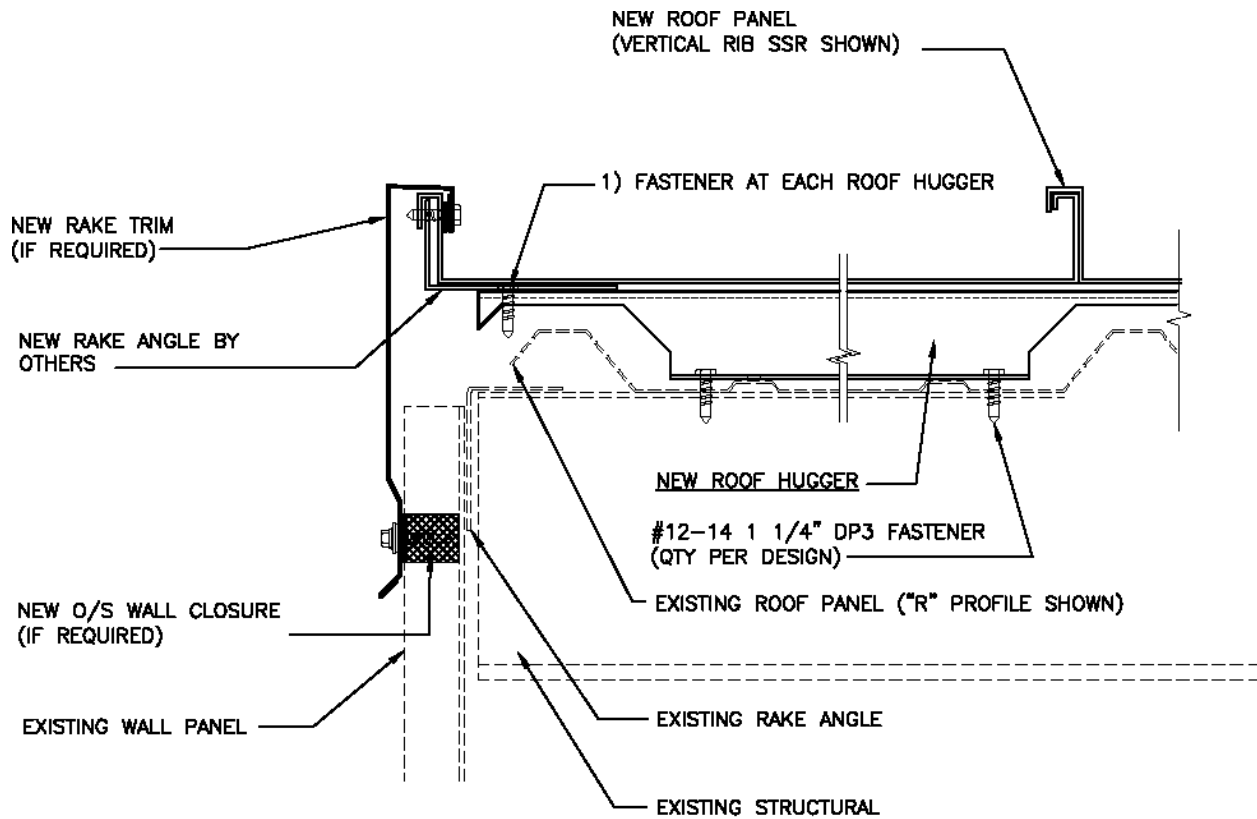

NOTES:

1. ALL FASTENERS NOT BY ROOF HUGGER UNLESS NOTED OTHERWISE.
2. ALL NEW ROOF SYSTEMS INCLUDING PANEL, FASTENERS, TRIM AND ACCESSORIES TO BE INSTALLED PER THAT MANUFACTURER'S STANDARDS.
3. IF OLD RAKE TRIM IS REMOVED, NEW RAKE TRIM MAY NEED TO EXTEND TO OLD TRIM LINE DUE TO WALL PANEL COLOR FADE.

Rake/Endwall (RE-05-V/V)

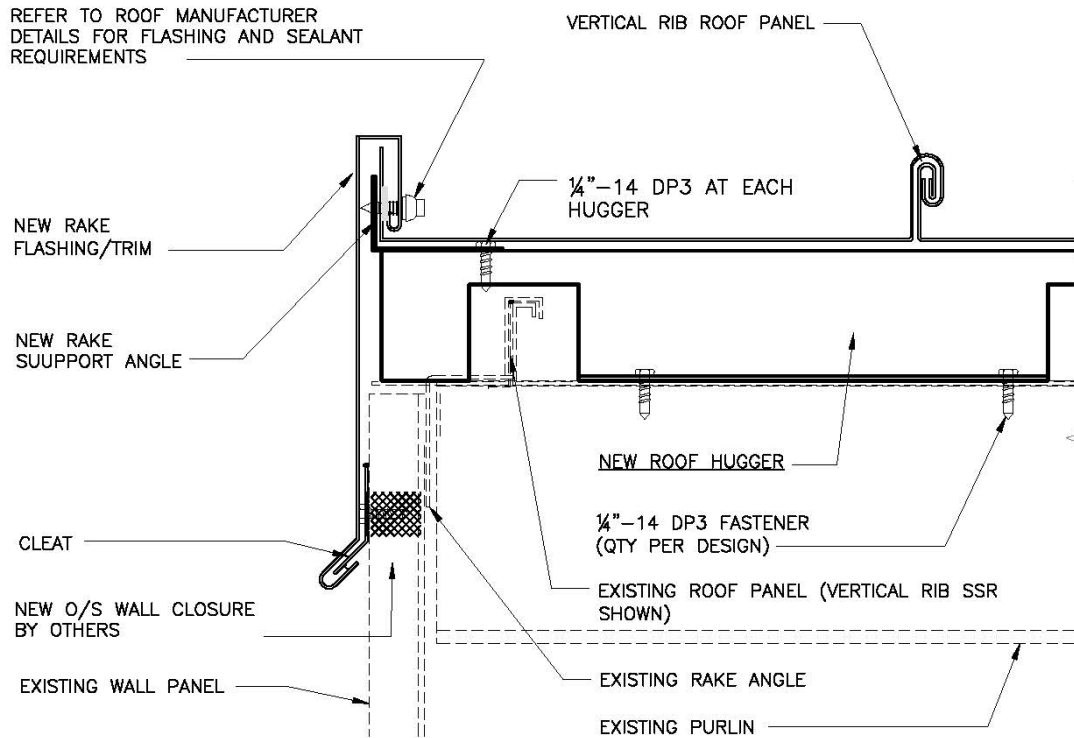

NOTES:

1. ALL FASTENERS NOT BY ROOF HUGGER UNLESS NOTED OTHERWISE.
2. ALL NEW ROOF SYSTEMS INCLUDING PANEL, FASTENERS, TRIM AND ACCESSORIES TO BE INSTALLED PER THAT MANUFACTURER'S STANDARDS.

Rake/Endwall (RE-06-V/T)

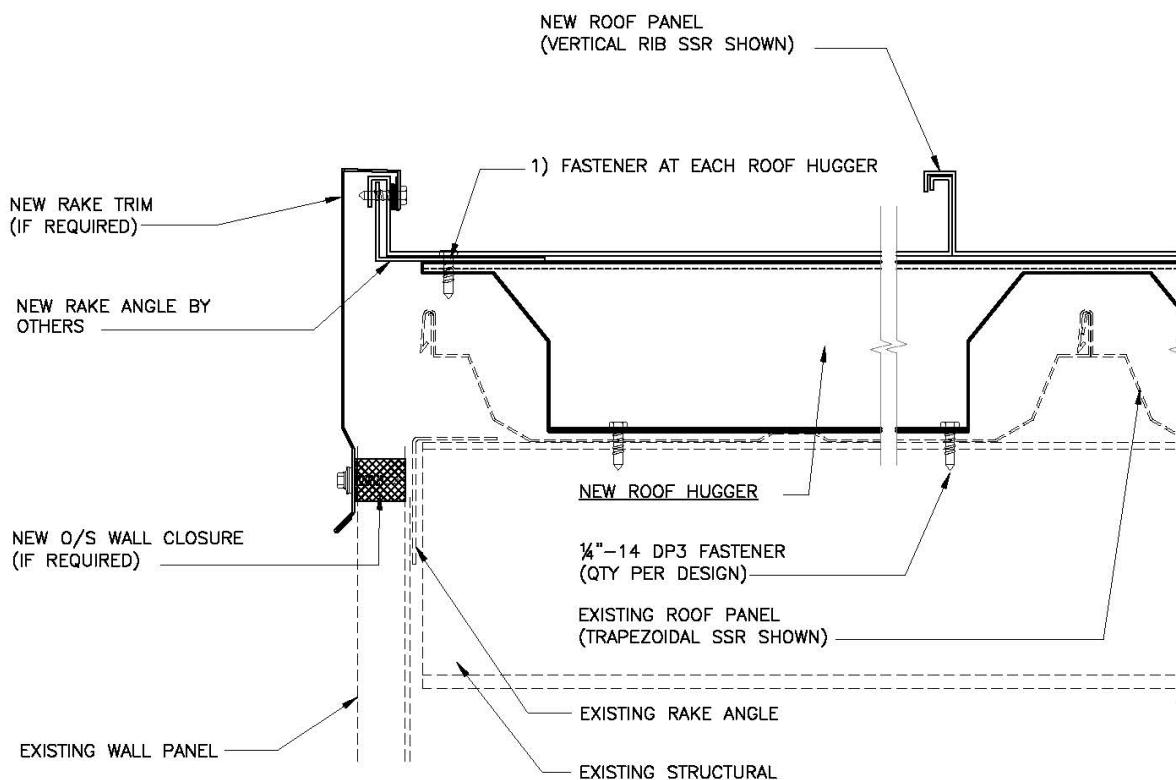

NOTES:

1. ALL FASTENERS NOT BY ROOF HUGGER UNLESS NOTED OTHERWISE.
2. ALL NEW ROOF SYSTEMS INCLUDING PANEL, FASTENERS, TRIM AND ACCESSORIES TO BE INSTALLED PER THAT MANUFACTURER'S STANDARDS.
3. IF OLD RAKE TRIM IS REMOVED, NEW RAKE TRIM MAY NEED TO EXTEND TO OLD TRIM LINE DUE TO WALL PANEL COLOR FADE.

Ridge (RD-01-G)

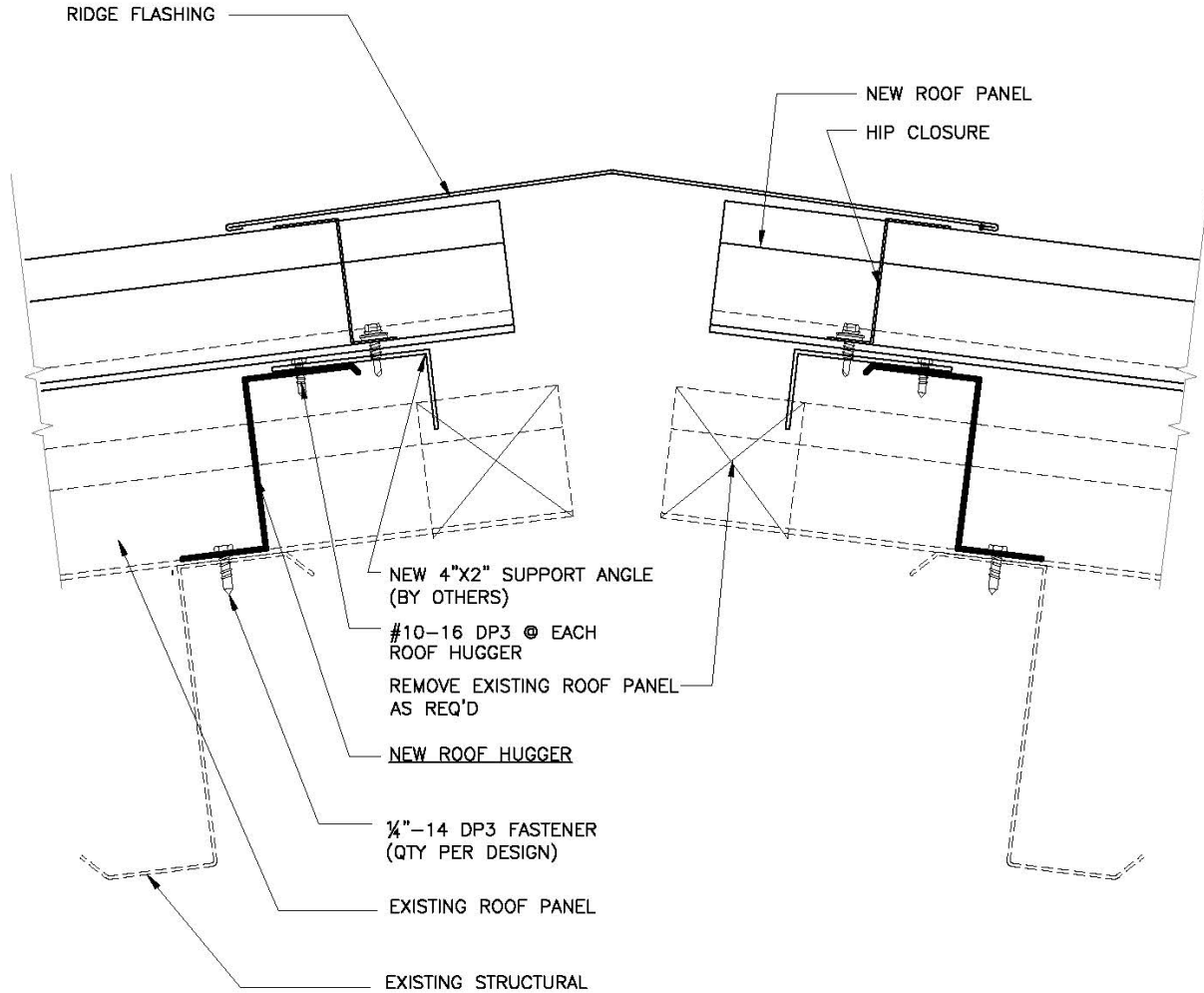

NOTES:

1. ALL FASTENERS NOT BY ROOF HUGGER UNLESS NOTED OTHERWISE.
2. ALL NEW ROOF SYSTEMS INCLUDING PANEL, FASTENERS, TRIM AND ACCESSORIES TO BE INSTALLED PER THAT MANUFACTURER'S STANDARDS.

Ridge – Vented (RD-02-GV)

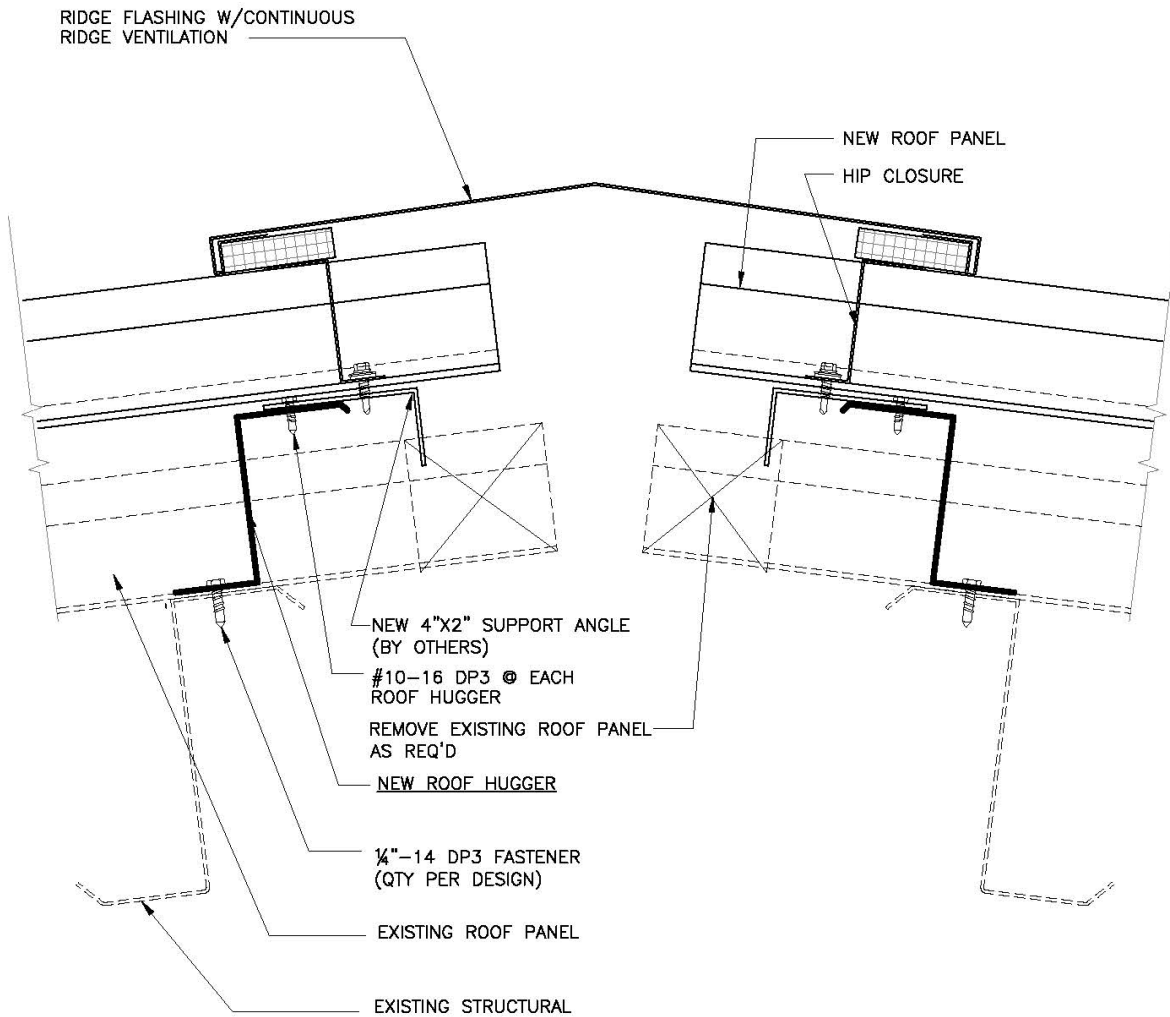

NOTES:

1. ALL FASTENERS NOT BY ROOF HUGGER UNLESS NOTED OTHERWISE.
2. ALL NEW ROOF SYSTEMS INCLUDING PANEL, FASTENERS, TRIM AND ACCESSORIES TO BE INSTALLED PER THAT MANUFACTURER'S STANDARDS.

Hip (HP-01-G)

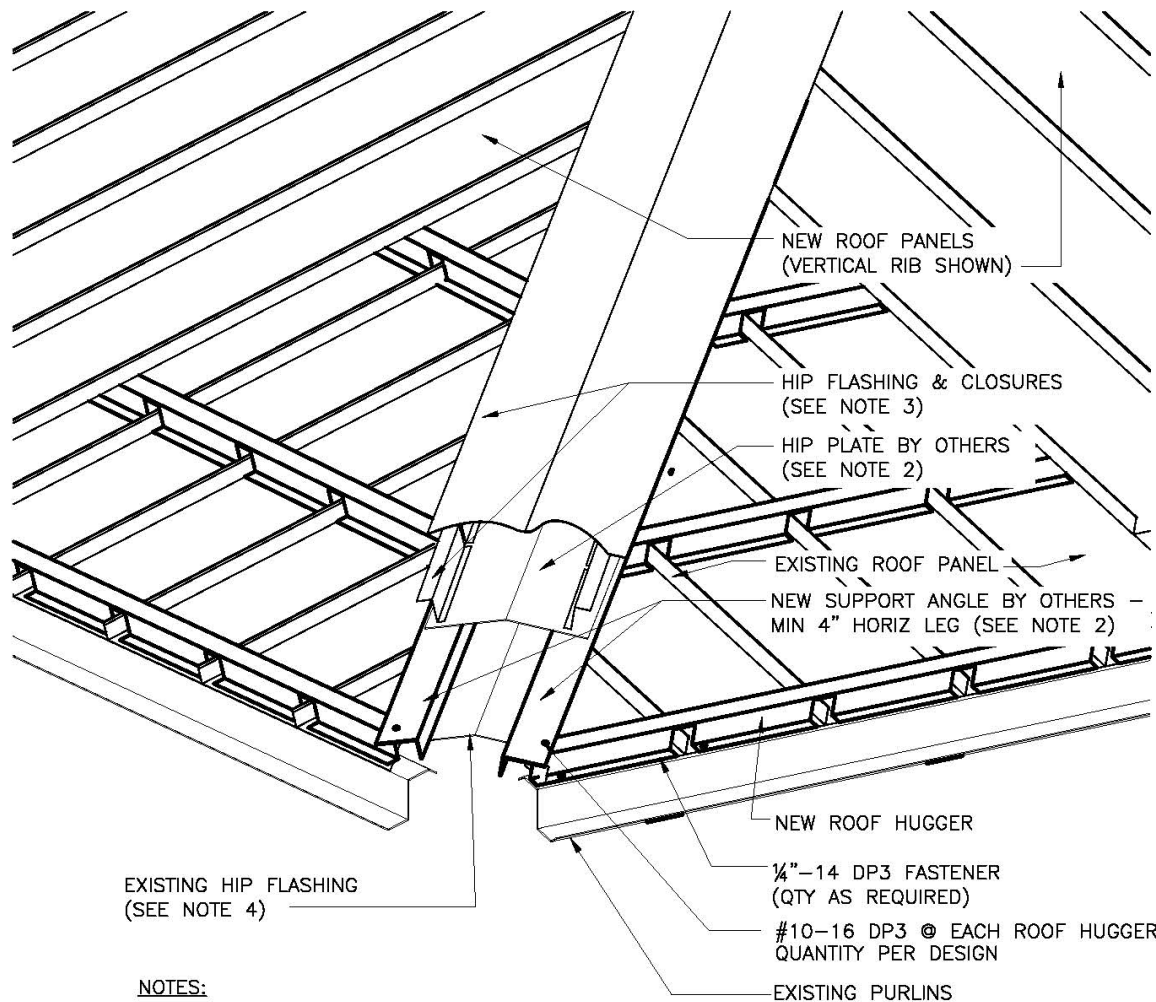

NOTES:

1. ALL FASTENERS NOT BY ROOF HUGGER UNLESS NOTED OTHERWISE
2. ROOF HUGGER SETBACK SUBJECT TO NEW ROOF PANEL REQUIREMENTS, CHECK WITH PANEL MANUFACTURER.
3. ALL NEW ROOF SYSTEMS INCLUDING PANEL, FASTENERS, TRIM AND ACCESSORIES TO BE INSTALLED PER THAT MANUFACTURER'S STANDARDS.
4. REMOVE EXISTING HIP FLASHING AND ROOF PANEL TO INSTALL ANGLES AS REQUIRED
5. SEE HP-02-G FOR CROSS SECTION VIEW

Valley (VL-01-G)

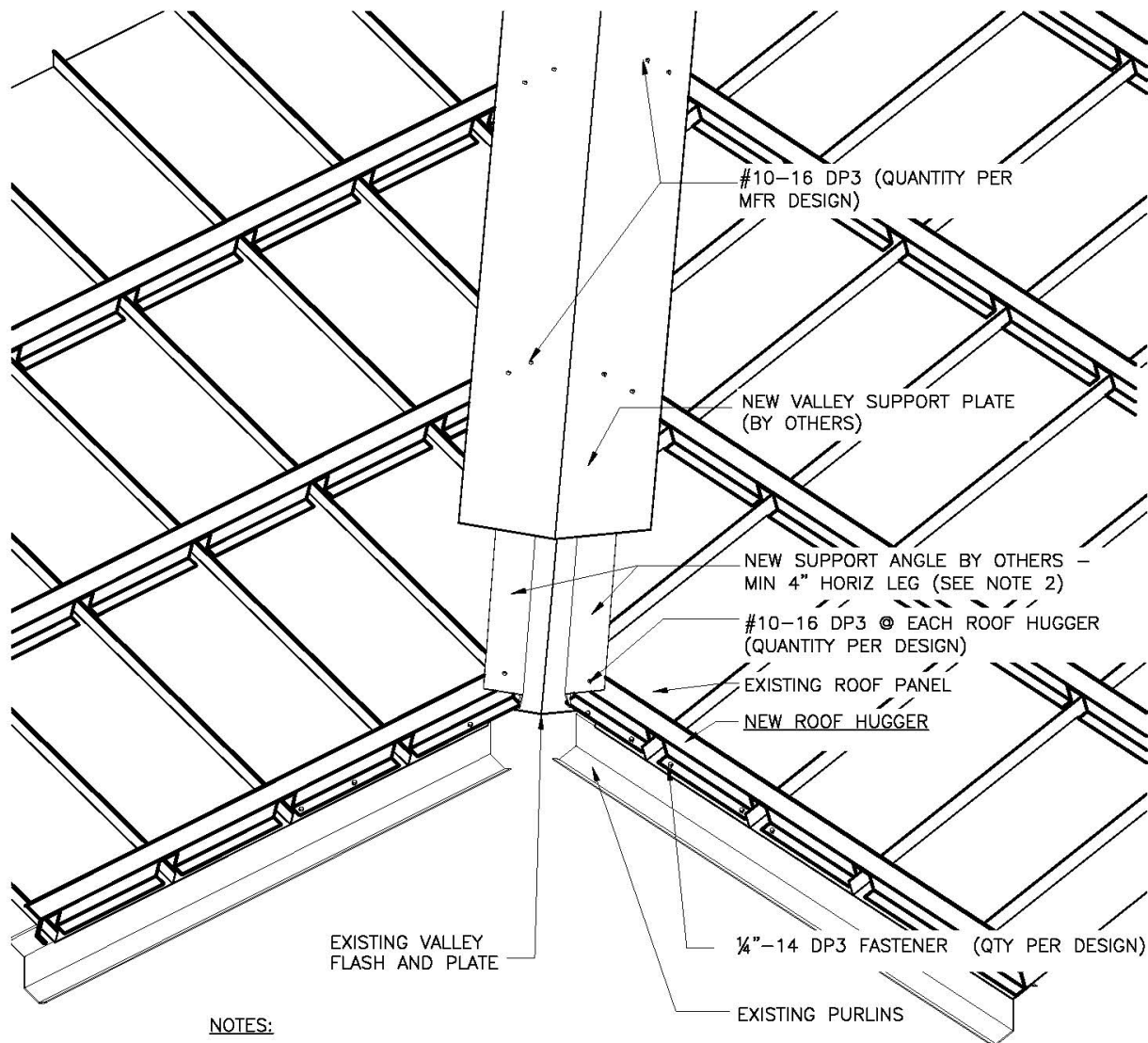

NOTES:

1. ALL FASTENERS NOT BY ROOF HUGGER UNLESS NOTED OTHERWISE
2. ROOF HUGGER SETBACK SUBJECT TO NEW ROOF PANEL REQUIREMENTS, CHECK WITH MANUFACTURER.
3. ALL NEW ROOF SYSTEMS INCLUDING PANEL, FASTENERS, TRIM AND ACCESSORIES TO BE INSTALLED PER THAT MANUFACTURER'S STANDARDS.
4. NEW ROOF PANELS NOT SHOWN FOR CLARITY.
5. SEE VL-02-G FOR CROSS SECTION VIEW

Valley (VL-02-G)

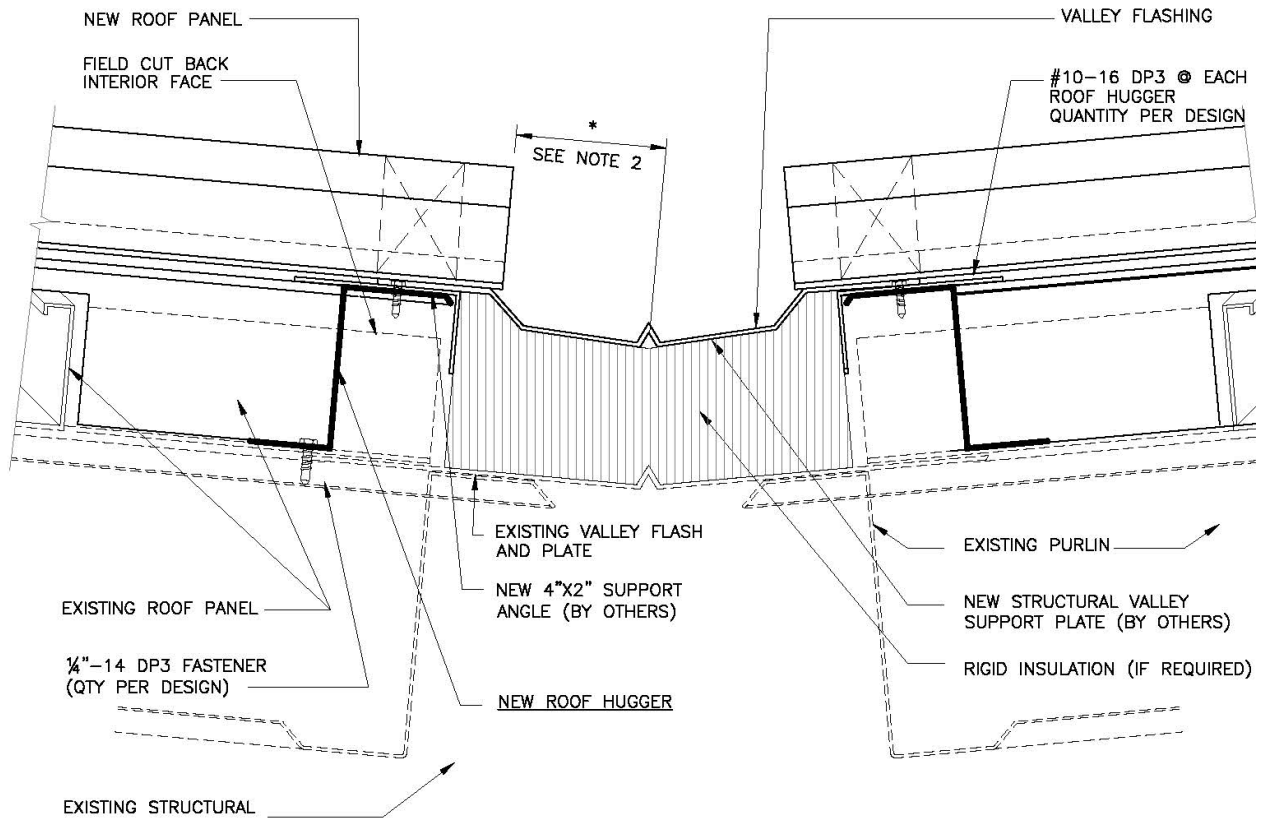

NOTES:

1. ALL FASTENERS NOT BY ROOF HUGGER UNLESS NOTED OTHERWISE
2. ROOF HUGGER SETBACK SUBJECT TO NEW ROOF PANEL REQUIREMENTS, CHECK WITH MANUFACTURER.
3. ALL NEW ROOF SYSTEMS INCLUDING PANEL, FASTENERS, TRIM AND ACCESSORIES TO BE INSTALLED PER THAT MANUFACTURER'S STANDARDS.
4. SEE VL-01-G FOR ISOMETRIC VIEW.

Valley Gutter (VG-01-G)

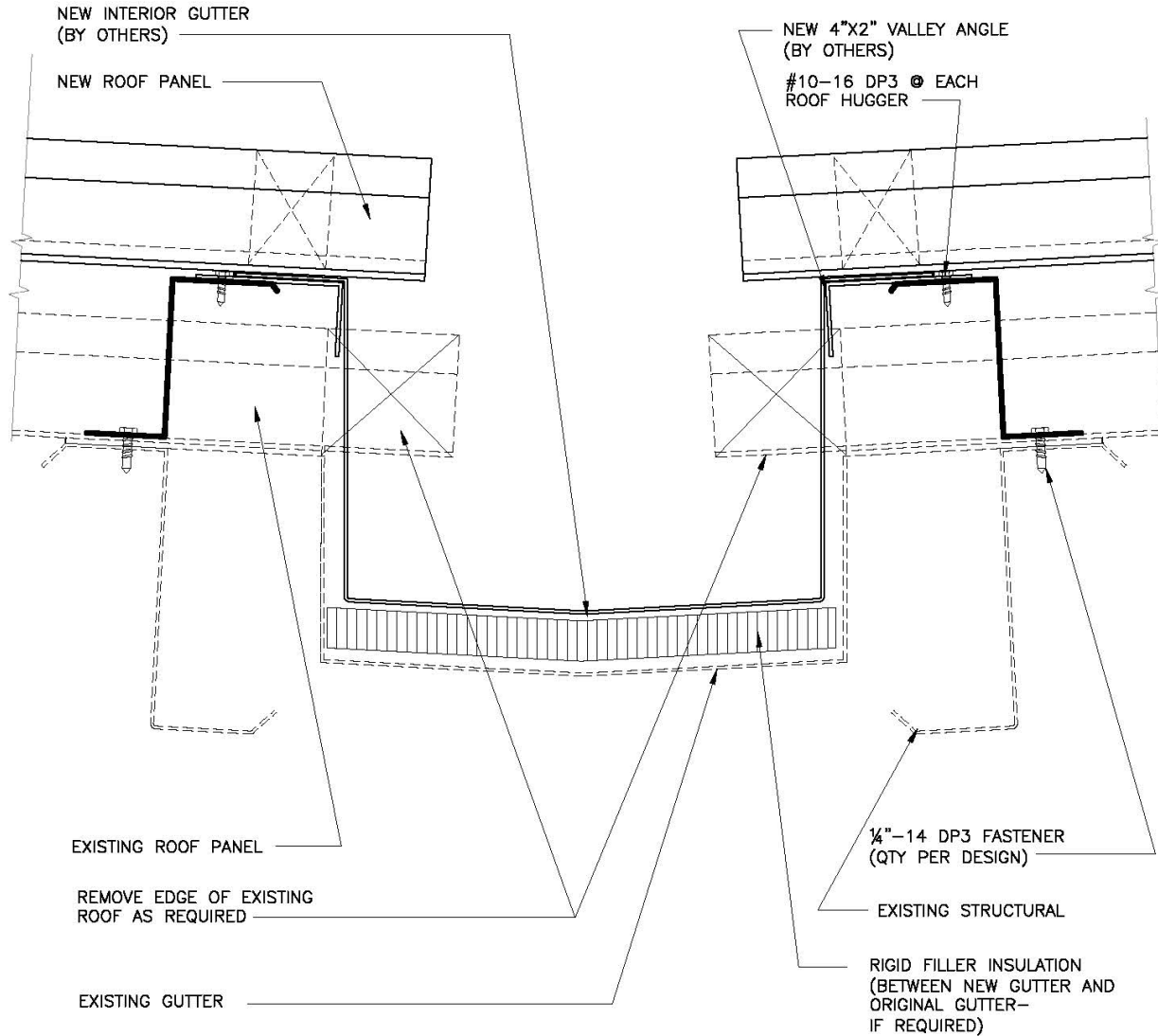

NOTES:

1. ALL FASTENERS NOT BY ROOF HUGGER UNLESS NOTED OTHERWISE.
2. ALL NEW ROOF SYSTEMS INCLUDING PANEL, FASTENERS, TRIM AND ACCESSORIES TO BE INSTALLED PER THAT MANUFACTURER'S STANDARDS.

Lean-to Step (LT-01-G)

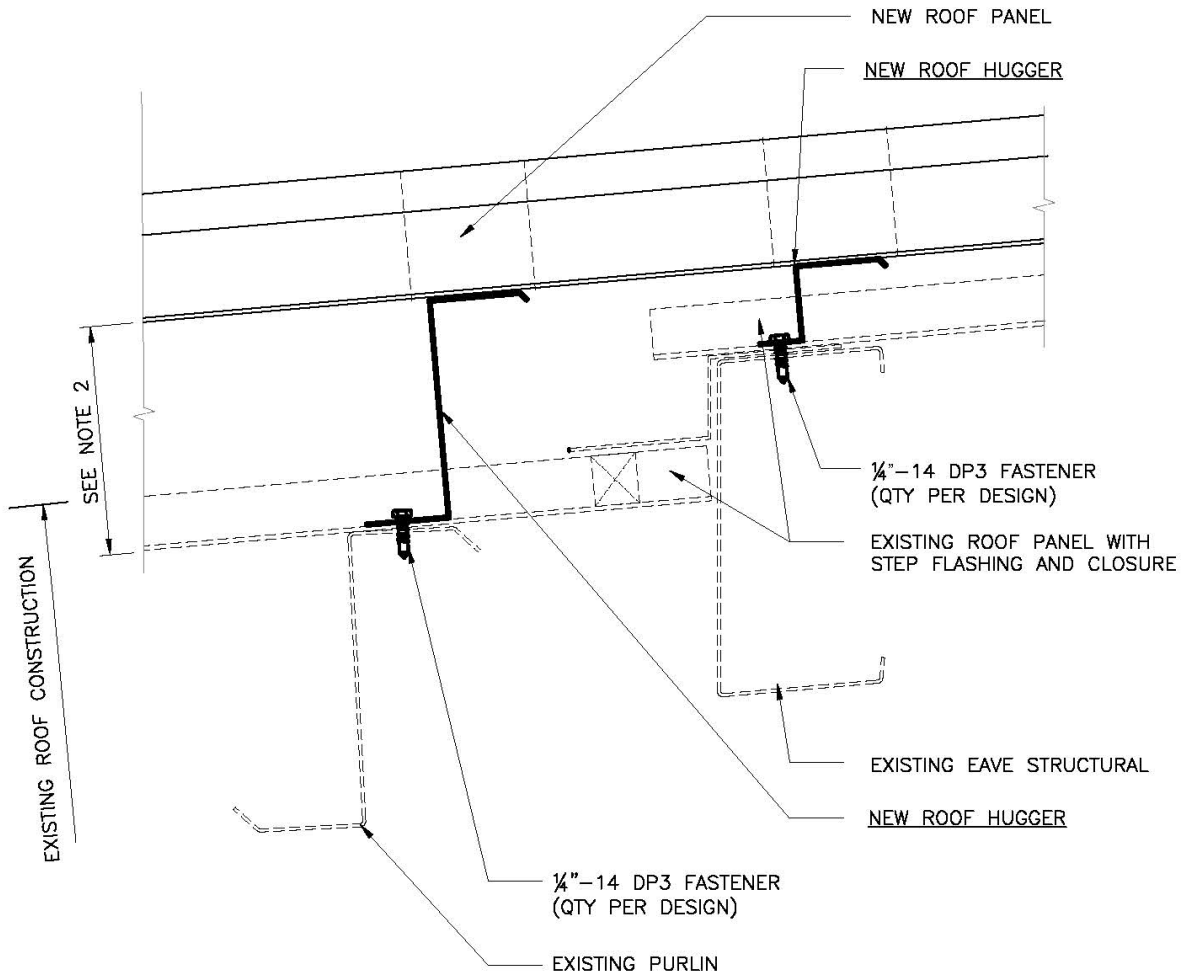

NOTES:

1. ALL FASTENERS NOT BY ROOF HUGGER UNLESS NOTED OTHERWISE
2. CONSULT WITH ROOF HUGGER FOR MAXIMUM HEIGHT.
3. ALL NEW ROOF SYSTEMS INCLUDING PANEL, FASTENERS, TRIM AND ACCESSORIES TO BE INSTALLED PER THAT MANUFACTURER'S STANDARDS.

Pitchbreak/Roof-to-Wall (PB-01-G)

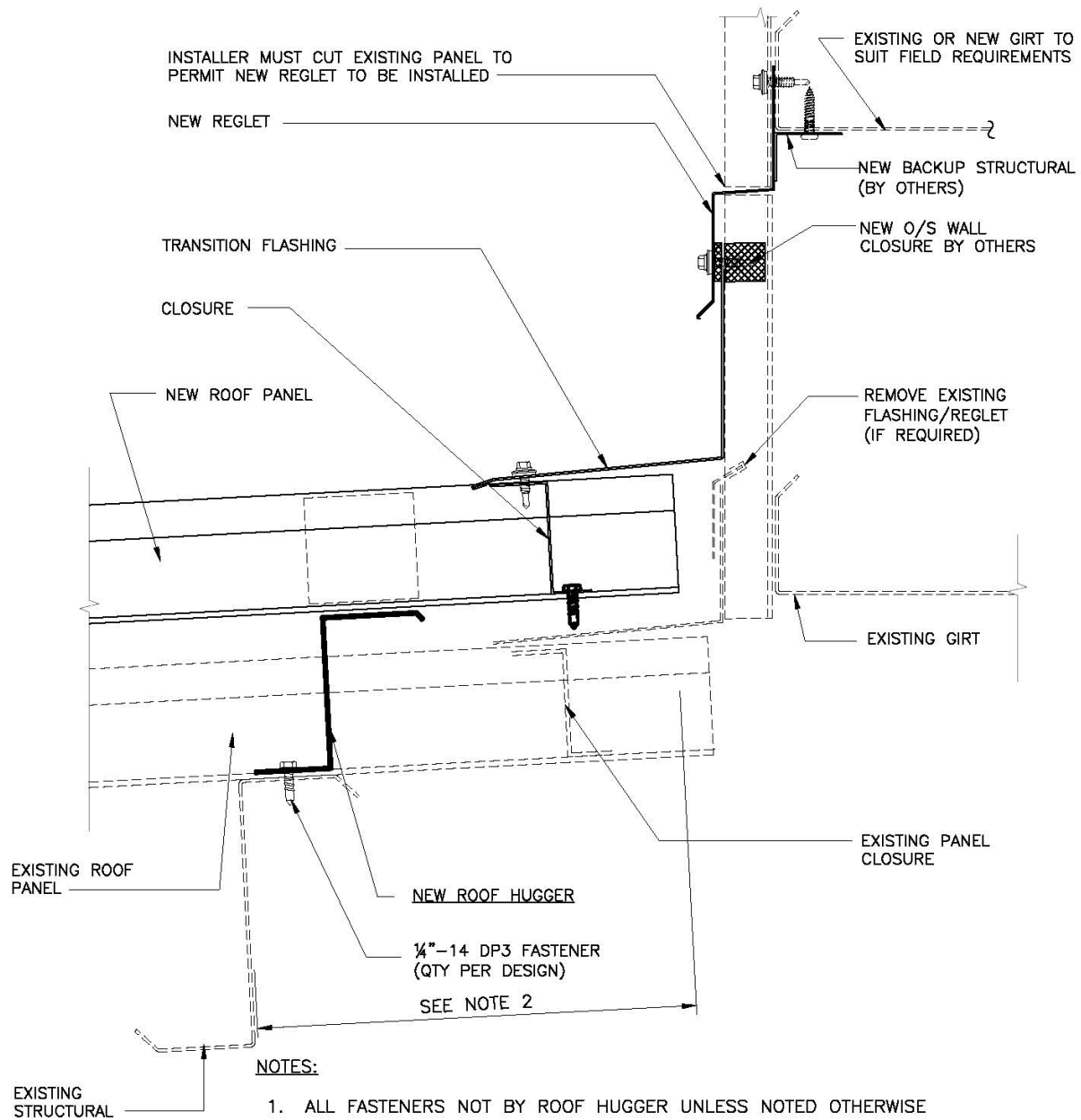

1. ALL FASTENERS NOT BY ROOF HUGGER UNLESS NOTED OTHERWISE
2. ROOF HUGGER SETBACK SUBJECT TO NEW ROOF PANEL REQUIREMENTS, CHECK WITH PANEL MANUFACTURER.
3. ALL NEW ROOF SYSTEMS INCLUDING PANEL, FASTENERS, TRIM AND ACCESSORIES TO BE INSTALLED PER THAT MANUFACTURER'S STANDARDS.

Rake-to-Wall (RW-01-T/R)

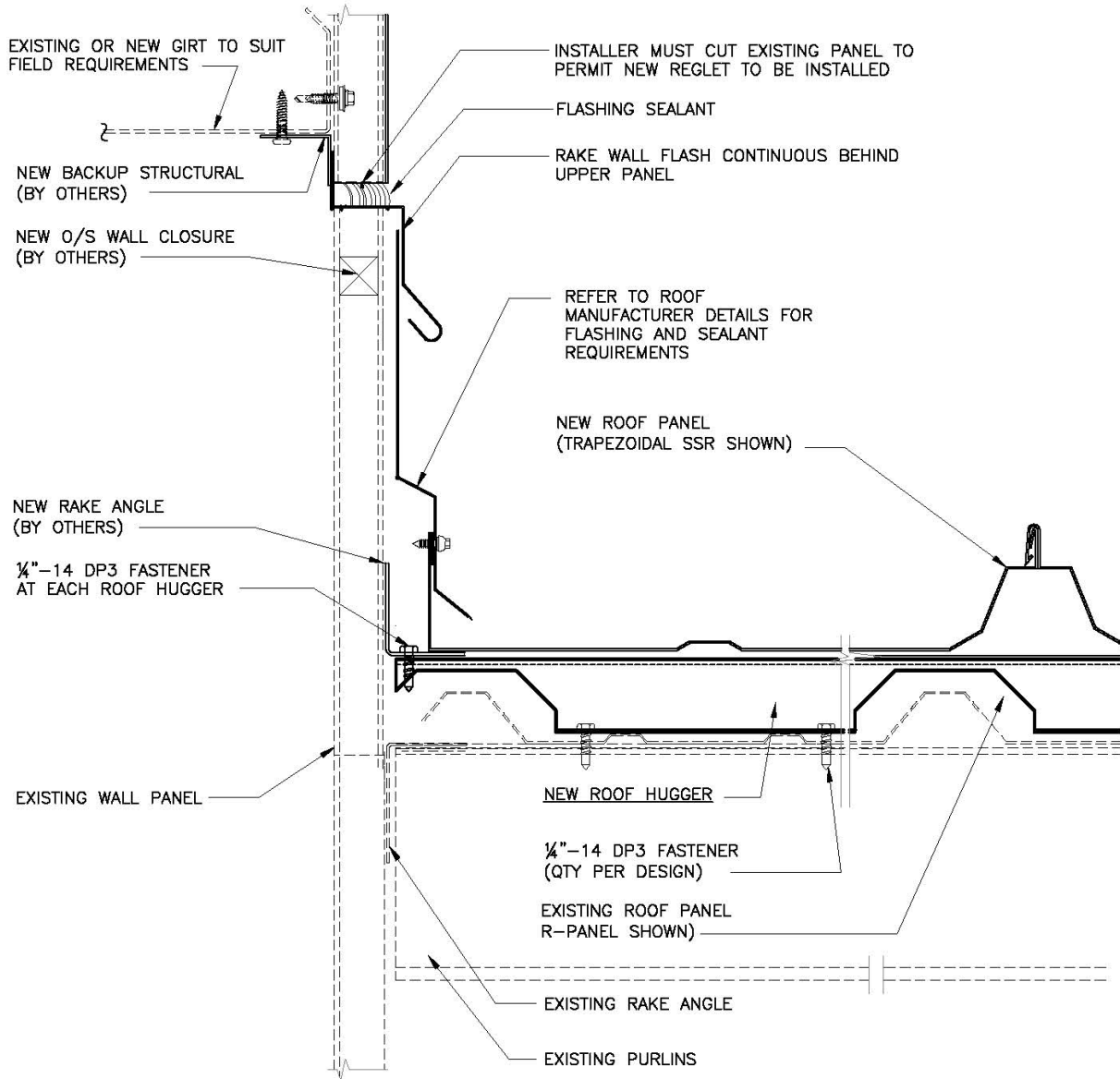

NOTES:

1. ALL FASTENERS NOT BY ROOF HUGGER UNLESS NOTED OTHERWISE.
2. ALL NEW ROOF SYSTEMS INCLUDING PANEL, FASTENERS, TRIM AND ACCESSORIES TO BE INSTALLED PER THAT MANUFACTURER'S STANDARDS.

Rake-to-Wall (RW-02-T/T)

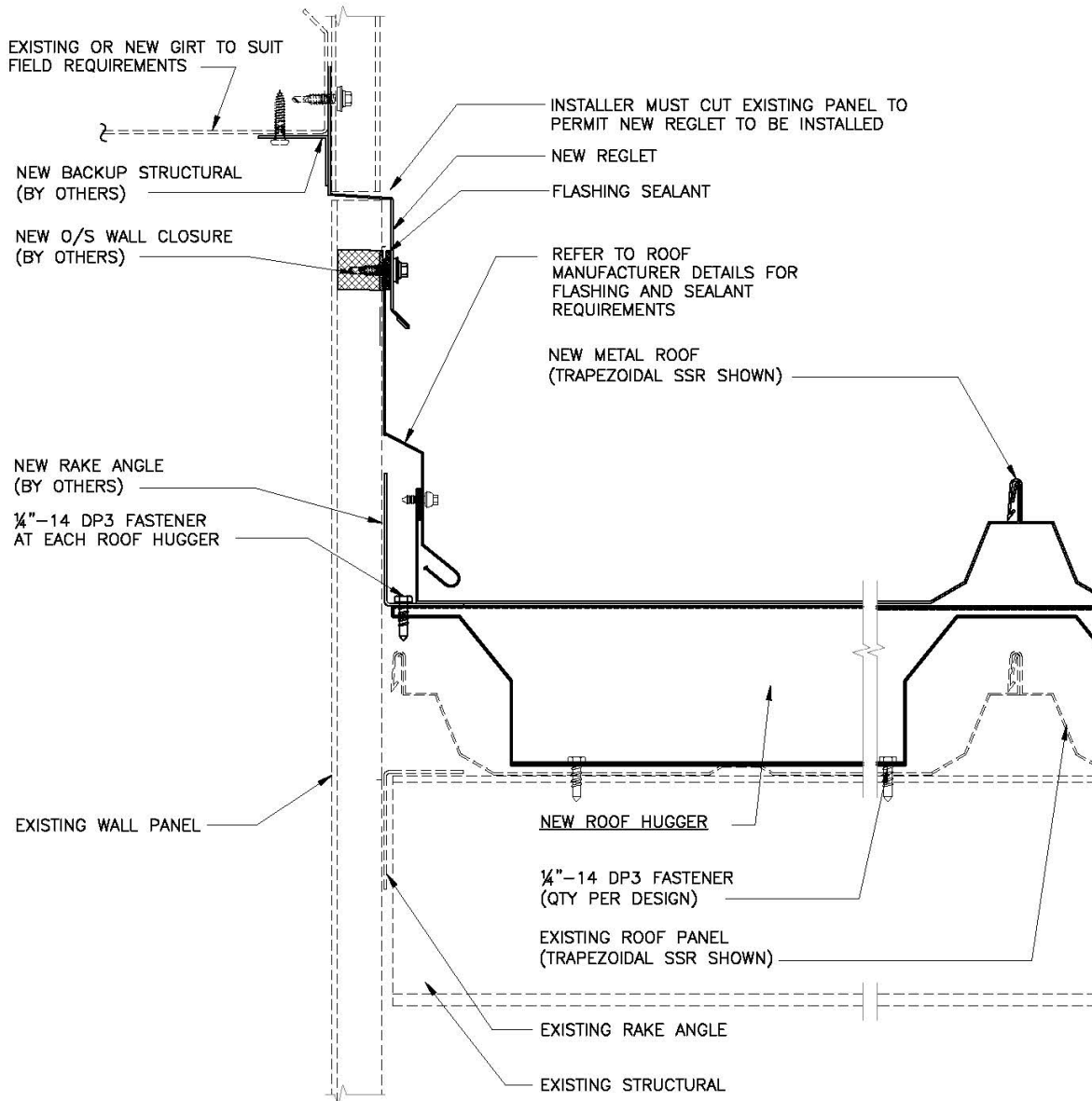

NOTES:

1. ALL FASTENERS NOT BY ROOF HUGGER UNLESS NOTED OTHERWISE.
2. ALL NEW ROOF SYSTEMS INCLUDING PANEL, FASTENERS, TRIM AND ACCESSORIES TO BE INSTALLED PER THAT MANUFACTURER'S STANDARDS.

Rake-to-Wall (RW-03-T/V)

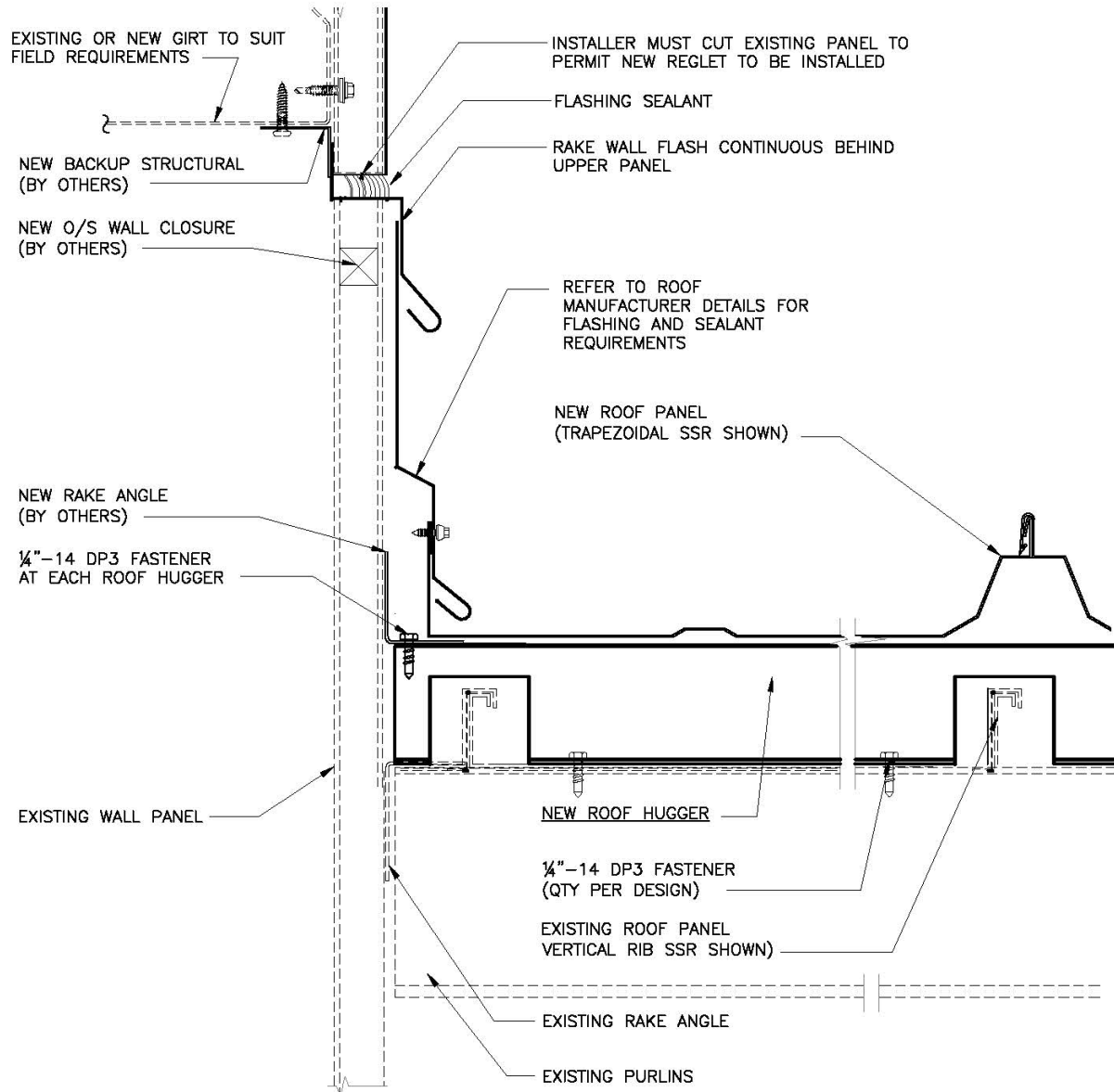

NOTES:

1. ALL FASTENERS NOT BY ROOF HUGGER UNLESS NOTED OTHERWISE.
2. ALL NEW ROOF SYSTEMS INCLUDING PANEL, FASTENERS, TRIM AND ACCESSORIES TO BE INSTALLED PER THAT MANUFACTURER'S STANDARDS.

Rake-to-Wall (RW-04-V/R)

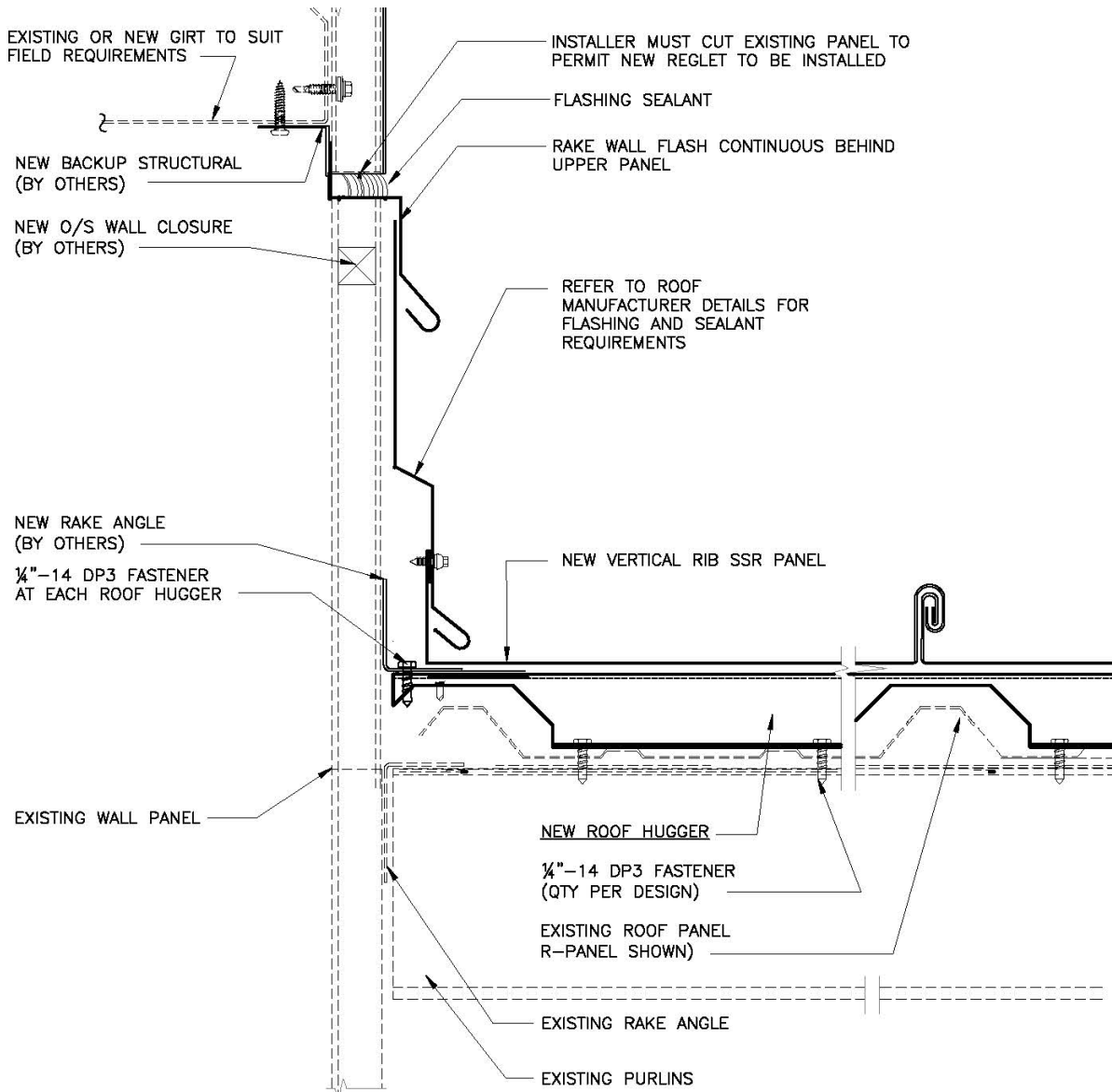

NOTES:

1. ALL FASTENERS NOT BY ROOF HUGGER UNLESS NOTED OTHERWISE.
2. ALL NEW ROOF SYSTEMS INCLUDING PANEL, FASTENERS, TRIM AND ACCESSORIES TO BE INSTALLED PER THAT MANUFACTURER'S STANDARDS.

Rake-to-Wall (RW-05-V/V)

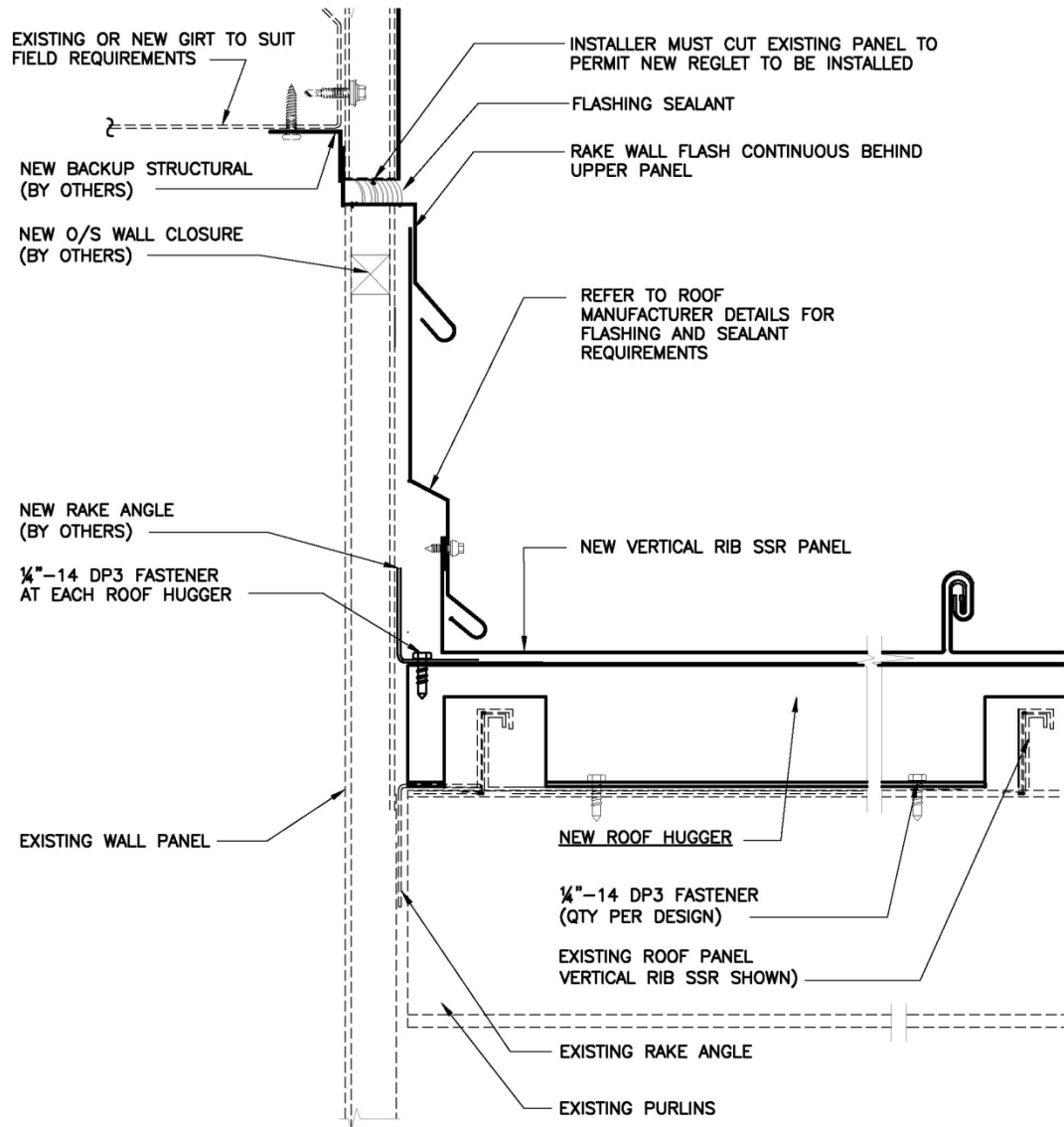

NOTES:

1. ALL FASTENERS NOT BY ROOF HUGGER UNLESS NOTED OTHERWISE.
2. ALL NEW ROOF SYSTEMS INCLUDING PANEL, FASTENERS, TRIM AND ACCESSORIES TO BE INSTALLED PER THAT MANUFACTURER'S STANDARDS.

Rake-to-Wall (RW-06-V/T)

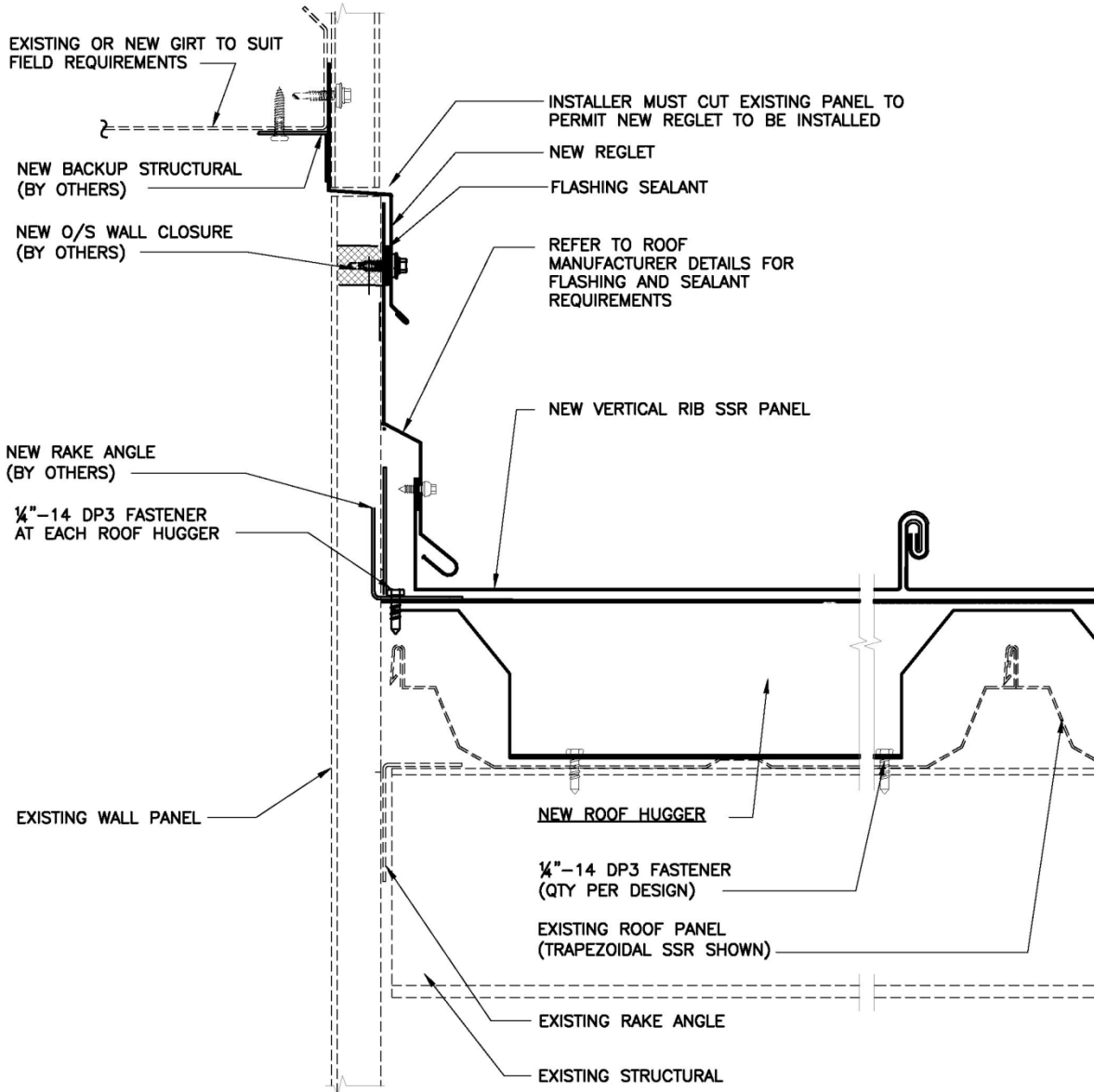

NOTES:

1. ALL FASTENERS TO BE INSTALLED PER HUGGER UNLESS NOTED OTHERWISE.
2. ALL NEW ROOF SYSTEMS INCLUDING PANEL, FASTENERS, TRIM AND ACCESSORIES TO BE INSTALLED PER THAT MANUFACTURER'S STANDARDS.

Panel Expansion Joint (EJ-01-T/R)

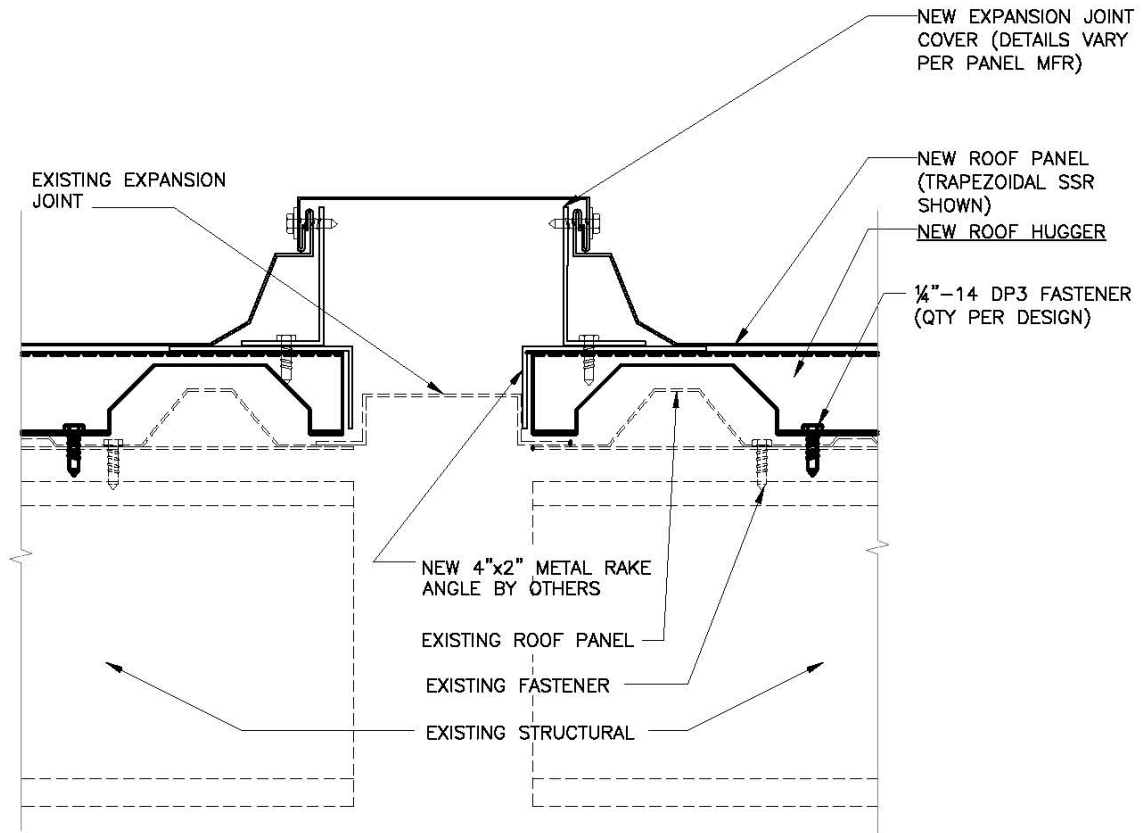

NOTES:

1. ALL FASTENERS NOT BY ROOF HUGGER UNLESS NOTED OTHERWISE.
2. ALL NEW ROOF SYSTEMS INCLUDING PANEL, FASTENERS, TRIM AND ACCESSORIES TO BE INSTALLED PER THAT MANUFACTURER'S STANDARDS.

Insulated Assemblies (01-1B-R/R)

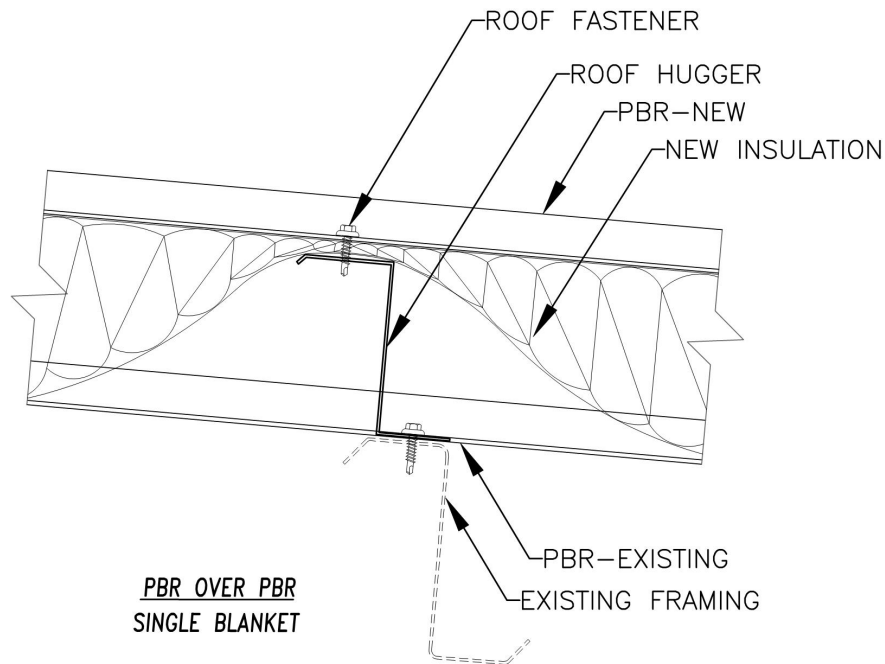

System		PBR over PBR - Single Blanket					UNFACED Blanket Thickness Combination Used
Roof Hugger Web Depth in Inches	Maximum Cavity Depth in Inches	Initial Insulation Thickness in Inches	Estimated R- Value	Estimated U- Value	Thermal Spacer Thickness in Inches		
1.83	2.018	3.00	6.52	0.153	n/a	3.00" blanket over purlins; 3/16" used as max. compression	
2.75	3.000	3.00	9.32	0.107	n/a	3.30" blanket over purlins; 1/4" used as max. compression	
Compressed Insulation R-Values have been calculated from a published method of the North American Insulation Manufacturers Association™ (NAIMA™).							
Insulation R-Value calculated based on published industry information from NAIMA™, CertainTeed®, Johns Manville® or Owens Corning®.							
Due to variations in installation methods and metal roof/rib or seam configurations; calculated values shown herein do not compensate for thermal bridging or thermal loss from existing roof panel rib configuration.							
Calculated R-Values shown herein do not take credit for air film effects or use of vapor barriers within the insulation system.							

Insulated Assemblies (02-2B-R/R)

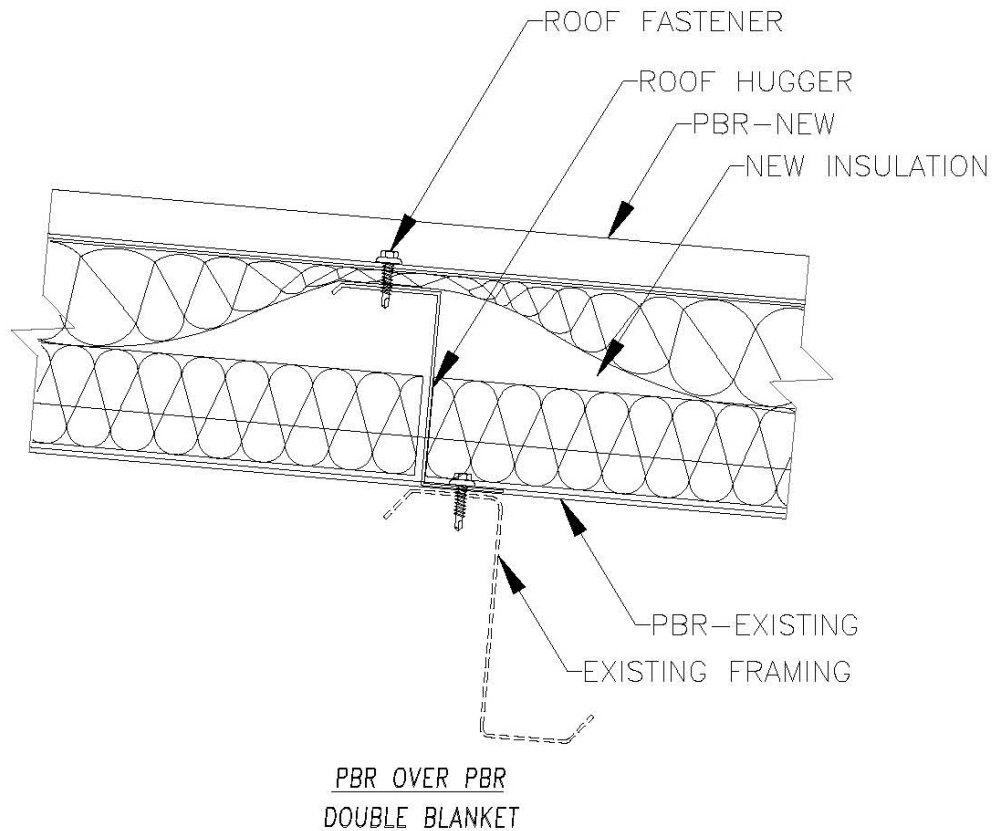

System	PBR over PBR - Double Blanket					
Roof Hugger Web Depth in Inches	Maximum Cavity Depth in Inches	Initial Insulation Thickness in Inches	Estimated R- Value	Estimated U- Value	Thermal Spacer Thickness in Inches	UNFACED Blanket Thickness Combination Used
3.75	4.000	5.50	12.94	0.077	n/a	2.75" blanket over purlins; 1/4" used as max. compression; 2.75" blanket between purlins
4.50	4.750	5.50	13.78	0.073	n/a	2.75" blanket over purlins; 1/4" used as max. compression; 2.75" blanket between purlins
Compressed insulation R-Values have been calculated from a published method of the North American Insulation Manufacturers Association™ (NAIMA™).						
Insulation R-Value calculated based on published industry information from NAIMA™, CertainTeed®, Johns Manville® or Owens Corning®.						
Due to variations in installation methods and metal roof rib or seam configurations; calculated values shown herein do not compensate for thermal bridging or thermal loss from existing roof panel rib configuration.						
Calculated R-Values shown herein do not take credit for air film effects or use of vapor barriers within the insulation system.						

Insulated Assemblies (03-1B-S/R)

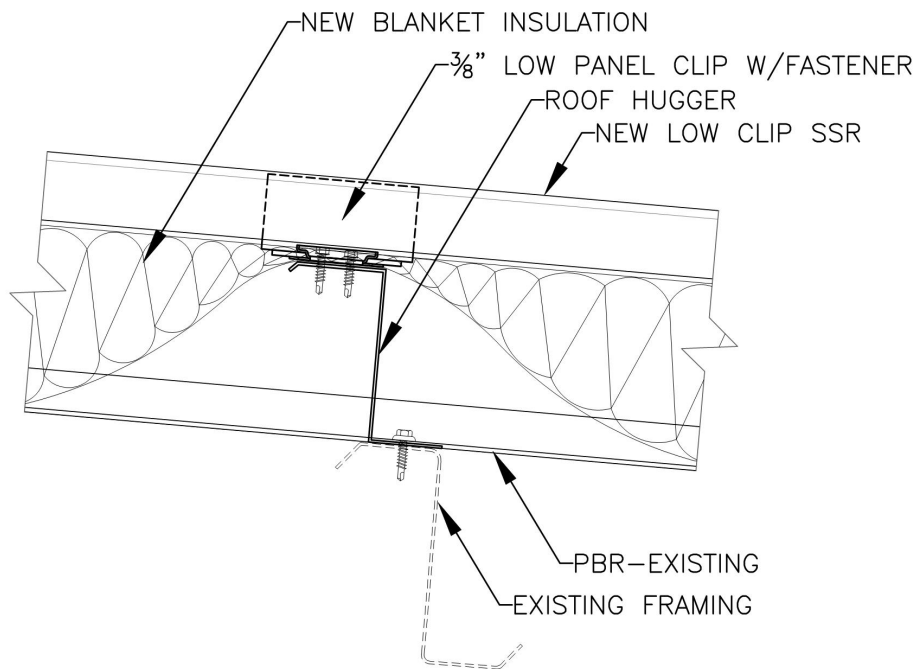

3/8" LOW CLIP W/NO THERMAL SPACER SSR OVER PBR
SINGLE BLANKET

System	3/8" Low Clip SSR Over PBR Panel - Single Blanket					
Roof Hugger Web Depth in Inches	Maximum Cavity Depth in Inches	Initial Insulation Thickness in Inches	Estimated R- Value	Estimated U- Value	Thermal Spacer Thickness in Inches	UNFACED Blanket Thickness Combination Used
1.83	2.830	3.00	6.81	0.147	0	3.0" blanket over purlins no thermal spacer
2.75	3.750	4.00	10.2	0.098	0	4.0" blanket over purlins no thermal spacer

Compressed insulation R-Values have been calculated from a published method of the North American Insulation Manufacturers Association™ (NAIMA™).

Insulation R-Value calculated based on published industry information from NAIMA™, CertainTeed®, Johns Manville® or Owens Corning®.

Due to variations in installation methods and metal roof rib or seam configurations; calculated values shown herein do not compensate for thermal bridging or thermal loss from existing roof panel rib configuration.

Calculated R-Values shown herein do not take credit for air film effects or use of vapor barriers within the insulation system.

Insulated Assemblies (04-2B-S/R)

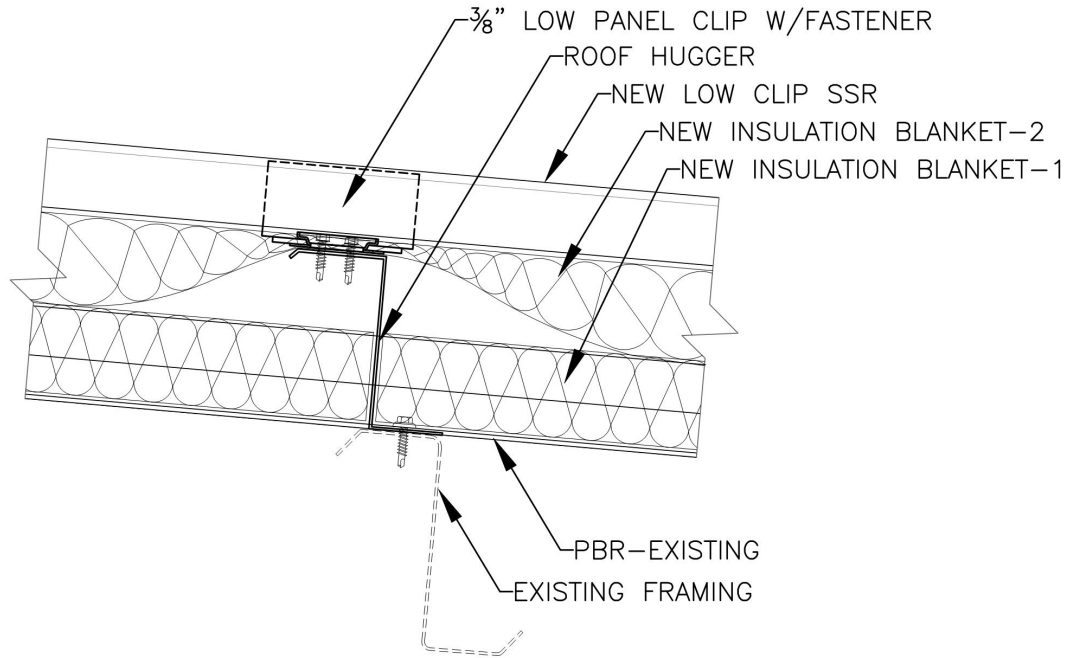

3/8" LOW CLIP W/ NO THERMAL SPACER SSR OVER PBR
DOUBLE BLANKET

System	3/8" Low Clip SSR Over PBR Panel - Double Blanket					
Roof Hugger Web Depth in Inches	Maximum Cavity Depth in Inches	Initial Insulation Thickness in Inches	Estimated R- Value	Estimated U- Value	Thermal Spacer Thickness in Inches	UNFACED Blanket Thickness Combination Used
3.75	4.125	5.50	16.22	0.062	0	2.75" blanket over purlins; 2.75" blanket between purlins
5.25	5.625	6.00	16.32	0.061	0	2.50" blanket over purlins; 3.50" blanket between purlins
7.50	7.875	8.00	23.56	0.042	0	4.0" blanket over purlins; 4.0" blanket between purlins
Compressed insulation R-Values have been calculated from a published method of the North American Insulation Manufacturers Association™ (NAIMA™).						
Insulation R-Value calculated based on published industry information from NAIMA™, CertainTeed®, Johns Manville® or Owens Corning®.						
Due to variations in installation methods and metal roofrib or seam configurations; calculated values shown herein do not compensate for thermal bridging or thermal loss from existing roof panel rib configuration.						
Calculated R-Values shown herein do not take credit for air film effects or use of vapor barriers within the insulation system.						

Insulated Assemblies (05-1B-S/T)

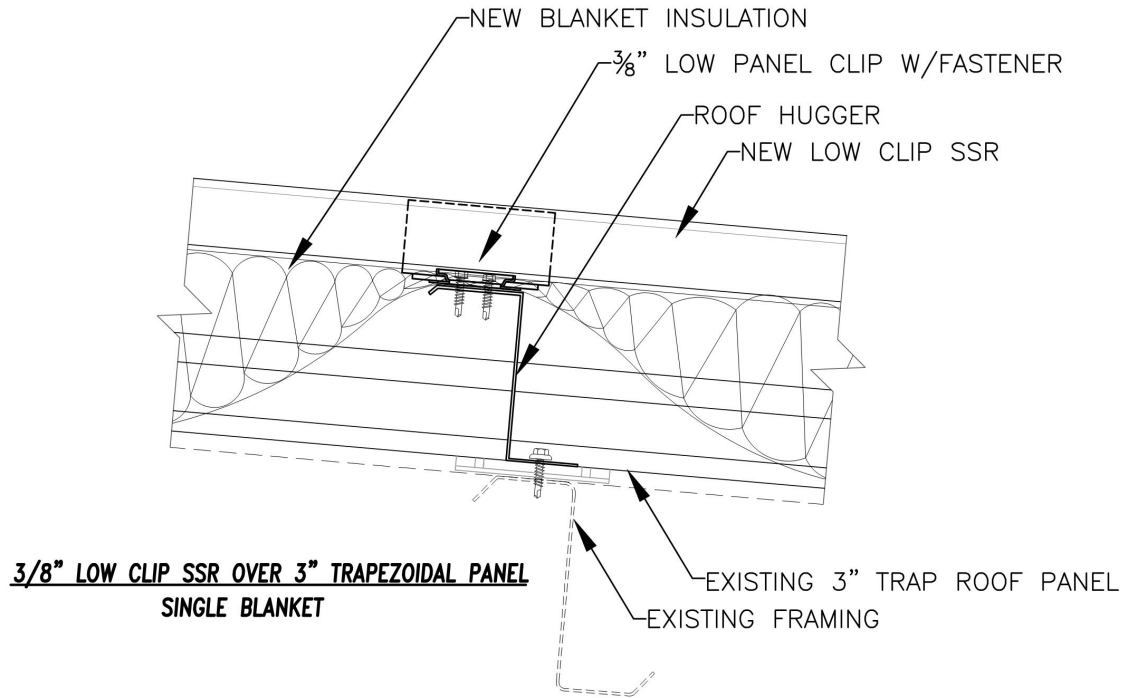

3/8" LOW CLIP SSR OVER 3" TRAPEZOIDAL PANEL
SINGLE BLANKET

System	3/8" Low Clip SSR over Low Clip 3" Trapezoidal SSR - Single Blanket					
Roof Hugger Web Depth in Inches	Maximum Cavity Depth in Inches	Initial Insulation Thickness in Inches	Estimated R- Value	Estimated U- Value	Thermal Spacer Thickness in Inches	Blanket Thickness Combination Used
4.50	4.875	6.00	14.42	0.069	0	6.0" unfaced blanket over purlins -no thermal spacer
Compressed insulation R-Values have been calculated from a published method of the North American Insulation Manufacturers Association™ (NAIMA™).						
Insulation R-Value calculated based on published industry information from NAIMA™, CertainTeed®, Johns Manville® or Owens Corning®.						
Due to variations in installation methods and metal roof rib or seam configurations; calculated values shown herein do not compensate for thermal bridging or thermal loss from existing roof panel rib configuration.						
Calculated R-Values shown herein do not take credit for air film effects or use of vapor barriers within the insulation system.						

Insulated Assemblies (06-2B-S/T)

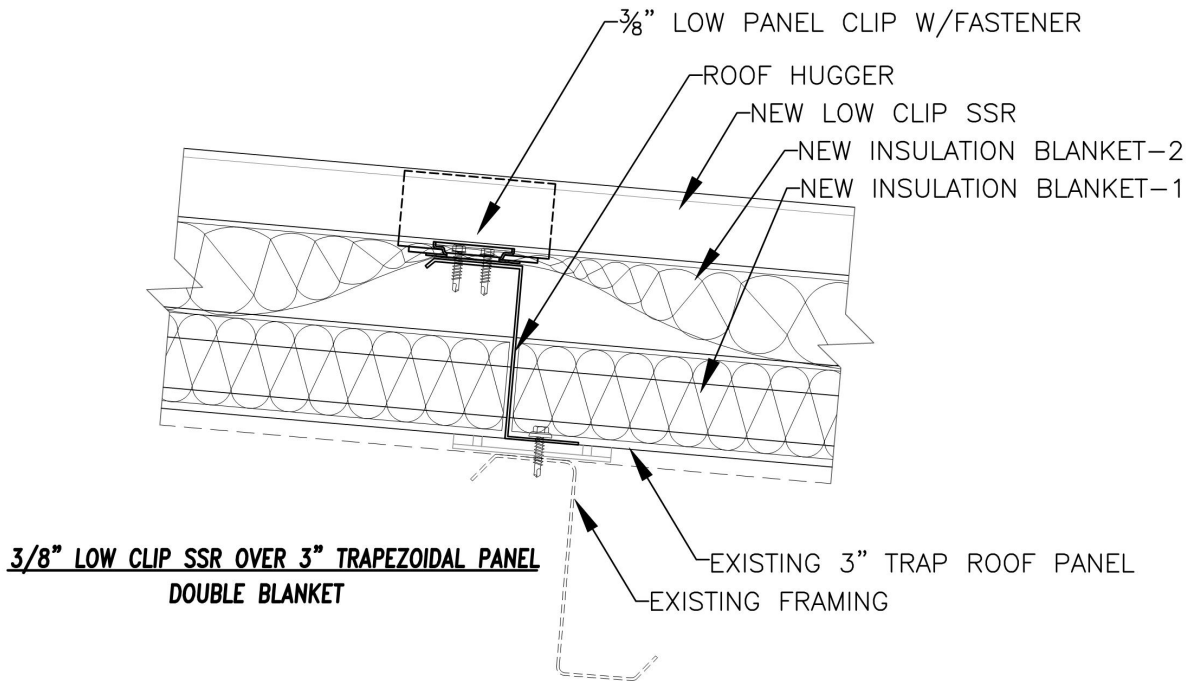

System	3/8" Low Clip SSR Over Low Clip 3" Trapezoidal SSR - Double Blanket					
Roof Hugger Web Depth in Inches	Maximum Cavity Depth in Inches	Initial Insulation Thickness in Inches	Estimated R- Value	Estimated U- Value	Thermal Spacer Thickness in Inches	UNFACED Blanket Thickness Combination Used
4.50	4.875	5.50	17.47	0.057	0	2.75" blanket over purlins; 2.75" blanket between purlins
5.50	5.875	6.00	20.12	0.050	0	3.0" blanket over purlins; 3.0" blanket between purlins
6.75	7.125	7.50	23.14	0.043	0	3.5" blanket over purlins; 4.0" blanket between purlins
7.50	7.875	8.00	23.56	0.042	0	4.0" blanket over purlins; 4.0" blanket between purlins

Compressed insulation R-Values have been calculated from a published method of the North American Insulation Manufacturers Association™ (NAIMA™).

Insulation R-Value calculated based on published industry information from NAIMA™, CertainTeed®, Johns Manville® or Owens Corning®.

Due to variations in installation methods and metal roof rib or seam configurations; calculated values shown herein do not compensate for thermal bridging or thermal loss from existing roof panel rib configuration.

Calculated R-Values shown herein do not take credit for air film effects or use of vapor barriers within the insulation system.

Insulated Assemblies (07-1B-S/V)

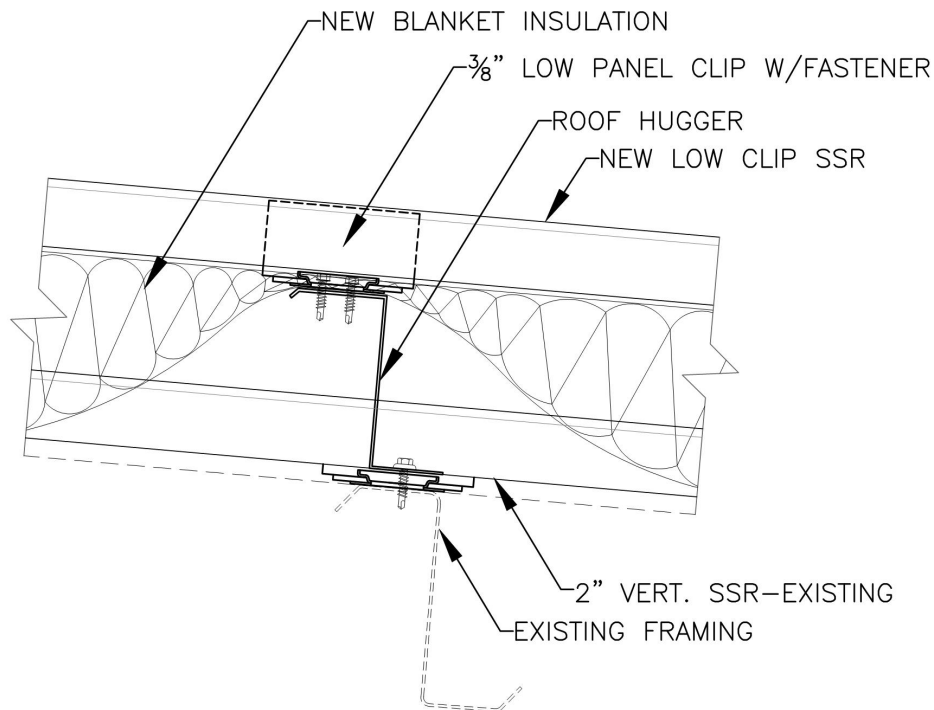

3/8" LOW CLIP SSR OVER SSR
SINGLE BLANKET

System	3/8" Low Clip SSR Over Low Clip 2" Vertical Rib SSR - Single Blanket					
Roof Hugger Web Depth in Inches	Maximum Cavity Depth in Inches	Initial Insulation Thickness in Inches	Estimated R- Value	Estimated U- Value	Thermal Spacer Thickness in Inches	UNFACED Blanket Thickness Combination Used
2.75	3.125	3.50	10.95	0.091	0	3.5" blanket over purlins

Insulated Assemblies (08-2B-S/V)

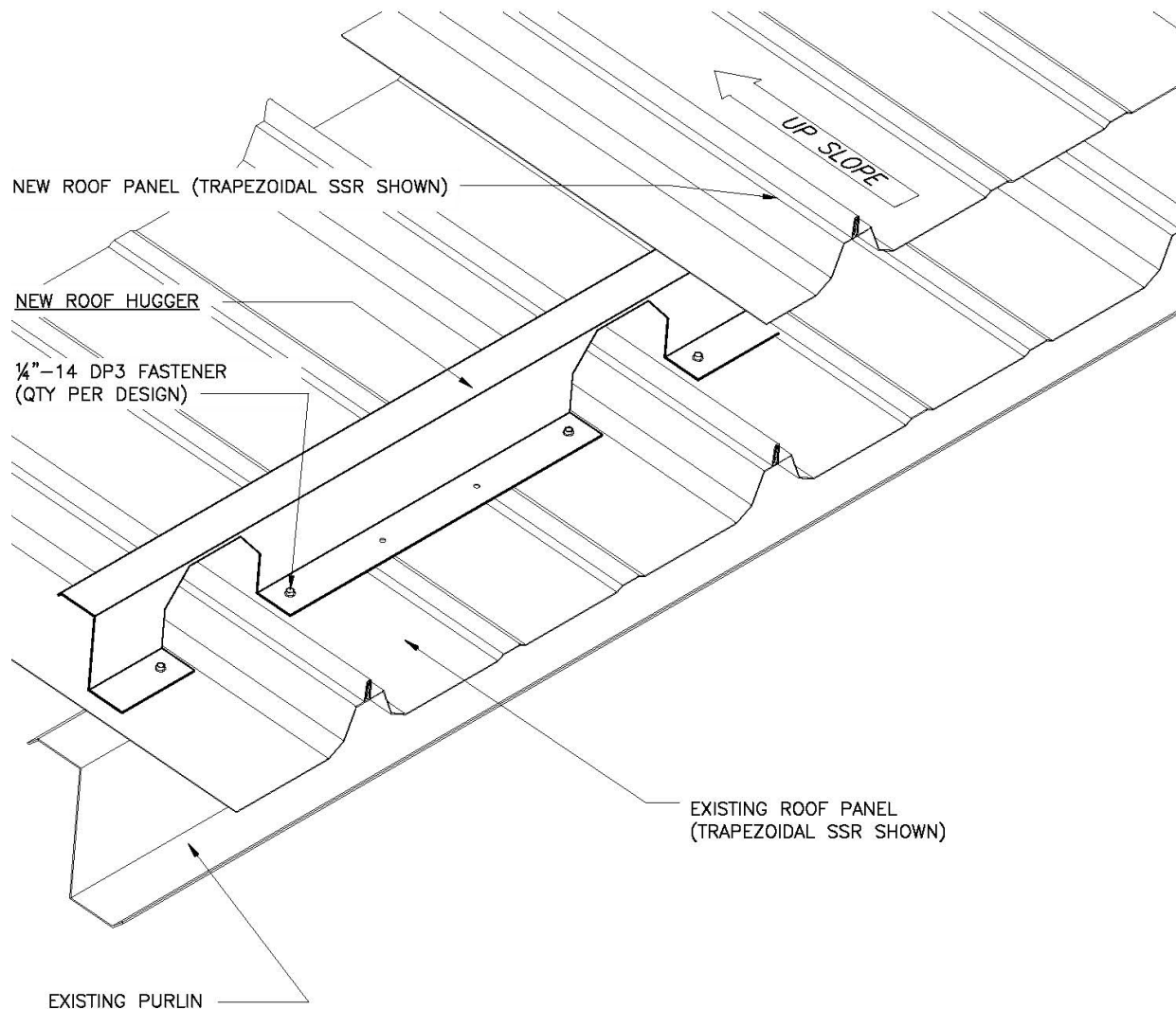
**NOTES:**

1. ALL FASTENERS NOT BY ROOF HUGGER UNLESS NOTED OTHERWISE.
2. FOR EXISTING TRAPEZOIDAL SSR WITH STAND-OFF CLIP AND THERMAL SPACER, REFER TO DETAIL SHEET HA-10-TS0.
3. ALL NEW ROOF SYSTEMS INCLUDING PANEL, FASTENERS, TRIM AND ACCESSORIES TO BE INSTALLED PER THAT MANUFACTURER'S STANDARDS.

Insulated Assemblies (09-1B-S/V)

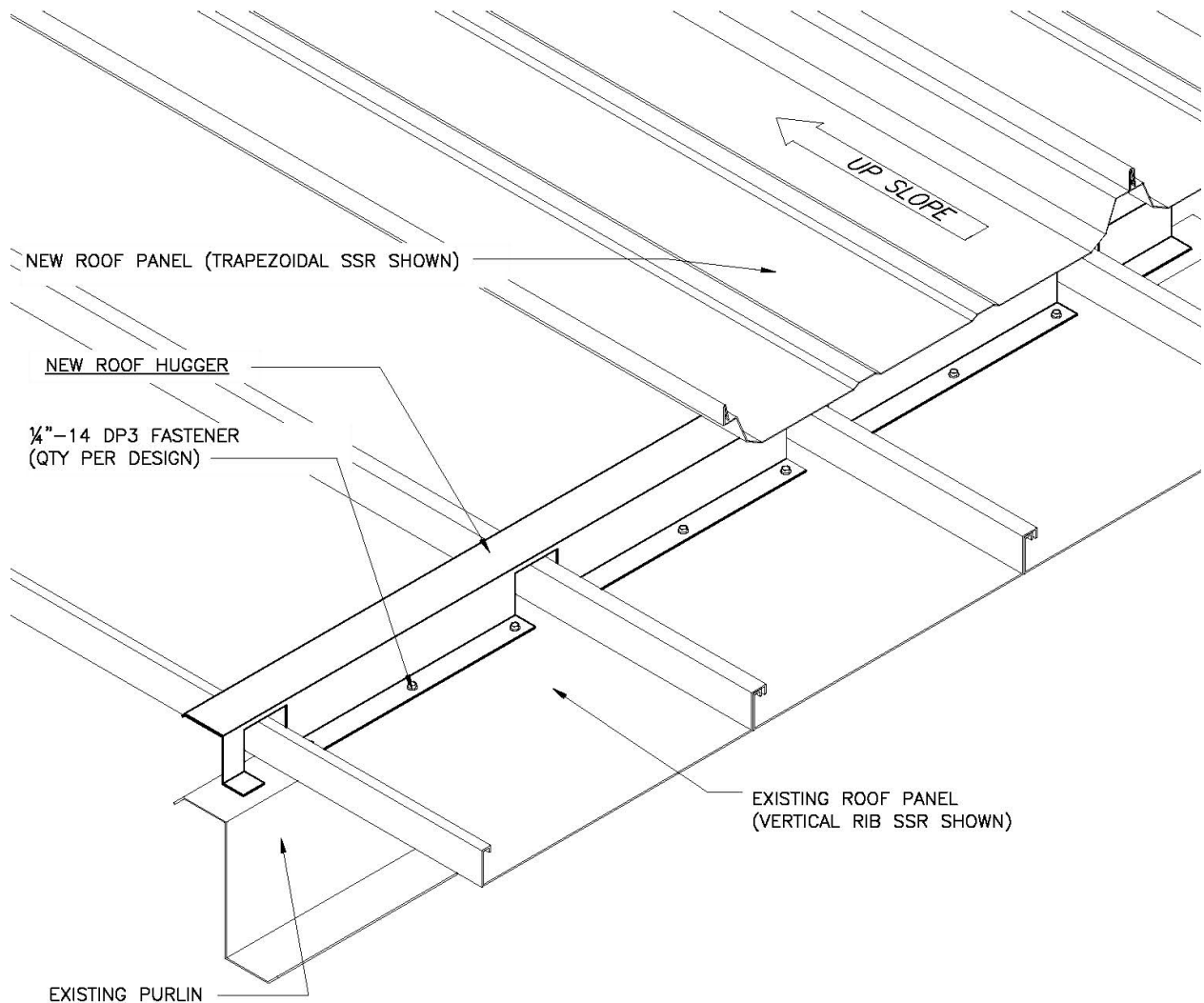
**NOTES:**

1. ALL FASTENERS NOT BY ROOF HUGGER UNLESS NOTED OTHERWISE
2. FOR EXISTING VERTICAL RIB SSR WITH STAND-OFF CLIP AND THERMAL SPACER, REFER TO DETAIL SHEET HA-11-VS0.
3. ALL NEW ROOF SYSTEMS INCLUDING PANEL, FASTENERS, TRIM AND ACCESSORIES TO BE INSTALLED PER THAT MANUFACTURER'S STANDARDS.

Insulated Assemblies (10-2B-S/R)

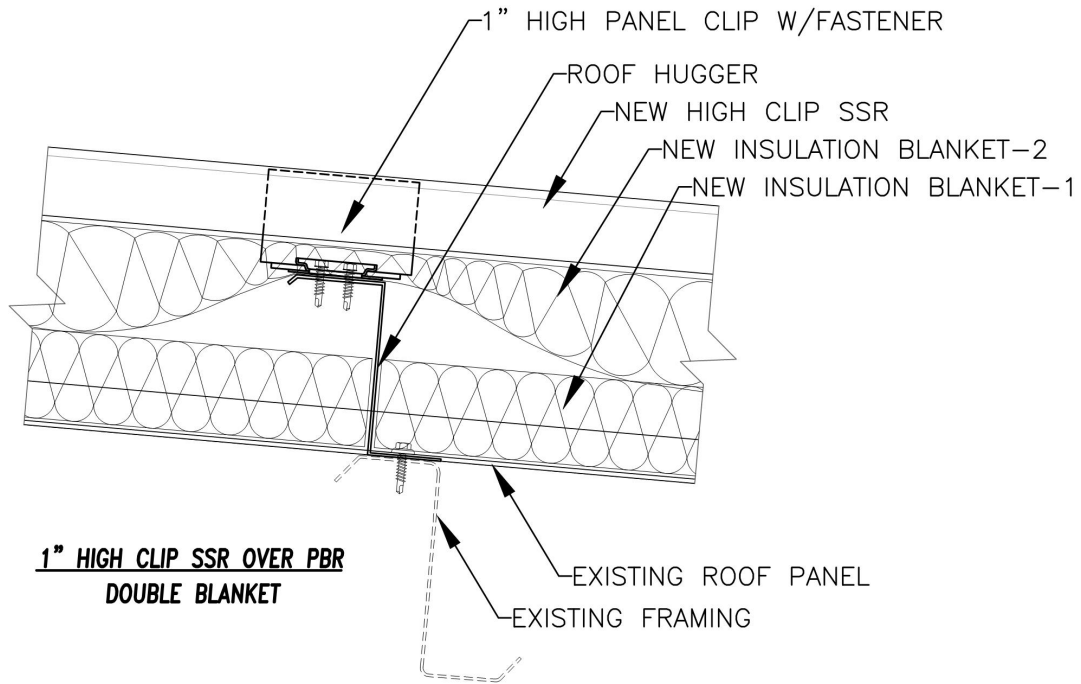

System	1" High Clip SSR Over PBR Panel - Double Blanket					
Roof Hugger Web Depth in Inches	Maximum Cavity Depth in Inches	Initial Insulation Thickness in Inches	Estimated R- Value	Estimated U- Value	Thermal Spacer Thickness in Inches	UNFACED Blanket Thickness Combination Used
3.75	4.750	5.50	17.64	0.057	0.625	2.75" blanket over purlins; 2.75" blanket between purlins
4.50	5.500	6.00	19.89	0.050	0.625	3.0" blanket over purlins; 3.0" blanket between purlins
6.75	7.750	8.00	23.93	0.042	0.625	4.0" blanket over purlins; 4.0" blanket between purlins
Compressed insulation R-Values have been calculated from a published method of the North American Insulation Manufacturers Association™ (NAIMA™).						
Insulation R-Value calculated based on published industry information from NAIMA™, CertainTeed®, Johns Manville® or Owens Corning®.						
Due to variations in installation methods and metal roof rib or seam configurations; calculated values shown herein do not compensate for thermal bridging or thermal loss from existing roof panel rib configuration.						
Calculated R-Values shown herein do not take credit for air film effects or use of vapor barriers within the insulation system.						

Insulated Assemblies (11-1B-S/V)

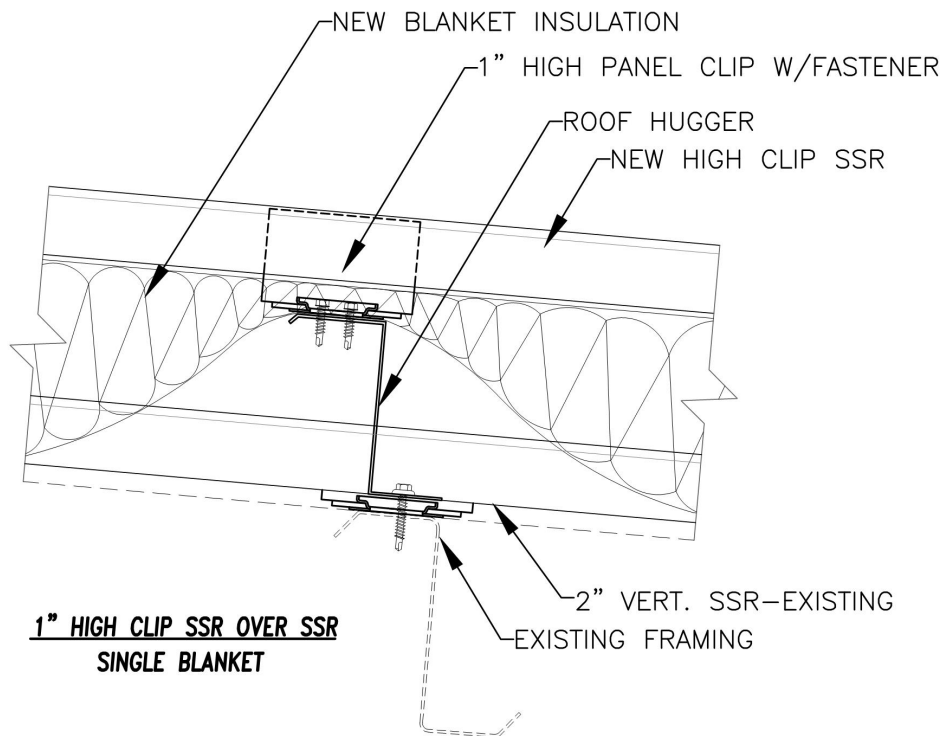

System	1" High Clip SSR Over Low Clip 2" Vertical Rib SSR - Single Blanket					
Roof Hugger Web Depth in Inches	Maximum Cavity Depth in Inches	Initial Insulation Thickness in Inches	Estimated R- Value	Estimated U- Value	Thermal Spacer Thickness in Inches	UNFACED Blanket Thickness Combination Used
2.75	3.750	4.00	11.81	0.085	0.375	4.0" blanket over purlins
Compressed insulation R-Values have been calculated from a published method of the North American Insulation Manufacturers Association™ (NAIMA™).						
Insulation R-Value calculated based on published industry information from NAIMA™, CertainTeed®, Johns Manville® or Owens Corning®.						
Due to variations in installation methods and metal roof rib or seam configurations; calculated values shown herein do not compensate for thermal bridging or thermal loss from existing roof panel rib configuration.						
Calculated R-Values shown herein do not take credit for air film effects or use of vapor barriers within the insulation system.						

Insulated Assemblies (12-2B-S/V)

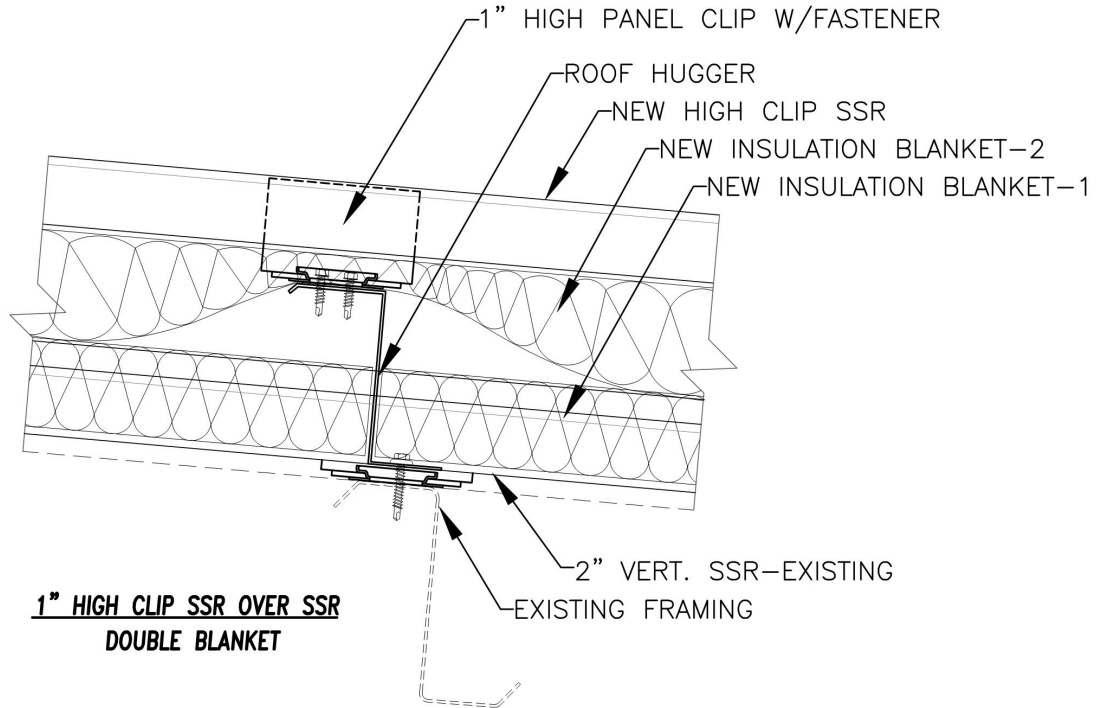

**1" HIGH CLIP SSR OVER SSR
DOUBLE BLANKET**

System	1" High Clip SSR Over Low Clip 2" Vertical Rib SSR - Double Blanket					
Roof Hugger Web Depth in Inches	Maximum Cavity Depth in Inches	Initial Insulation Thickness in Inches	Estimated R- Value	Estimated U- Value	Thermal Spacer Thickness in Inches	UNFACED Blanket Thickness Combination Used
3.75	5.500	5.50	17.64	0.057	0.625	2.75" blanket over purlins; 2.75" blanket between purlins
4.50	6.000	6.00	19.89	0.050	0.625	3.0" blanket over purlins; 3.0" blanket between purlins
6.75	8.000	8.00	23.93	0.042	0.625	4.0" blanket over purlins; 4.0" blanket between purlins
Compressed insulation R-Values have been calculated from a published method of the North American Insulation Manufacturers Association™ (NAIMA™).						
Insulation R-Value calculated based on published industry information from NAIMA™, CertainTeed®, Johns Manville® or Owens Corning®.						
Due to variations in installation methods and metal roof rib or seam configurations; calculated values shown herein do not compensate for thermal bridging or thermal loss from existing roof panel rib configuration.						
Calculated R-Values shown herein do not take credit for air film effects or use of vapor barriers within the insulation system.						

Insulated Assemblies (13-1B-S/T)

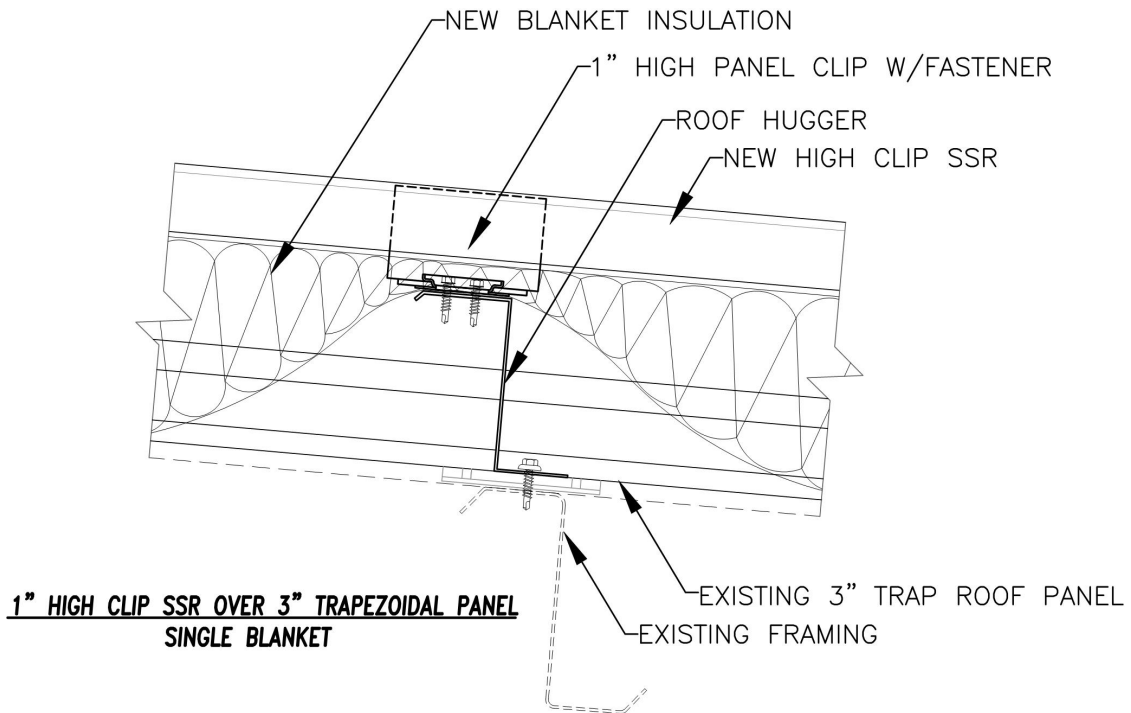

System	1" High Clip SSR Over Low Clip 3" Trap. SSR - Single Blanket					
Roof Hugger Web Depth in Inches	Maximum Cavity Depth in Inches	Initial Insulation Thickness in Inches	Estimated R- Value	Estimated U- Value	Thermal Spacer Thickness in	UNFACED Blanket Thickness Combination Used
4.50	5.500	6.00	17.23	0.058	0.375	6.0" blanket over purlins - no thermal spacer
Compressed insulation R-Values have been calculated from a published method of the North American Insulation Manufacturers Association™ (NAIMA™).						
Insulation R-Value calculated based on published industry information from NAIMA™, CertainTeed®, Johns Manville® or Owens Corning®.						
Due to variations in installation methods and metal roof rib or seam configurations; calculated values shown herein do not compensate for thermal bridging or thermal loss from existing roof panel rib configuration.						
Calculated R-Values shown herein do not take credit for air film effects or use of vapor barriers within the insulation system.						

Insulated Assemblies (14-2B-S/T)

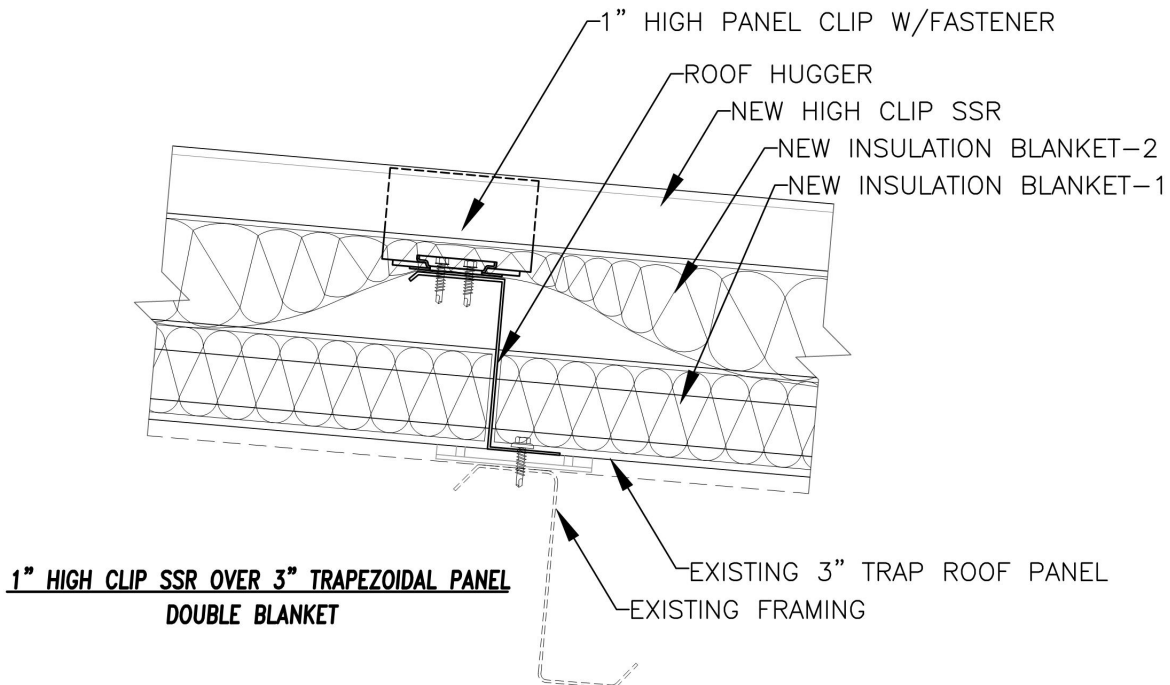

System	1" High Clip SSR Over Low Clip 3" Trap. SSR - Double Blanket					
Roof Hugger Web Depth in Inches	Maximum Cavity Depth in Inches	Initial Insulation Thickness in Inches	Estimated R- Value	Estimated U- Value	Thermal Spacer Thickness in Inches	Blanket Thickness Combination Used
4.50	5.500	5.50	18.87	0.053	0.625	2.75" blanket over purlin; 2.75" blanket between purlins
5.50	6.500	7.00	23.72	0.042	0.375	3.50" blanket over purlin; 3.50" blanket between purlins
6.75	7.750	8.10	24.09	0.042	0.375	4.0" blanket over purlin; 4.0" blanket between purlins
7.50	8.500	8.75	27.14	0.037	0.375	2.75" blanket over purlin; 6.0" blanket between purlins
					0	
Compressed insulation R-Values have been calculated from a published method of the North American Insulation Manufacturers Association™ (NAIMA™).						
Insulation R-Value calculated based on published industry information from NAIMA™, CertainTeed®, Johns Manville® or Owens Corning®.						
Due to variations in installation methods and metal roof rib or seam configurations; calculated values shown herein do not compensate for thermal bridging or thermal loss from existing roof panel rib configuration.						
Calculated R-Values shown herein do not take credit for air film effects or use of vapor barriers within the insulation system.						

Insulated Assemblies (15-2B-T/R)

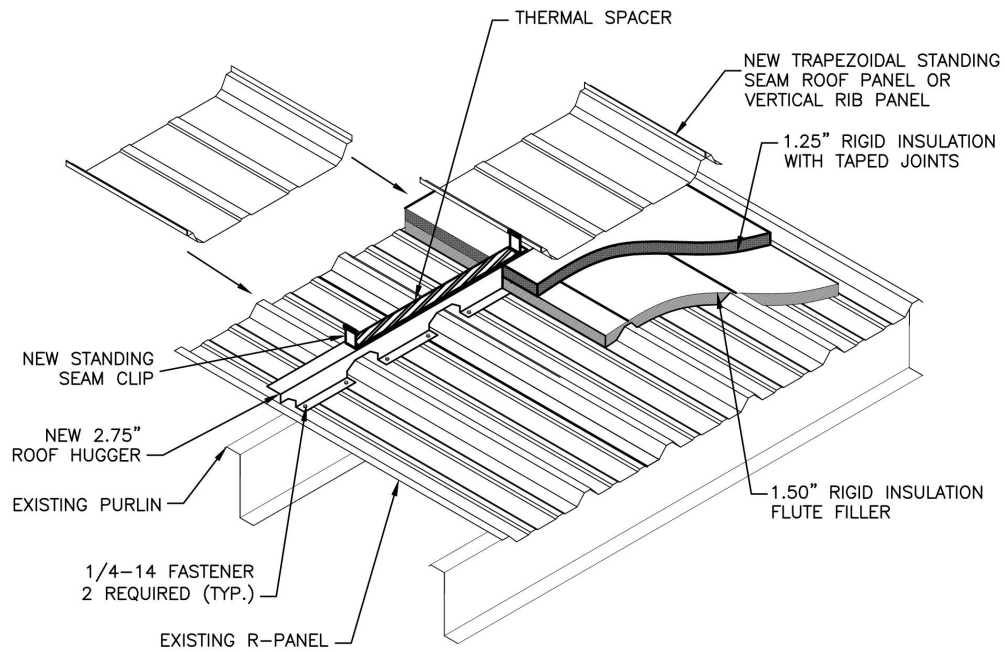

System	2.75 ROOF HUGGER WITH 2 LAYERS OF RIGID INSULATION				
Roof Hugger Web Depth in Inches	Maximum Cavity Depth in Inches	Estimated R-Value	Estimated U-Value	Thermal Spacer Thickness in Inches	Blanket Thickness Combination Used
2.75	2.75	17.45	0.057	0.375	1.50" RIGID FLUTE FILLER INSULATION; 1.25" RIGID INSULATION
ALL FASTENERS, PANELS & INSULATION NOT BY ROOF HUGGER UNLESS NOTED OTHERWISE.					
SEE ROOF HUGGER INSTALLATION INSTRUCTIONS FOR INFORMATION CONCERNING EXISTING FASTENERS BEING REMOVED OR LEFT IN PLACE.					
ALL NEW ROOF SYSTEMS INCLUDING PANEL, FASTENERS, TRIM, AND ACCESSORIES (BY OTHERS) TO BE INSTALLED PER THAT MANUFACTURERS STANDARDS.					
CONSULT PANEL MANUFACTURE ABOUT PANEL RUMBLE IF NO INSULATION INSTALLED ABOVE ROOF HUGGER FRAMING.					

Insulated Assemblies (16-3R-T/R)

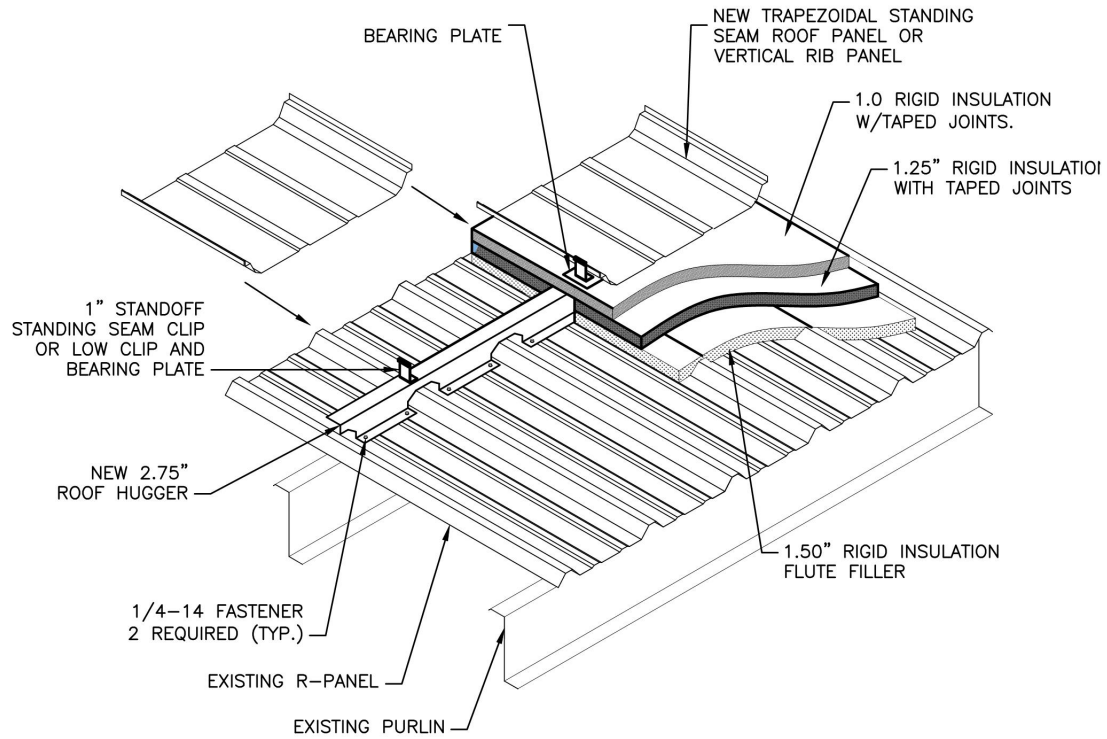

NOTE: ALL RIGID INSULATION VALUES ARE BASED ON POLYISOCYANURATE IN BOARDS WITH ALL TOP LAYER JOINTS AND SEAMS TAPED AND SEALED.

System	2.75" ROOF HUGGER WITH 3 LAYERS OF RIGID INSULATION				
Roof Hugger Web Depth in Inches	Maximum Cavity Depth in Inches	Estimated R- Value	Estimated U- Value	Thermal Spacer Thickness in Inches	Blanket Thickness Combination Used
2.75	3.75	22.8	0.044	0	1.50" FLUTE FILLER RIGID INSULATION; 1.25" RIGID INSULATION; 1.0" RIGID INSULATION
ALL FASTENERS, PANELS & INSULATION NOT BY ROOF HUGGER UNLESS NOTED OTHERWISE.					
SEE ROOF HUGGER INSTALLATION INSTRUCTIONS FOR INFORMATION CONCERNING EXISTING FASTENERS BEING REMOVED OR LEFT IN PLACE.					
ALL NEW ROOF SYSTEMS INCLUDING PANEL, FASTENERS, TRIM, AND ACCESSORIES (BY OTHERS) TO BE INSTALLED PER THAT MANUFACTURERS STANDARDS.					

Insulated Assemblies (17-2R-T/V)

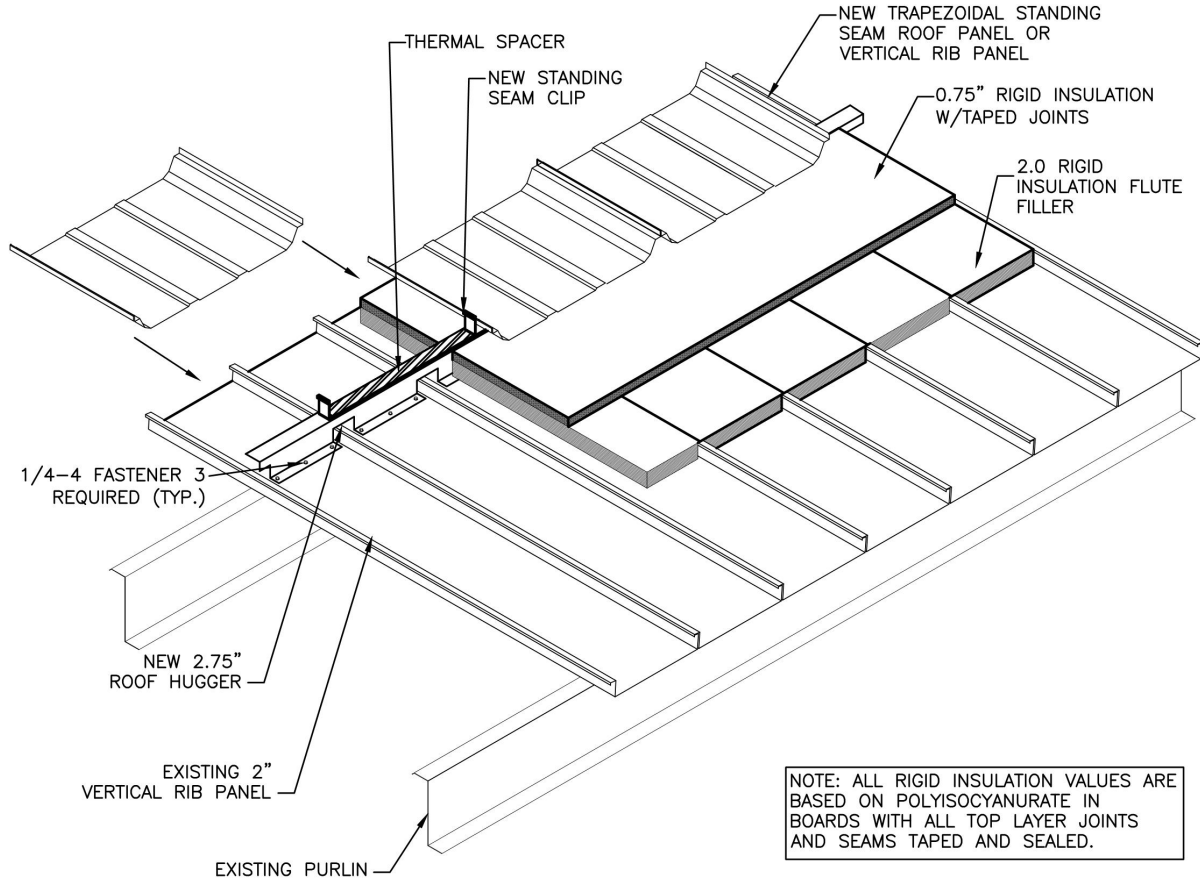

System	2.75" ROOF HUGGER WITH 2 LAYERS OF RIGID INSULATION				
Roof Hugger Web Depth in Inches	Maximum Cavity Depth in Inches	Estimated R- Value	Estimated U- Value	Thermal Spacer Thickness in Inches	Blanket Thickness Combination Used
2.75	2.75	17.45	0.057	0.375	2.00" FLUTE FILLER RIGID INSULATION; 0.75" RIGID INSULATION
ALL FASTENERS, PANELS & INSULATION NOT BY ROOF HUGGER UNLESS NOTED OTHERWISE.					
SEE ROOF HUGGER INSTALLATION INSTRUCTIONS FOR INFORMATION CONCERNING EXISTING FASTENERS BEING REMOVED OR LEFT IN PLACE.					
ALL NEW ROOF SYSTEMS INCLUDING PANEL, FASTENERS, TRIM, AND ACCESSORIES (BY OTHERS) TO BE INSTALLED PER THAT MANUFACTURERS STANDARDS.					
CONSULT PANEL MANUFACTURE ABOUT PANEL RUMBLE IF NO INSULATION INSTALLED ABOVE ROOF HUGGER FRAMING.					

Insulated Assemblies (18-3R-T/V)

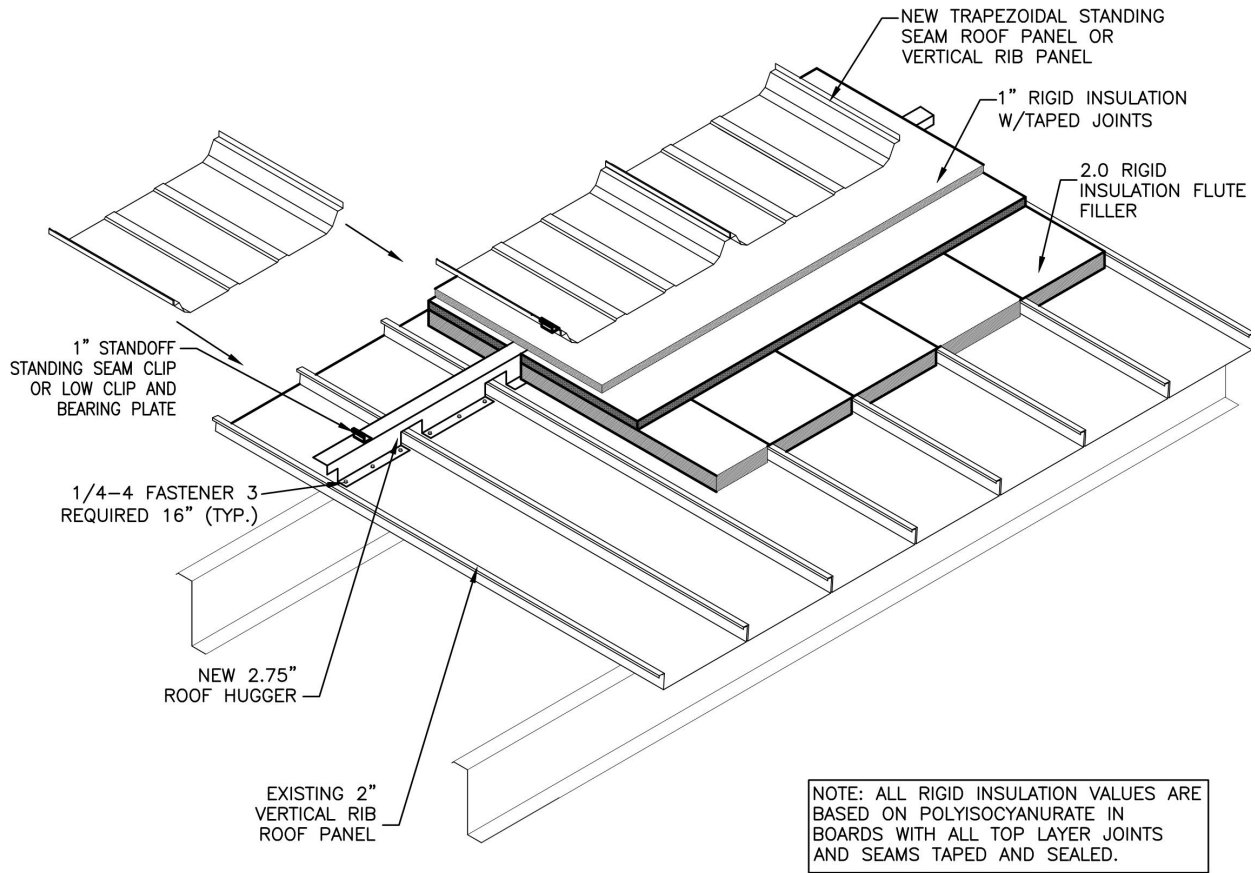

System	2.75" ROOF HUGGER WITH 3 LAYERS OF RIGID INSULATION				
Roof Hugger Web Depth in Inches	Maximum Cavity Depth in Inches	Estimated R-Value	Estimated U-Value	Thermal Spacer Thickness in Inches	Blanket Thickness Combination Used
2.75	3.75	22.8	0.044	0	2.00" FLUTE FILLER RIGID INSULATION; 0.75" RIGID INSULATION; 1.0" RIGID INSULATION
ALL FASTENERS, PANELS & INSULATION NOT BY ROOF HUGGER UNLESS NOTED OTHERWISE.					
SEE ROOF HUGGER INSTALLATION INSTRUCTIONS FOR INFORMATION CONCERNING EXISTING FASTENERS BEING REMOVED OR LEFT IN PLACE.					
ALL NEW ROOF SYSTEMS INCLUDING PANEL, FASTENERS, TRIM, AND ACCESSORIES (BY OTHERS) TO BE INSTALLED PER THAT MANUFACTURERS STANDARDS.					
CONSULT PANEL MANUFACTURE ABOUT PANEL RUMBLE IF NO INSULATION INSTALLED ABOVE ROOF HUGGER FRAMING.					

Insulated Assemblies (19-2R-T/T)

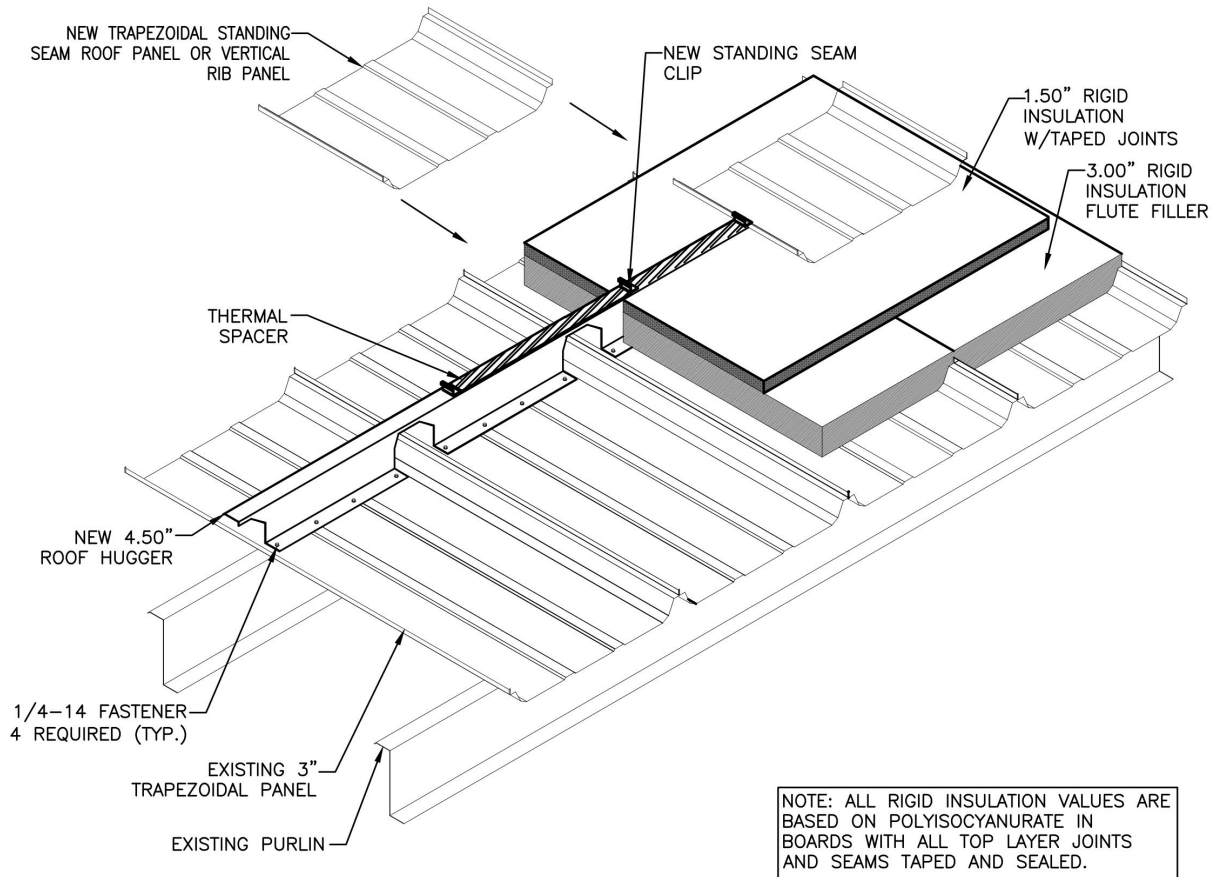

System	4.50" ROOF HUGGER WITH 2 LAYERS OF RIGID INSULATION				
Roof Hugger Web Depth in Inches	Maximum Cavity Depth in Inches	Estimated R-Value	Estimated U-Value	Thermal Spacer Thickness in Inches	Blanket Thickness Combination Used
4.50	4.50	29.66	0.034	0.375	3.00" FLUTE FILLER RIGID INSULATION; 1.50 RIGID INSULATION
ALL FASTENERS, PANELS & INSULATION NOT BY ROOF HUGGER UNLESS NOTED OTHERWISE.					
SEE ROOF HUGGER INSTALLATION INSTRUCTIONS FOR INFORMATION CONCERNING EXISTING FASTENERS BEING REMOVED OR LEFT IN PLACE.					
ALL NEW ROOF SYSTEMS INCLUDING PANEL, FASTENERS, TRIM, AND ACCESSORIES (BY OTHERS) TO BE INSTALLED PER THAT MANUFACTURERS STANDARDS.					
CONSULT PANEL MANUFACTURE ABOUT PANEL RUMBLE IF NO INSULATION INSTALLED ABOVE ROOF HUGGER FRAMING.					
DIFFERENT BASE PANEL & INSULATION LAYER DEPTHS MAY BE SUBSTITUTED IF TOTAL DEPTH IS 4.50"					

Insulated Assemblies (20-3R-T/T)

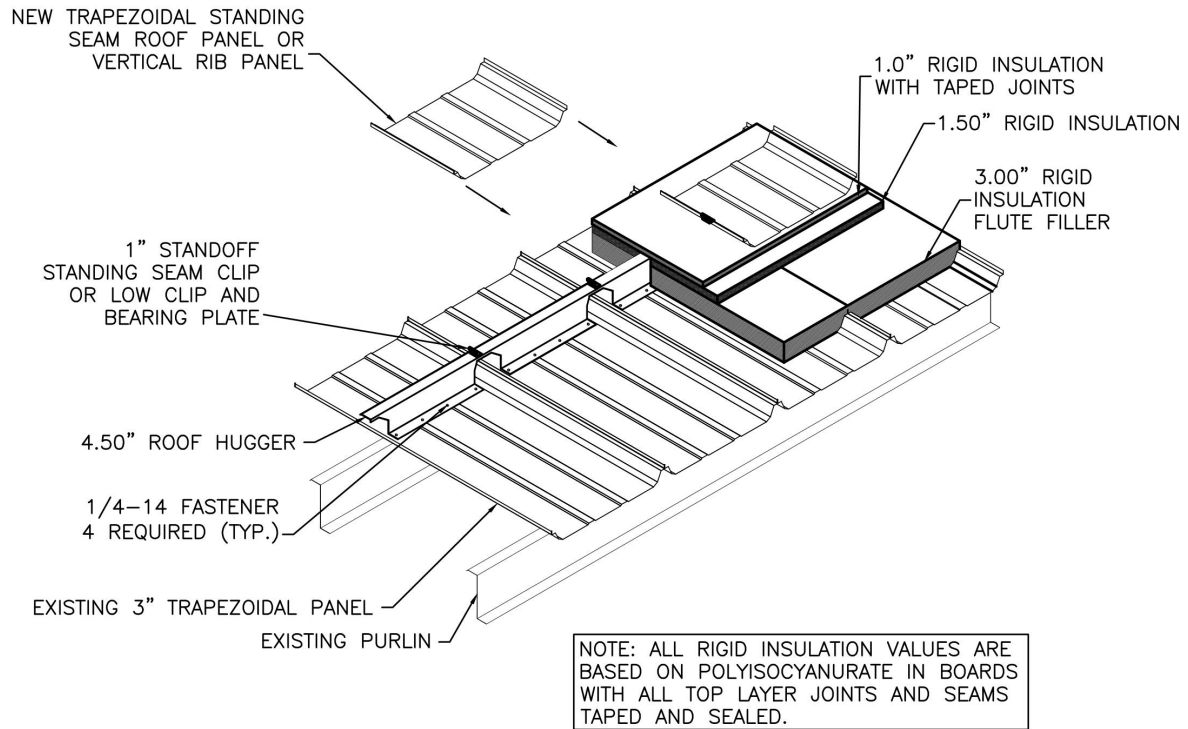

System	4.50" ROOF HUGGER WITH 3 LAYERS OF RIGID INSULATION				Blanket Thickness Combination Used
Roof Hugger Web Depth in Inches	Maximum Cavity Depth in Inches	Estimated R-Value	Estimated U-Value	Thermal Spacer Thickness in Inches	
4.50	4.50	29.66	0.034	0	3.00" FLUTE FILLER RIGID INSULATION; 1.50" RIGID INSULATION; 1.0" RIGID INSULATION
ALL FASTENERS, PANELS & INSULATION NOT BY ROOF HUGGER UNLESS NOTED OTHERWISE.					
SEE ROOF HUGGER INSTALLATION INSTRUCTIONS FOR INFORMATION CONCERNING EXISTING FASTENERS BEING REMOVED OR LEFT IN PLACE.					
ALL NEW ROOF SYSTEMS INCLUDING PANEL, FASTENERS, TRIM, AND ACCESSORIES (BY OTHERS) TO BE INSTALLED PER THAT MANUFACTURERS STANDARDS.					
CONSULT PANEL MANUFACTURE ABOUT PANEL RUMBLE IF NO INSULATION INSTALLED ABOVE ROOF HUGGER FRAMING.					
DIFFERENT BASE PANEL & INSULATION LAYER DEPTHS MAY BE SUBSTITUTED IF TOTAL DEPTH IS 5.50"					



PROVEN SOLUTIONS FOR RE-ROOFING
EXISTING METAL ROOFS

Millions of Square Feet of Roofs Since 1991

Proudly 100% Made in America



A Member Company of



© Copyright 2019 Roof Hugger, LLC

Printed in the USA

Roof Hugger, LLC
P.O. Box 1027
Odessa, FL 33556

P: 1-800-771-1711
F: 1-877-202-2254
www.roofhugger.com